

Subwoofer

BRAVIA Theatre Sub 9/ BRAVIA Theatre Sub 8

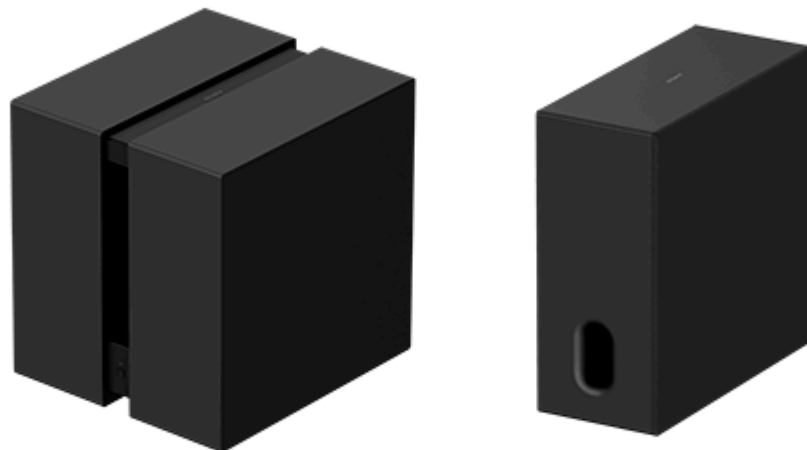

Model: YY2102C/ YY2103C

This Help Guide explains the installation and connection of BRAVIA Theatre Sub 9 and BRAVIA Theatre Sub 8. In the Help Guide, “the subwoofer” refers to either or both.

The connection procedure of this subwoofer varies depending on the connected device.

Be sure to select the link (blue text) of the device to which you want to connect from the list below, then follow the guidance displayed on the page to connect the subwoofer.

## **Connecting to a main audio device such as a sound bar that supports the “Sony | BRAVIA Connect” app**

[Connecting to a Main Audio Device that Supports the “Sony | BRAVIA Connect” App](#)

## **Connecting to one of the following main audio devices**

[Connecting to an HT-A7000, HT-A5000, or HT-A3000 Sound Bar](#)

[Connecting to an HT-A9](#)

[Connecting to an STR-AN1000, STR-AZ7000ES, STR-AZ5000ES, STR-AZ3000ES, STR-AZ1000ES, or TA-AN1000 AV Receiver/Amplifier](#)

## About devices that are compatible with the subwoofer

This subwoofer is a product that works only with specific models.

The model names of devices that are compatible with the subwoofer can be found at the following URL.

### Main audio devices (sound bar/home theater system/AV receiver/AV amplifier) that are compatible with the subwoofer

<https://www.sony.net/comp-home/>

#### Hint

- You can connect two of these subwoofers to a main audio device, such as a sound bar, which supports dual subwoofer. (Both subwoofers must have the same model name.)
- Check the product specifications on Sony's product information website to confirm if the main audio device supports dual subwoofer.
- The subwoofer may not connect to the main audio device until the software of the subwoofer or the main audio device is updated.

SA-SW9/ SA-SW8

#### [Devices That Are Connected to the Subwoofer](#)

##### Checking the Package Contents

[Package Contents \(BRAVIA Theatre Sub 9\)](#)

[Package Contents \(BRAVIA Theatre Sub 8\)](#)

##### Parts and Controls

[BRAVIA Theatre Sub 9](#)

[BRAVIA Theatre Sub 8](#)

[About the Indicator](#)

##### Installation

[Installing on the Floor or Shelf](#)

##### Connecting

[Connecting to a Main Audio Device such as a Sound Bar that Supports the "Sony\\_| BRAVIA Connect" App](#)

[Connecting to an HT-A7000, HT-A5000, or HT-A3000 Sound Bar](#)

[Connecting to an HT-A9](#)

[Connecting to an STR-AN1000, STR-AZ7000ES, STR-AZ5000ES, STR-AZ3000ES, STR-AZ1000ES, or TA-AN1000 AV Receiver/Amplifier](#)

##### Troubleshooting

[Troubleshooting](#)

---

[Customer Support Website](#)

---

[Resetting the Subwoofer](#)

[Specifications](#)

Additional Information

[Trademarks](#)

---

[Licenses](#)

---

[Notes on Use](#)

Subwoofer  
BRAVIA Theatre Sub 9/ BRAVIA Theatre Sub 8

## Devices That Are Connected to the Subwoofer

The subwoofer is a product that works only with specific models.  
The model names of devices that are compatible with the subwoofer can be found at the following URL.

### Main audio devices that are compatible with the subwoofer

<https://www.sony.net/comp-home/>

#### Hint

- You can connect two of these subwoofers to a main audio device, such as a sound bar, which supports dual subwoofer. (Both subwoofers must have the same model name.)
- Check the product specifications on Sony's product information website to confirm if the main audio device supports dual subwoofer.
- The subwoofer may not connect to the main audio device until the software of the subwoofer or the main audio device is updated.

### Devices that connected to BRAVIA Theatre Sub 9

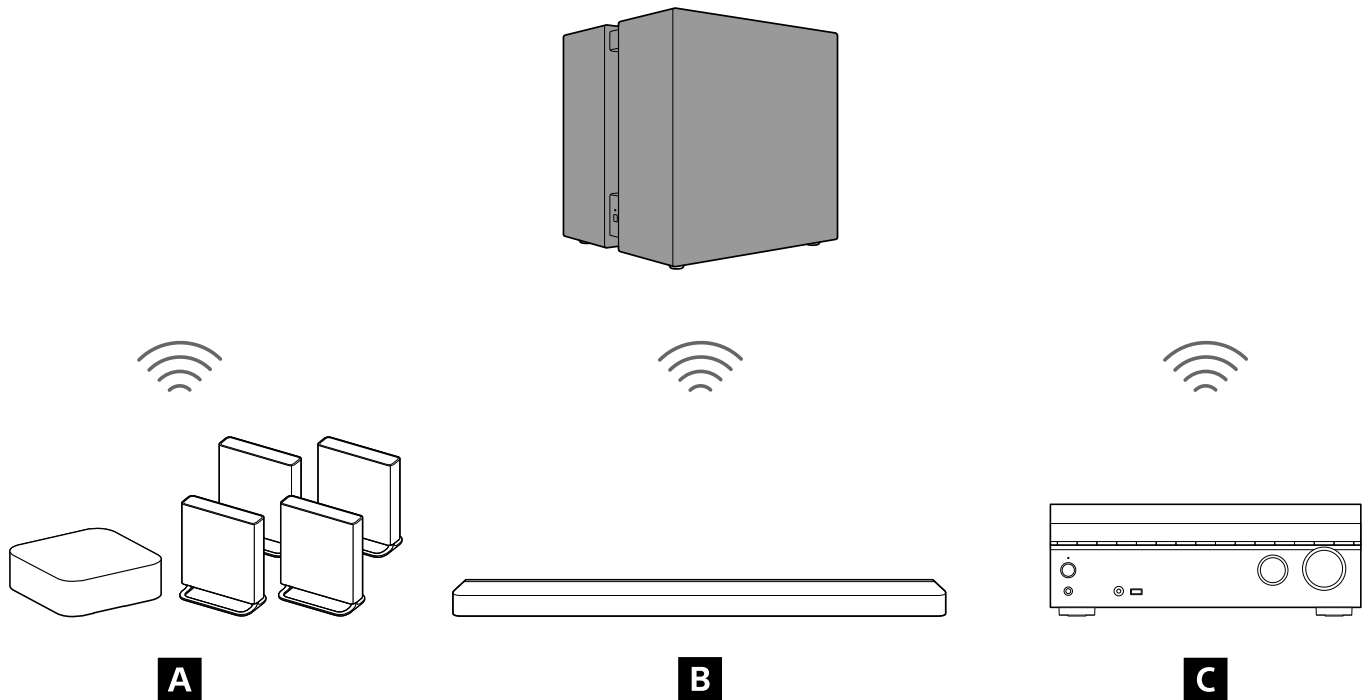

- A** Home Theatre System
- B** Sound Bar
- C** Multi-channel AV receiver/multi-channel AV amplifier

### Devices that connected to BRAVIA Theatre Sub 8

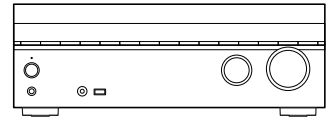
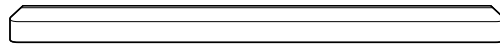
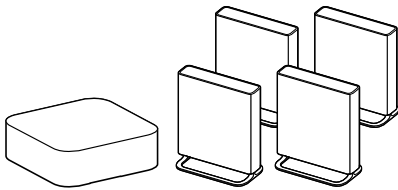
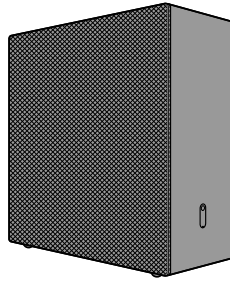

**A**

**B**

**C**

- A** Home Theatre System
- B** Sound Bar
- C** Multi-channel AV receiver/multi-channel AV amplifier

TP1002215087

Subwoofer

BRAVIA Theatre Sub 9/ BRAVIA Theatre Sub 8

## Package Contents (BRAVIA Theatre Sub 9)

---

If any of the supplied items are missing, please consult your nearest Sony dealer. The numbers indicate the supplied quantity.

The availability and quantity of the supplied items vary depending on the country/region of purchase.

Refer to the Reference Guide included with your product to confirm the availability and quantity of the supplied items.

- Subwoofer (1)

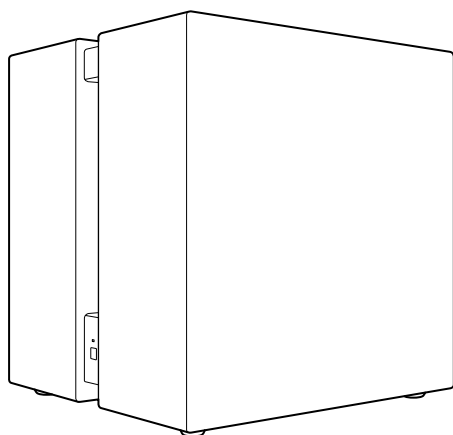

- AC power cord (mains lead) (1 or 2)

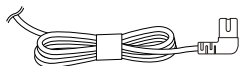

- Documents (1 set)

### Parts included only in some countries/regions

- AC plug adaptor (1)

TP1002102710

Subwoofer

BRAVIA Theatre Sub 9/ BRAVIA Theatre Sub 8

## Package Contents (BRAVIA Theatre Sub 8)

---

If any of the supplied items are missing, please consult your nearest Sony dealer. The numbers indicate the supplied quantity.

The availability and quantity of the supplied items vary depending on the country/region of purchase.

Refer to the Reference Guide included with your product to confirm the availability and quantity of the supplied items.

- Subwoofer (1)

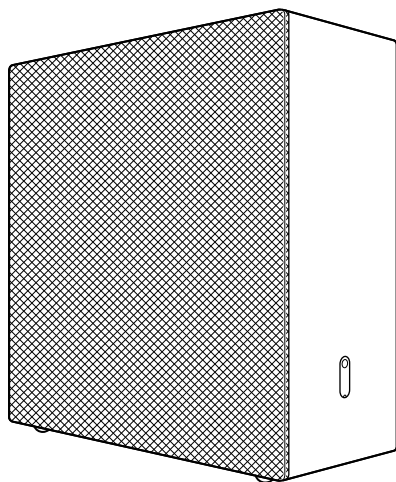

- AC power cord (mains lead) (1 or 2)

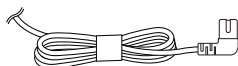

- Documents (1 set)

### Parts included only in some countries/regions

- AC plug adaptor (1)

TP1002102711

Subwoofer

BRAVIA Theatre Sub 9/ BRAVIA Theatre Sub 8

## BRAVIA Theatre Sub 9

---

### Left side, front

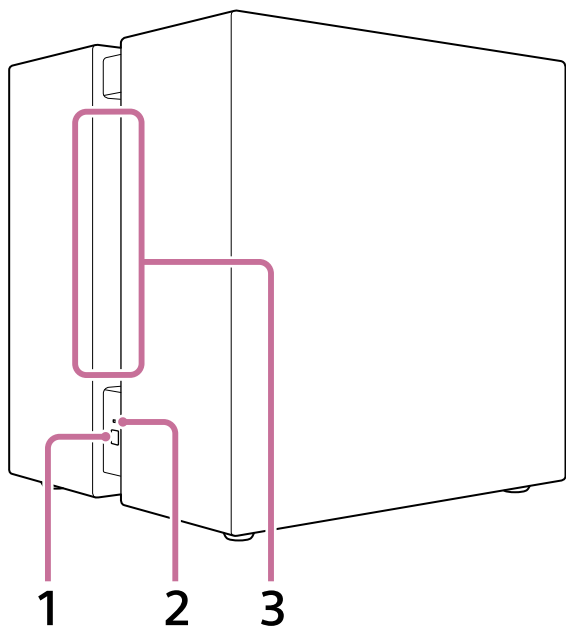

#### 1. **LINK** (It is on the lower part of the left side.)

- **Press:** Press to connect the subwoofer. Follow the connection procedure to operate.
- **Press and hold for 2 seconds until the notification sound plays:** Turns off the subwoofer.
- **Press and hold for 10 seconds until the second notification sound plays:** Resets the subwoofer.

#### 2. **Power indicator** (It is on the lower part of the left side.)

Indicates the subwoofer status by lighting or flashing in 3 colors (white/blue/red).

#### 3. **Opening**

Sound is output from this opening that runs from the left side to the right side of the subwoofer.

### Bottom

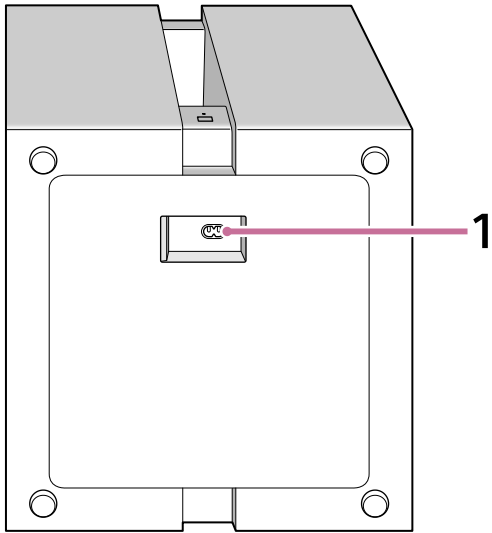

## 1. AC inlet

### Note

- When carrying the subwoofer, have 2 people hold the bottom.

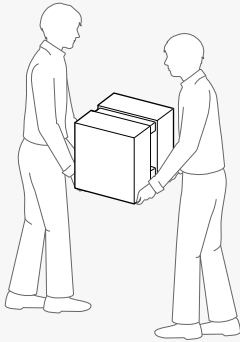

### Hint

- The AC inlet is on the bottom of the subwoofer. When connecting the AC power cord (mains lead), there is no problem laying the subwoofer down. Handle the subwoofer carefully when laying it down.
- Route the AC power cord (mains lead) connected to the subwoofer in the direction you want.

---

## Related Topic

- [About the Indicator](#)
- [Resetting the Subwoofer](#)

TP1002102712

Subwoofer  
BRAVIA Theatre Sub 9/ BRAVIA Theatre Sub 8

## BRAVIA Theatre Sub 8

### Front, right side

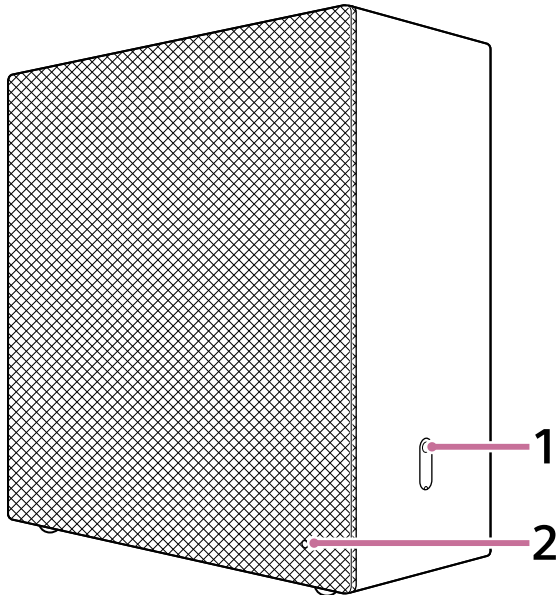

1. **LINK** (It is on the lower part of the right side.)

- **Press:** Press to connect the subwoofer. Follow the connection procedure to operate.
- **Press and hold for 2 seconds until the notification sound plays:** Turns off the subwoofer.
- **Press and hold for 10 seconds until the second notification sound plays:** Resets the subwoofer.

2. **Power indicator** (It is on the lower right of the front covered with cloth.)  
Indicates the subwoofer status by lighting or flashing in 3 colors (white/blue/red).

### Rear, left side

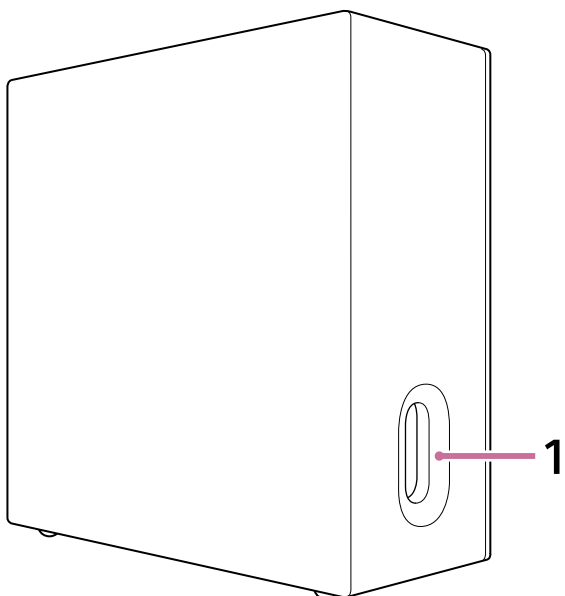

1. **Opening** (It is on the lower part of the left side.)

## Bottom

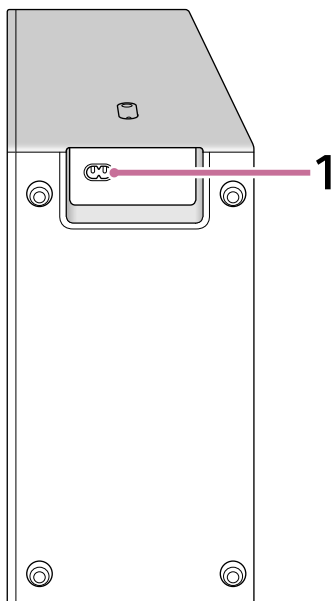

### 1. AC inlet

#### Hint

- The AC inlet is on the bottom of the subwoofer. When connecting the AC power cord (mains lead), there is no problem laying the subwoofer down. Handle the subwoofer carefully when laying it down.
- Route the AC power cord (mains lead) connected to the subwoofer in the direction you want.

TP1002102713

Subwoofer  
BRAVIA Theatre Sub 9/ BRAVIA Theatre Sub 8

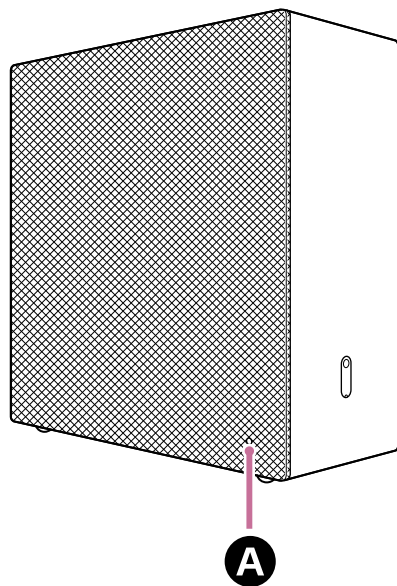
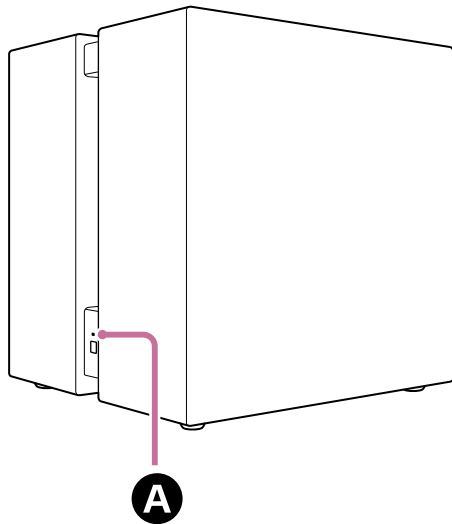

## About the Indicator

Both BRAVIA Theatre Sub 9 and BRAVIA Theatre Sub 8 have an indicator to indicate the product status.





### **A** Power indicator

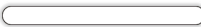

#### **Power condition**

-  .....  ..... (Flashing slowly in white)  
Power is turning on.
-  (Lit up in red)  
The subwoofer is in standby mode.
- ..... (Turned off)  
The subwoofer is turned off.

#### **Connecting status with the compatible device**

-  (Lit up in white)  
The subwoofer is connected to a compatible device.
-  (Flashing slowly in white)  
The subwoofer is waiting for a connection from the compatible device.
-  (Flashing twice repeatedly in white)  
The subwoofer is waiting for a manual connection from the compatible device.

## Special conditions

-  (Flashing in white/blue alternately)  
Software updating/resetting, etc. is in progress.
-  (Flashing in white)  
Wireless function is off. Operate LINK to turn on the wireless function.
-  (Flashing in red)  
An abnormality or error has been detected. Follow the steps in “[Troubleshooting](#).”

---

### Related Topic

- [Troubleshooting](#)
- [Resetting the Subwoofer](#)

TP1002102714

Subwoofer  
BRAVIA Theatre Sub 9/ BRAVIA Theatre Sub 8

## Installing on the Floor or Shelf

---

This section explains examples of installing the subwoofer.

### How to install

The following installation diagram is an example.

#### Example of installation in combination with the sound bar

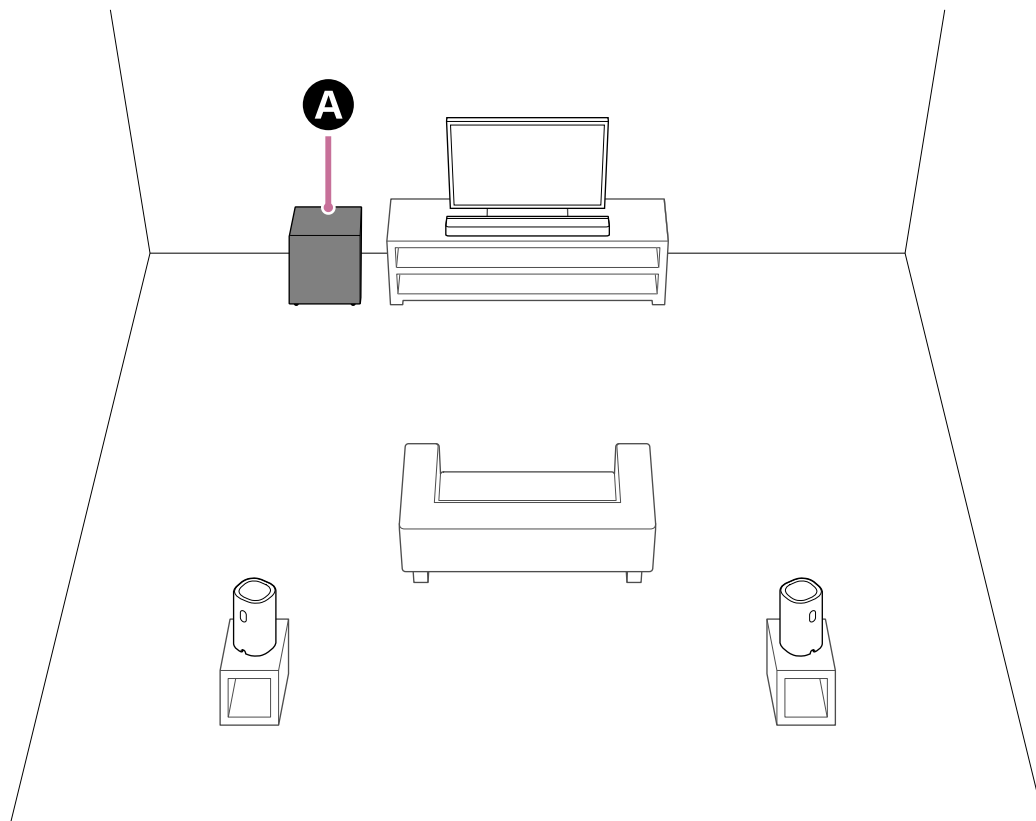

**A** BRAVIA Theatre Sub 9 or BRAVIA Theatre Sub 8

#### Example of installation in combination with the home theater system

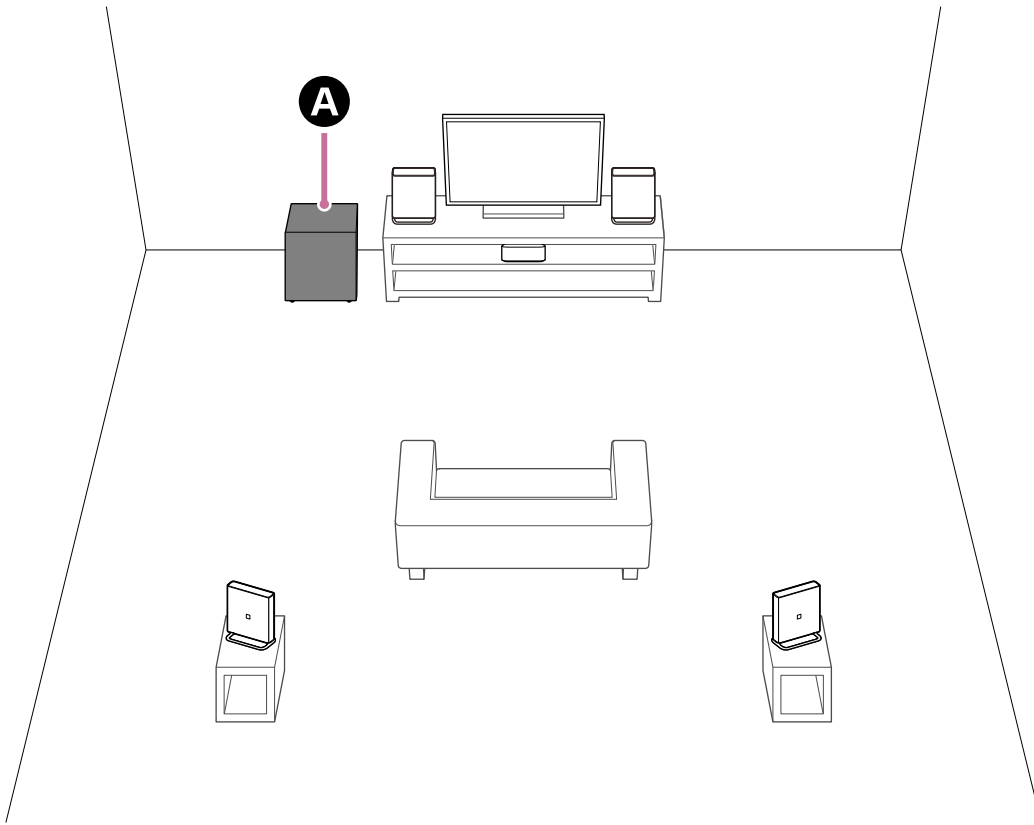

**A** BRAVIA Theatre Sub 9 or BRAVIA Theatre Sub 8

**Example of installation with the multi-channel AV receiver/multi-channel AV amplifier**

This is an installation example for a 5.1 channel speaker system.

When used with a 5.1 channel speaker system, the front and center speakers and rear speaker are required in addition to the subwoofer.

Refer to the Help Guide of the multi-channel AV receiver/multi-channel AV amplifier for information on speaker placement according to speaker system configuration.

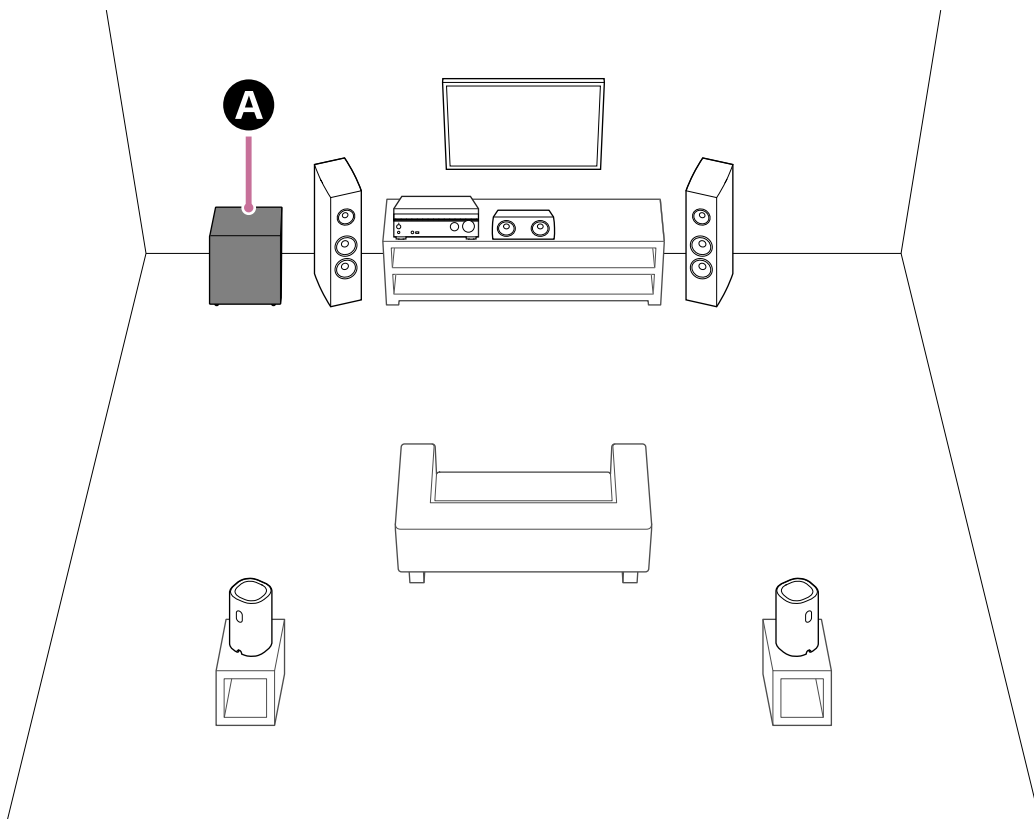

## **Installing the subwoofer**

The sound output from the subwoofer is omni-directional, so the subwoofer can be positioned as desired.

- Do not place the subwoofer lying down.
- BRAVIA Theatre Sub 9 outputs sound from the opening of both sides. Place the subwoofer to leave either of the openings open.
- BRAVIA Theatre Sub 8 outputs sound from the cloth-covered side and the opening on the side. When the face that outputs sound is close to a wall or furniture, place the subwoofer apart from them at more than 5 cm (2 in).

TP1002215088

5-071-616-11(1) Copyright 2026 Sony Corporation

Subwoofer

BRAVIA Theatre Sub 9/ BRAVIA Theatre Sub 8

## Connecting to a Main Audio Device such as a Sound Bar that Supports the “Sony | BRAVIA Connect” App

Be sure to launch or install the “Sony | BRAVIA Connect” app from the link in step 1 on this page. The guidance for installing and connecting the subwoofer starts on the app.

If you have installed the app already, be sure to update the app to the latest version before beginning the steps below. After updating the app, proceed to step 1 without launching the app.

[Go to the website where you can update the app to the latest version.](#)

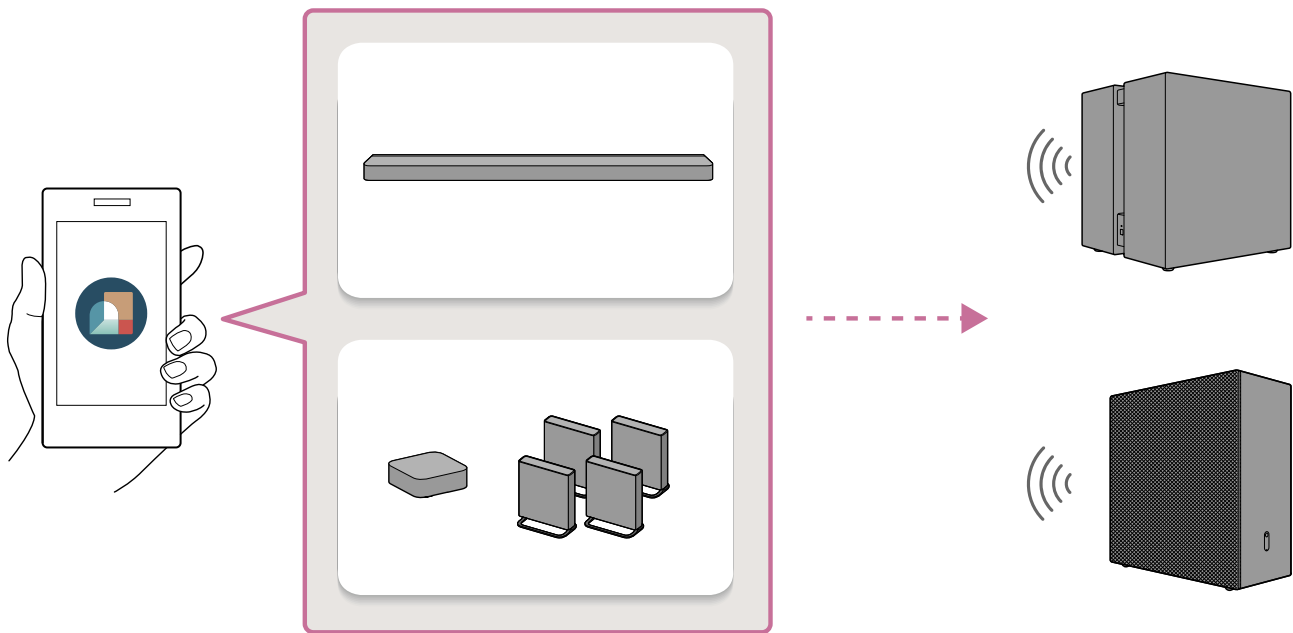

**1** Tap the following link (blue text), then start the setup of the subwoofer with the app.

### Note

- Your IP address and device identifier information will be shared with Sony corporation's service providers when you install or launch the app.

### Connecting BRAVIA Theatre Sub 9

[Start the setup of BRAVIA Theatre Sub 9 with the app.](#)

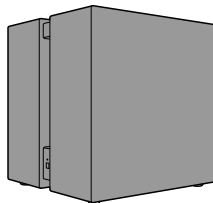

### Connecting BRAVIA Theatre Sub 8

[Start the setup of BRAVIA Theatre Sub 8 with the app.](#)

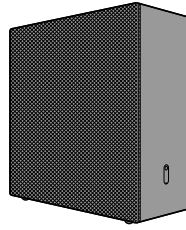

#### Hint

- Perform the same procedure when connecting optional Sony wireless speakers other than BRAVIA Theatre Sub 9 or BRAVIA Theatre Sub 8 together. Follow the guidance on the app screen, and you will see the connection guidance for each speaker.
- You may not be able to launch or install the app by tapping the link above or scanning the QR code below. In this case, tap the link corresponding to your smartphone on the displayed web page to launch or install the app. Then, proceed to step 2.

If you are viewing this Help Guide on a computer, scan the QR code below with your smartphone.

### Connecting BRAVIA Theatre Sub 9



### Connecting BRAVIA Theatre Sub 8



## 2 Follow the guidance on the app screen to continue setting up the subwoofer.

First, select the device to which you want to connect the subwoofer.

If a notification of a software update for your main audio device (such as a sound bar) is displayed, follow the guidance on the app screen. Similarly, follow the guidance on the app screen for installation and connection of the subwoofer.

#### Hint

- If the initial setup of your main audio device (such as a sound bar) has not been completed, you will need to set up your main audio device before connecting the subwoofer. Follow the guidance on the app screen.
- If the initial setup of the main audio device (such as a sound bar) has been completed, select the main audio device to which you want to connect the subwoofer on the app screen, then connect the subwoofer by tapping [Settings] - [Wireless

---

---

## Related Topic

- [Installing on the Floor or Shelf](#)

TP1002102716

Subwoofer

BRAVIA Theatre Sub 9/ BRAVIA Theatre Sub 8

## Connecting to an HT-A7000, HT-A5000, or HT-A3000 Sound Bar

HT-A7000, HT-A5000, and HT-A3000 sound bars do not support the “Sony | BRAVIA Connect” app. Display the setting screen of the sound bar on the TV screen to operate the connection procedure.

The sound bar may not connect to the subwoofer until the software of the sound bar is updated.

### 1 Turn on the sound bar to which the subwoofer is connected as well as the TV, and switch the TV input to the sound bar.

It takes a while for the sound bar to start up. The operation can be performed when [HELLO] or [PLEASE WAIT] disappears from the display panel.

### 2 Update the software of the sound bar to the latest version.

The procedure for updating the software depends on whether the initial setup of the sound bar has been completed.

#### Note

- The Help Guide for the sound bar may suggest updating the software with the optional speakers connected to the sound bar, but update the software of the sound bar without connecting the subwoofer.

### If the initial setup of the sound bar has already been completed (if you are already using it)

1. Press HOME on the remote control supplied with the sound bar and select [Setup] - [Advanced Settings] - [Software Update] - [Network Update] on the home menu displayed on the TV screen.
2. Follow the on-screen instructions on the TV screen to update the software.

### If the initial setup of the sound bar has not been completed (e.g., immediately after purchasing the sound bar)

1. Press HOME on the remote control supplied with the sound bar and follow the on-screen instructions that appear on the TV screen to begin the initial setup.
2. Even if the [Checking Wireless Speaker Connection] screen appears, select [Next] without connecting the subwoofer to the sound bar.
3. Connect the sound bar to the Internet via the [Easy Network Setup] screen and follow the on-screen instructions to continue the initial setup.
4. When the screen confirming the execution of the software update appears, select [Yes] to execute the software update.
5. Even if the [Sound Field Optimization] screen appears, proceed without executing it.
6. If the [Easy Sound Setup] screen appears, select [Cancel].
7. Continue the initial setup until the home menu appears.

#### Hint

- You can also update the sound bar software to the latest version by downloading the latest software from Sony's support page to a USB memory.  
For details, refer to the Help Guide for the sound bar.

**3** Connect the AC power cord (mains lead) to the AC inlet on the subwoofer, then connect to the AC outlet (mains).

When connecting the AC power cord (mains lead), there is no problem laying the subwoofer down. Handle the subwoofer carefully when laying it down.

For information on installation, see “Related Topic” listed at the bottom of this page.

**BRAVIA Theatre Sub 9**

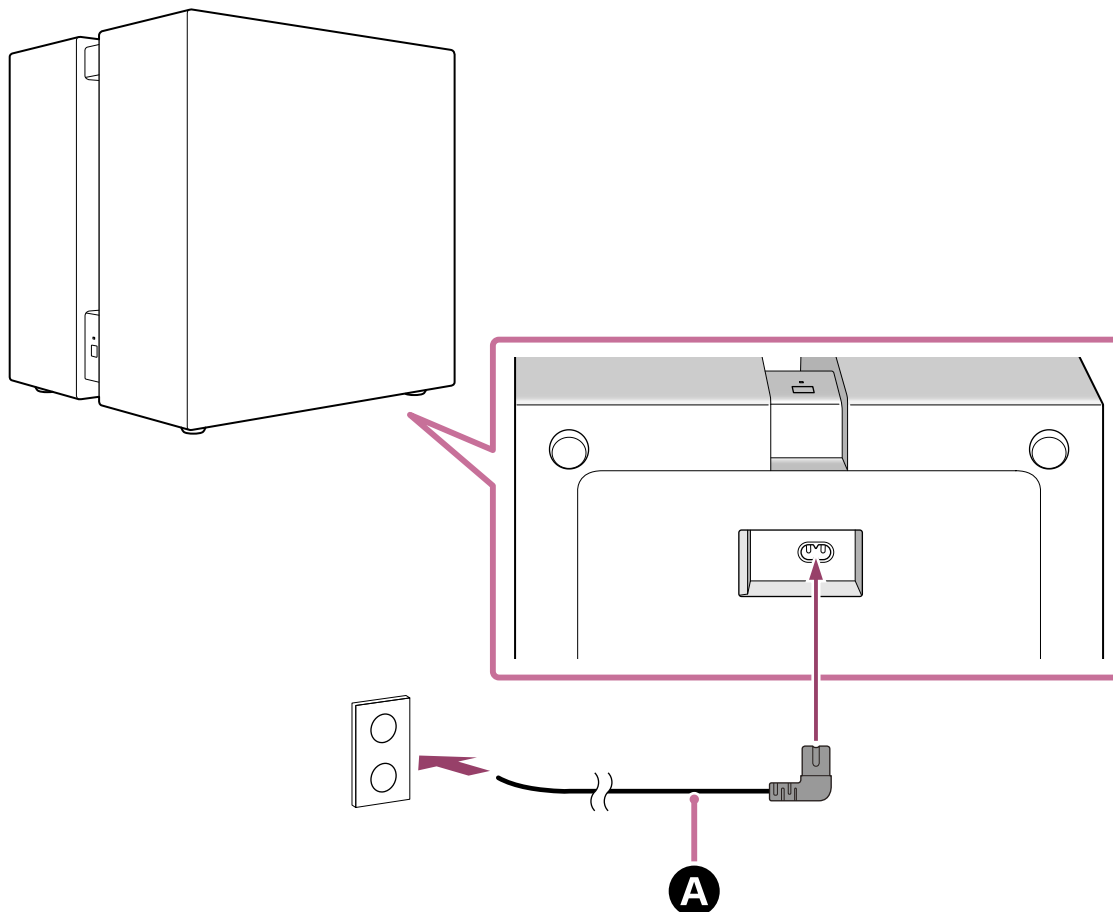

**BRAVIA Theatre Sub 8**

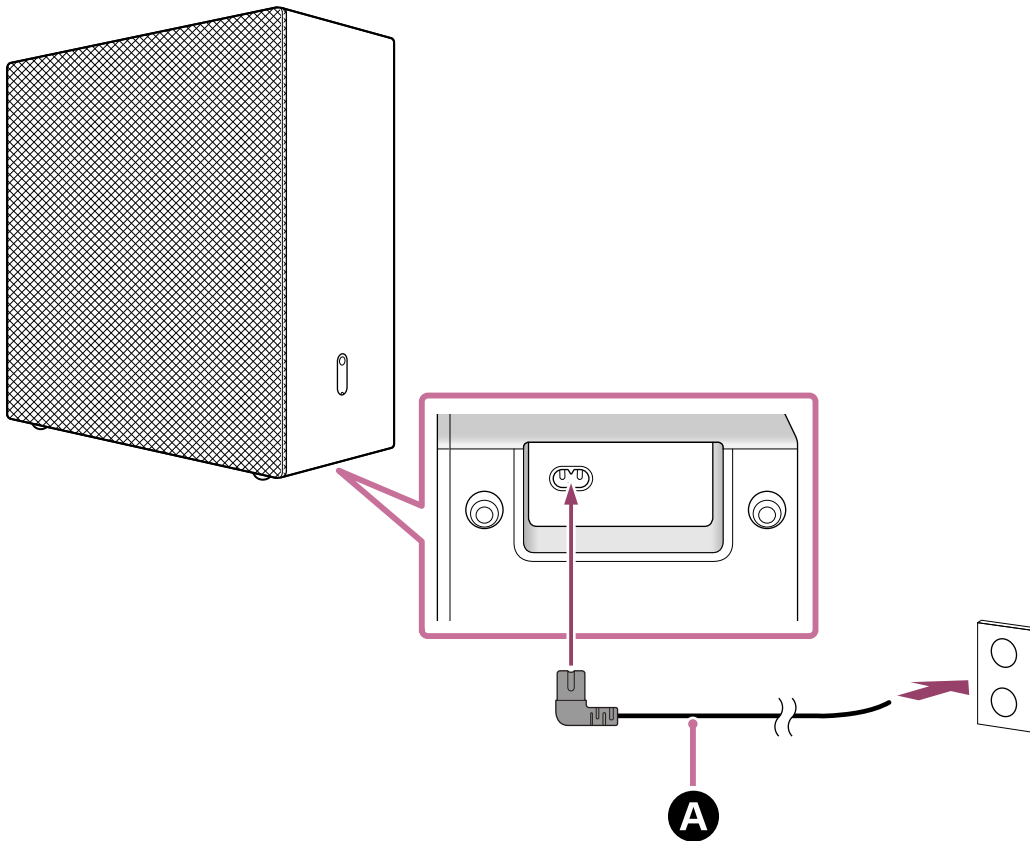

**A** AC power cord (mains lead) (supplied)

**4** Check that the power indicator on the subwoofer lights in white.

When the power indicator lights in white, the connection between the subwoofer and the sound bar is complete.

**Note**

- The Help Guide for the sound bar may state that the power indicator lights in green, but the power indicator on the subwoofer is white.

**BRAVIA Theatre Sub 9**

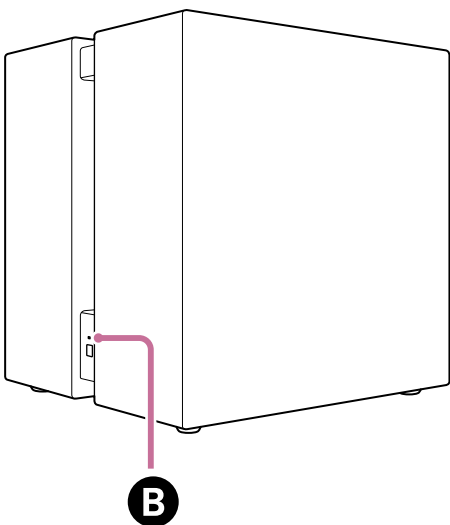

**BRAVIA Theatre Sub 8**

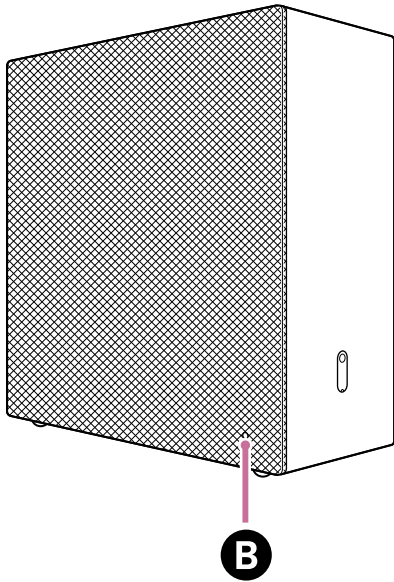

**B** Power indicator

**If the subwoofer does not automatically connect to the sound bar or if you replace another subwoofer that is already connected to the sound bar with this subwoofer**

The subwoofer must be connected manually to the sound bar.

For instructions on how to connect manually, refer to “Connecting the Optional Speaker with the Manual Connection” in the Help Guide for the sound bar. You can connect the subwoofer to the sound bar with the same operation.

**Note**

- If the optional rear speaker has been connected already, it must also be connected manually again.

- 5** Press **HOME** on the remote control supplied with the sound bar and perform sound field optimization by selecting **[Setup] - [Advanced Settings] - [Speaker Settings] - [Sound Field Optimization]** in the home menu.

---

**Related Topic**

- [Installing on the Floor or Shelf](#)

TP1002102717

Subwoofer

BRAVIA Theatre Sub 9/ BRAVIA Theatre Sub 8

## Connecting to an HT-A9

HT-A9 does not support the “Sony | BRAVIA Connect” app. Display the setting screen of the HT-A9 on the TV screen to operate the connection procedure.

The HT-A9 may not connect to the subwoofer until the software of the HT-A9 is updated.

### 1 Turn on the HT-A9 as well as the TV, and switch the TV input to the HT-A9.

It takes a while for the HT-A9 to start up. The operation can be performed when [HELLO] or [PLEASE WAIT] disappears from the display panel.

### 2 Update the software of the HT-A9 to the latest version.

The procedure for updating the software depends on whether the initial setup of the HT-A9 has been completed.

#### Note

- The Help Guide for the HT-A9 may suggest updating the software with the optional speakers connected to the HT-A9, but update the software of the HT-A9 without connecting the subwoofer.

#### If the initial setup of the HT-A9 has already been completed (if you are already using it)

1. Press HOME on the remote control supplied with the HT-A9 and select [Setup] - [Advanced Settings] - [Software Update] - [Network Update] on the home menu displayed on the TV screen.
2. Follow the on-screen instructions on the TV screen to update the software.

#### If the initial setup of the HT-A9 has not been completed (e.g., immediately after purchasing the HT-A9)

1. Press HOME on the remote control supplied with the HT-A9 and follow the on-screen instructions that appear on the TV screen to begin the initial setup.
2. When the [Easy Network Setup] screen appears, connect the HT-A9 to the Internet.
3. When the screen confirming the execution of the software update appears, select [Yes] to execute the software update.
4. Follow the instructions on the initial setup screen to complete all settings.

#### Hint

- You can also update the HT-A9 software to the latest version by downloading the latest software from Sony's support page to a USB memory.  
For details, refer to the Help Guide for the HT-A9.

### 3 Connect the AC power cord (mains lead) to the AC inlet on the subwoofer, then connect to the AC outlet (mains).

When connecting the AC power cord (mains lead), there is no problem laying the subwoofer down. Handle the subwoofer carefully when laying it down.

For information on installation, see “Related Topic” listed at the bottom of this page.

## BRAVIA Theatre Sub 9

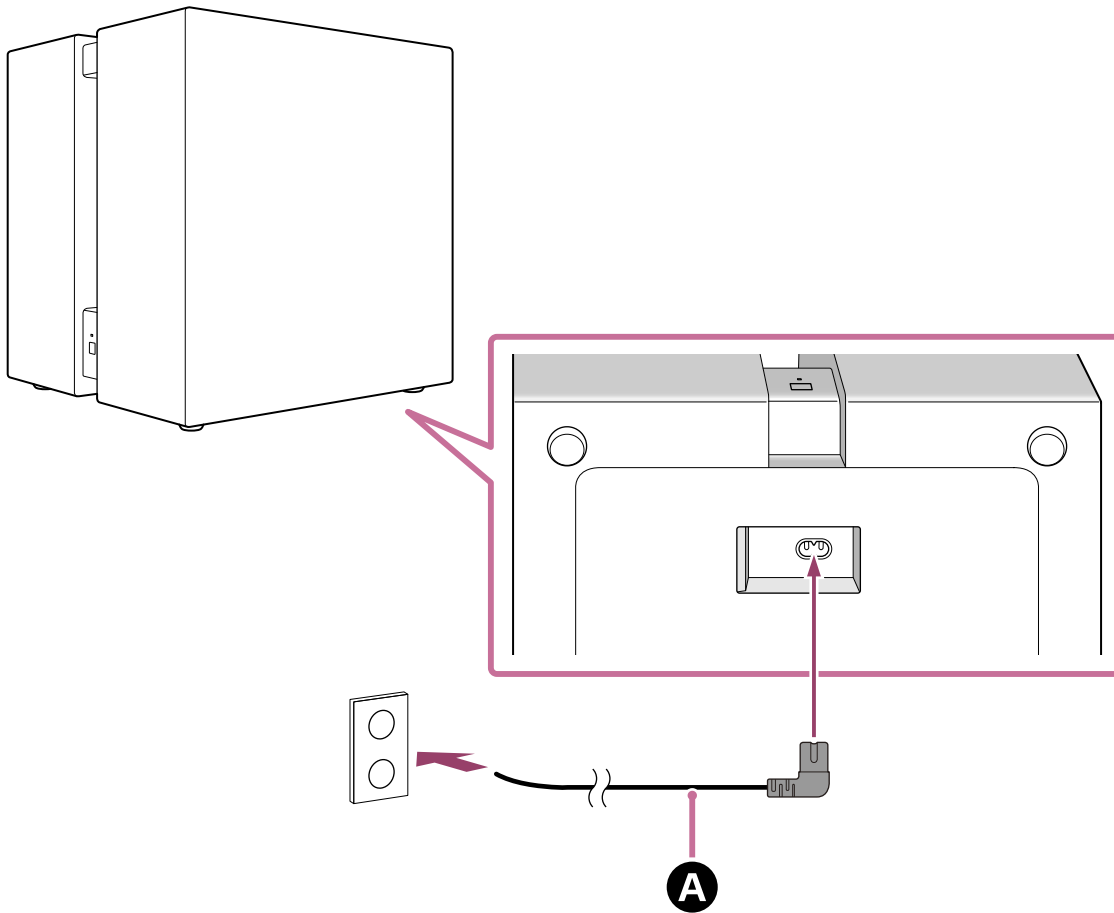

## BRAVIA Theatre Sub 8

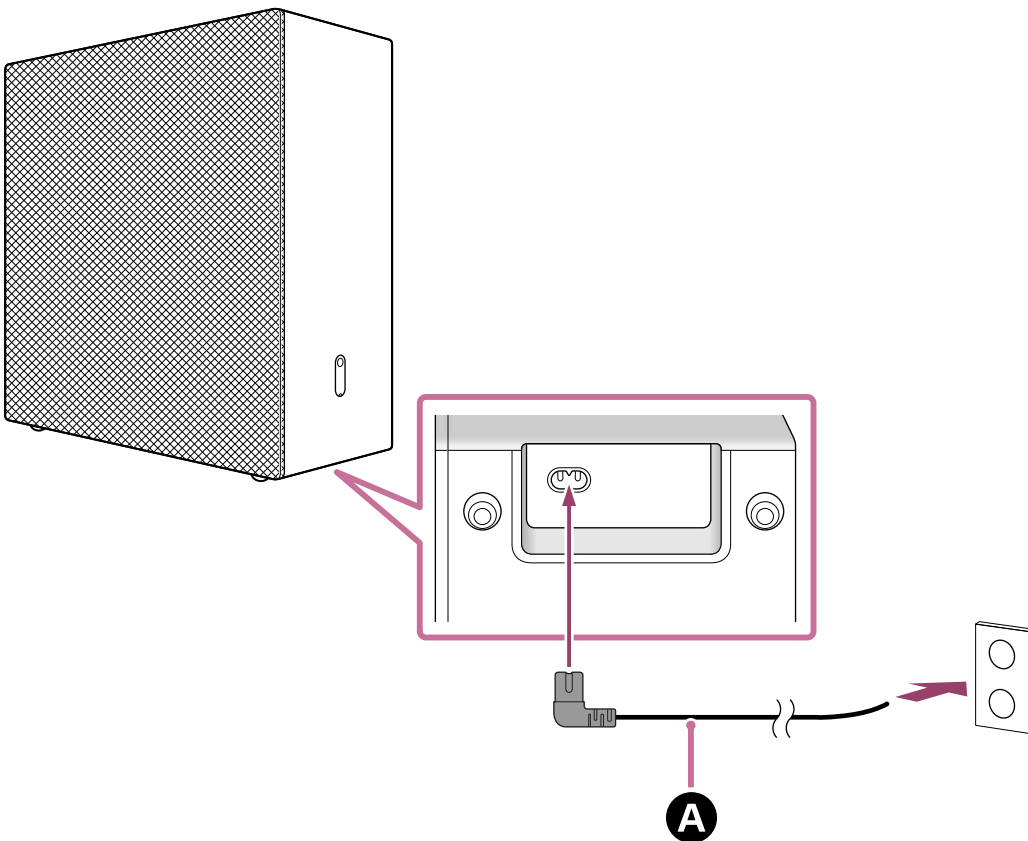

**A** AC power cord (mains lead) (supplied)

Check that the power indicator on the subwoofer lights in white.

When the power indicator lights in white, the connection between the subwoofer and the HT-A9 is complete.

**Note**

- The Help Guide for the main audio device (such as the HT-A9) may state that the power indicator lights in green, but the power indicator on the subwoofer is white.

**BRAVIA Theatre Sub 9**

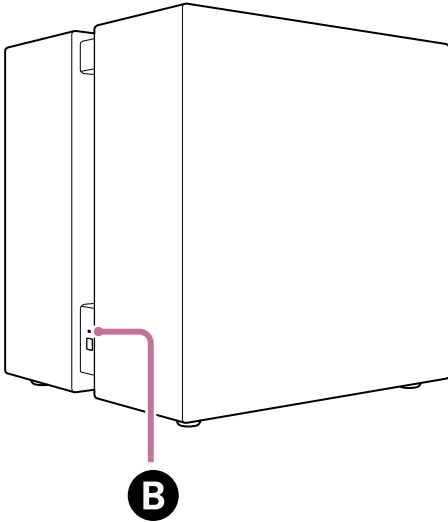

**BRAVIA Theatre Sub 8**

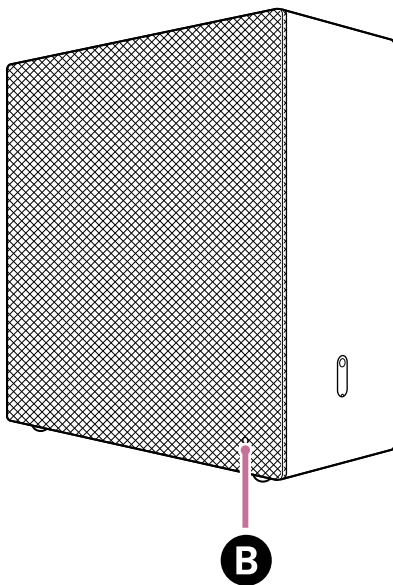

**B** Power indicator

**If the subwoofer does not automatically connect to the HT-A9 or if you replace another subwoofer that is already connected to the HT-A9 with this subwoofer**

The subwoofer must be connected manually to the HT-A9.

For instructions on how to connect manually, refer to “If the Speakers Are not Connected Correctly” in the Help Guide for the HT-A9. You can connect the subwoofer to the HT-A9 with the same operation.

**Note**

- If the optional rear speaker has been connected already, it must also be connected manually again.

- 5 Press **HOME** on the remote control supplied with the HT-A9 and perform sound field optimization by selecting **[Setup] - [Advanced Settings] - [Speaker Settings] - [Sound Field Optimization]** in the home menu.

---

#### Related Topic

- [Installing on the Floor or Shelf](#)

TP1002102718

5-071-616-11(1) Copyright 2026 Sony Corporation

Subwoofer

BRAVIA Theatre Sub 9/ BRAVIA Theatre Sub 8

## Connecting to an STR-AN1000, STR-AZ7000ES, STR-AZ5000ES, STR-AZ3000ES, STR-AZ1000ES, or TA-AN1000 AV Receiver/Amplifier

STR-AN1000, STR-AZ7000ES, STR-AZ5000ES, STR-AZ3000ES, STR-AZ1000ES, and TA-AN1000 AV receivers/amplifiers do not support the “Sony | BRAVIA Connect” app. Display the setting screen of the AV receiver/amplifier on the TV screen to operate the connection procedure.

The AV receiver/amplifier may not connect to the subwoofer until the software of the AV receiver/amplifier is updated.

### 1 Turn on the AV receiver/amplifier to which the subwoofer is connected as well as the TV, and switch the TV input to the AV receiver/amplifier.

It takes a while for the AV receiver/amplifier to start up. The operation can be performed when [HELLO] or [PLEASE WAIT] disappears from the display panel.

### 2 Update the software of the AV receiver/amplifier to the latest version.

The procedure for updating the software depends on whether the initial setup of the AV receiver/amplifier has been completed.

#### Note

- The Help Guide for the AV receiver/amplifier may suggest updating the software with the optional speakers connected to the AV receiver/amplifier, but update the software of the AV receiver/amplifier without connecting the subwoofer.

### If the initial setup of the AV receiver/amplifier has already been completed (if you are already using it)

1. Press HOME on the remote control supplied with the AV receiver/amplifier and select [Setup] - [Software Update] - [Network Update] on the home menu displayed on the TV screen.
2. Follow the on-screen instructions on the TV screen to update the software.

### If the initial setup of the AV receiver/amplifier has not been completed (e.g., immediately after purchasing the AV receiver/amplifier)

1. Press HOME on the remote control supplied with the AV receiver/amplifier.
2. Follow the instructions on the TV screen to set the language to be displayed on the screen, select [Internet Settings] on the displayed screen, follow the on-screen instructions to complete the connection of the AV receiver/amplifier to the Internet, then select [OK].  
Do not proceed to the next setting.
3. Press HOME on the remote control supplied with the AV receiver/amplifier and select [Setup] - [Software Update] - [Network Update] on the home menu displayed on the TV screen.
4. Check the software update progress in the display panel of the AV receiver/amplifier.  
The progress rate is displayed in percentage (“XXX%”).  
When the update is completed, [COMPLETED] appears in the display panel and the AV receiver/amplifier restarts automatically.

#### Hint

- You can also update the AV receiver/amplifier software to the latest version by downloading the latest software from Sony's support page to a USB memory.  
For details, refer to the Help Guide for the AV receiver/amplifier.

**3 Connect the AC power cord (mains lead) to the AC inlet on the subwoofer, then connect to the AC outlet (mains).**

When connecting the AC power cord (mains lead), there is no problem laying the subwoofer down. Handle the subwoofer carefully when laying it down.

For information on installation, see “Related Topic” listed at the bottom of this page.

**BRAVIA Theatre Sub 9**

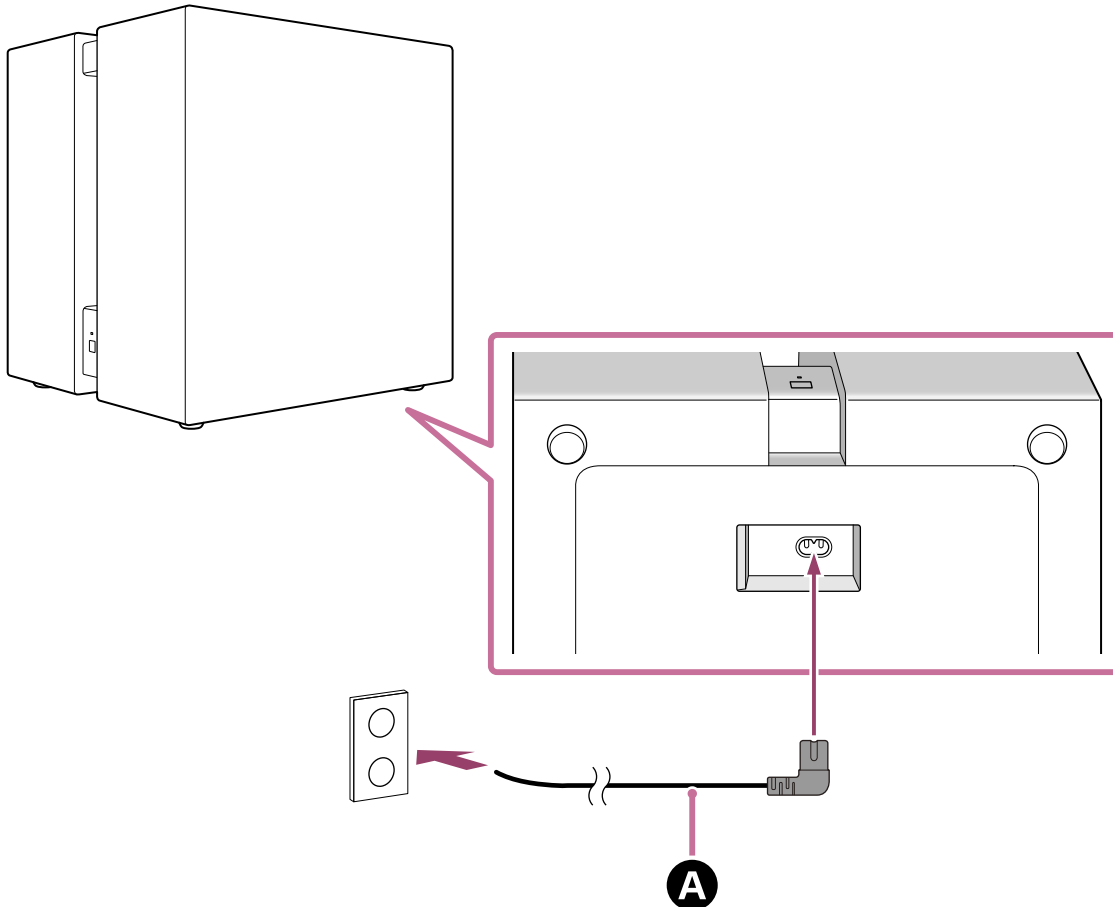

**BRAVIA Theatre Sub 8**

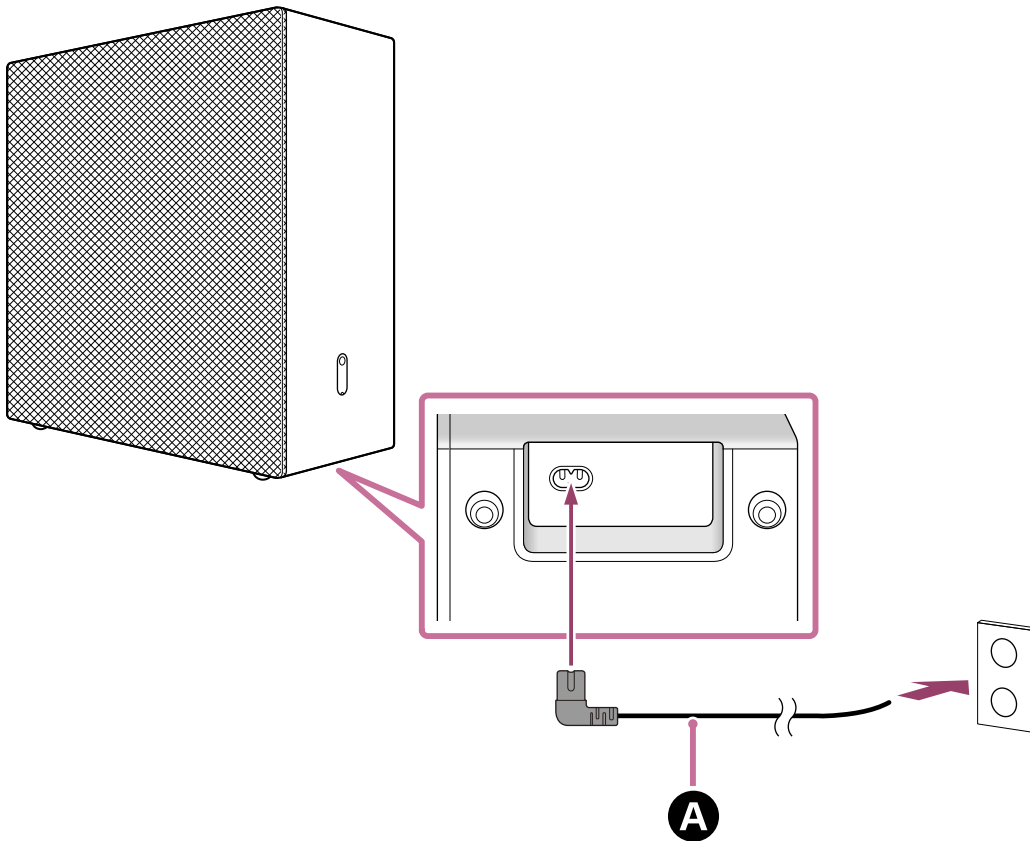

**A** AC power cord (mains lead) (supplied)

**4** Check that the power indicator on the subwoofer lights in white.

When the power indicator lights in white, the connection between the subwoofer and the AV receiver/amplifier is complete.

**Note**

- The Help Guide for the AV receiver/amplifier may state that the power indicator lights in green, but the power indicator on the subwoofer is white.

**BRAVIA Theatre Sub 9**

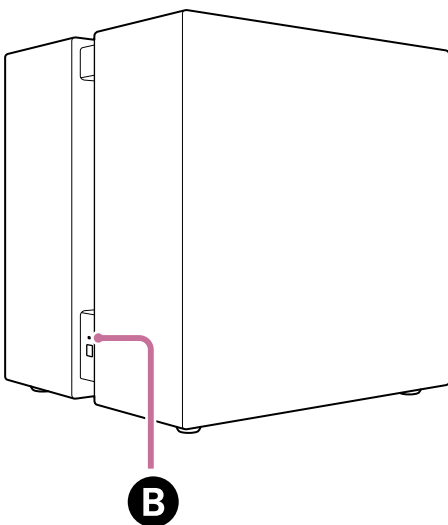

**BRAVIA Theatre Sub 8**

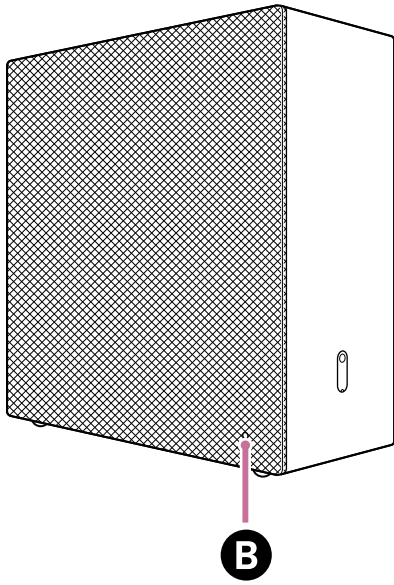

**B** Power indicator

**If the subwoofer does not automatically connect to the AV receiver/amplifier or if you replace another subwoofer that is already connected to the AV receiver/amplifier with this subwoofer**

The subwoofer must be connected manually to the AV receiver/amplifier. For instructions on how to connect manually, refer to “Connecting Sony wireless rear speakers/subwoofer” in the Help Guide for the AV receiver/amplifier. You can connect the subwoofer to the AV receiver/amplifier with the same operation.

**Note**

- If the optional rear speaker has been connected already, it must also be connected manually again.

**5** Press HOME on the remote control supplied with the AV receiver/amplifier and perform sound field optimization by selecting [Setup] - [Speaker Settings] - [Auto Calibration] in the home menu.

**Related Topic**

- [Installing on the Floor or Shelf](#)

TP1002102719

Subwoofer

BRAVIA Theatre Sub 9/ BRAVIA Theatre Sub 8

## Troubleshooting

---

If you have any problems, please follow the process below.

**1. Check that the AC power cord (mains lead) of the subwoofer is firmly and fully inserted all the way.**



**2. Disconnect the AC power cord (mains lead) from the AC outlet (mains), and then reconnect after several minutes.**



**3. Check for applicable problems and solutions by using one of the following methods.**

- Select Help from the menu on the “Sony | BRAVIA Connect” app for support information.
- On the support page, select the model name of the subwoofer and check the support information. For the URL of the support page, see “[Customer Support Website](#).”



**4. Reset the subwoofer.**

All the subwoofer settings are returned to their initial state.



**5. If the subwoofer still does not work properly, consult Sony support contact or your nearest Sony dealer.**

- Sony support contact:  
<https://www.sony.net/support-contact>

---

### Related Topic

- [Resetting the Subwoofer](#)
- [Customer Support Website](#)

TP1002102720

Subwoofer

BRAVIA Theatre Sub 9/ BRAVIA Theatre Sub 8

## Customer Support Website

---

On the support page, you can find the following information.

See the support page for your country/region.

- Questions & Answers
- Latest Drivers and software update
- Contact Support
- Product Repair
- Register Your Product

### For customers in the USA, Canada and Latin America:

<https://www.sony.com/am/support>

### For customers in Europe:

<https://www.sony.eu/support/>

### For customers in Mainland China:

<https://service.sony.com.cn/>

### For customers in Asia-Pacific, Oceania, the Middle East and Africa:

<https://www.sony-asia.com/support>

### For customers in Japan:

<https://www.sony.jp/support/>

TP1002102721

Subwoofer

BRAVIA Theatre Sub 9/ BRAVIA Theatre Sub 8

## Resetting the Subwoofer

If the subwoofer still does not operate properly with "[Troubleshooting](#)," reset the subwoofer.

- 1 With the power on, press and hold LINK on the subwoofer for more than 10 seconds until the notification sound indicating the start of reset plays.**

The reset starts when the power indicator on the subwoofer flashes in white/blue alternately and the notification sound indicating the start of reset is played. When the reset is complete, the power indicator will stop flashing, the notification sound indicating the power off will play, and the subwoofer will turn off.

- 2 Press LINK on the subwoofer to turn on the subwoofer.**

When you connect the subwoofer again, follow the connection procedure to operate. Depending on the connected device, the subwoofer automatically connects to it when the subwoofer is turned on.

### Related Topic

- [About the Indicator](#)
- [Connecting to a Main Audio Device such as a Sound Bar that Supports the "Sony | BRAVIA Connect" App](#)
- [Connecting to an HT-A7000, HT-A5000, or HT-A3000 Sound Bar](#)
- [Connecting to an HT-A9](#)
- [Connecting to an STR-AN1000, STR-AZ7000ES, STR-AZ5000ES, STR-AZ3000ES, STR-AZ1000ES, or TA-AN1000 AV Receiver/Amplifier](#)

TP1002102722

Subwoofer

BRAVIA Theatre Sub 9/ BRAVIA Theatre Sub 8

## Specifications

---

### Subwoofer (YY2102C/ YY2103C)

#### Speaker section

##### Speaker

###### YY2102C (SA-SW9):

200 mm (7 7/8 in) cone type (2)

###### YY2103C (SA-SW8):

200 mm (7 7/8 in) cone type (1)

##### Speaker system

###### YY2102C (SA-SW9):

Sealed type

###### YY2103C (SA-SW8):

Bass reflex type

#### Wireless LAN section

##### Communication system

IEEE 802.11 a/b/g/n/ac/ax

#### BLUETOOTH section

##### Output

BLUETOOTH Specification Power Class 1.5

##### Maximum communication range

Line of sight approx. 30 m (98.4 ft)\*

\* The actual range will vary depending on factors such as obstacles between devices, magnetic fields around a microwave oven, static electricity, cordless phone use, reception sensitivity, the operating system, software applications, etc.

##### Frequency band

2.4 GHz band (2.400 0 GHz - 2.483 5 GHz)

#### Wireless transmitter/receiver section

##### Communication system

Wireless Sound Specification

##### Modulation method

OFDM

#### General

##### Power consumption

###### YY2102C (SA-SW9):

On: 100 W

###### YY2103C (SA-SW8):

On: 55 W

Network standby mode: 2.0 W or less

Turned off: 0.3 W or less

When the [Auto Standby] function is enabled, if the product is not being operated and there is no signal input for about 20 minutes, the product automatically enters the network standby mode or turned off.

Disabling the [Auto Standby] function will increase the power consumption of this product.

When this product is connected to home audio equipment, the power of the product is controlled in conjunction with the auto standby function of home audio equipment.

### **Dimensions\* (W × H × D)**

\* Including projecting parts and controls.

#### **YY2102C (SA-SW9):**

Approx. 390 mm × 400 mm × 350 mm (15 3/8 in × 15 3/4 in × 13 7/8 in)

#### **YY2103C (SA-SW8):**

Approx. 390 mm × 400 mm × 170 mm (15 3/8 in × 15 3/4 in × 6 3/4 in)

### **Mass**

#### **YY2102C (SA-SW9):**

Approx. 23.3 kg (51 lb 6 oz)

#### **YY2103C (SA-SW8):**

Approx. 12.2 kg (26 lb 15 oz)

### **Note**

- Design and specifications are subject to change without notice.
- Refer to the Reference Guide included with your product, which may contain specification information not listed above.

TP1002102723

Subwoofer

BRAVIA Theatre Sub 9/ BRAVIA Theatre Sub 8

## Trademarks

---

- The BLUETOOTH® word mark and logos are registered trademarks owned by Bluetooth SIG, Inc. and any use of such marks by Sony Group Corporation and its subsidiaries is under license.
- QR Code is a registered trademark of DENSO WAVE INCORPORATED in Japan and in other countries and regions.
- “BRAVIA” and “BRAVIA Sync” are registered trademarks or trademarks of Sony Group Corporation or its affiliates.

All other trademarks and registered trademarks are trademarks or registered trademarks of their respective holders. In this manual, ™ and ® marks are not specified.

TP1002102724

Subwoofer

BRAVIA Theatre Sub 9/ BRAVIA Theatre Sub 8

## Licenses

---

- This product contains software that Sony uses under a licensing agreement with the owner of its copyright. We are obligated to announce the contents of the agreement to customers under requirement by the owner of copyright for the software. Please access the following URL and read the contents of the license.  
<https://rd1.sony.net/help/ht/sl/26d/>
- The software included in this product contains copyrighted software that is licensed under the GPL/LGPL and other licenses which may require access to source code. You may find a copy of the relevant source code as required under the GPL/LGPL (and other licenses) at the following URL. You may obtain the source code as required by the GPL/LGPL on a physical medium from us for a period of three years after our last shipment of this product by applying through the form at the following URL. This offer is valid to anyone in receipt of this information.  
<https://oss.sony.net/Products/Linux/>  
Please note that Sony cannot answer or respond to any inquiries regarding the content of this source code.
- Network services, content and the (operating system and) software of this product may be subject to individual terms and conditions and changed, interrupted or discontinued at any time and may require fees, registration and credit card information.

TP1002102725

Subwoofer

BRAVIA Theatre Sub 9/ BRAVIA Theatre Sub 8

## Notes on Use

---

### Precautions

- The supplied AC power cord (mains lead) is designed exclusively for this subwoofer. It should not be used with any other device.
- Unplug the AC power cord (mains lead) from the AC outlet (mains) when the subwoofer is not being used for long periods of time. When unplugging the AC power cord (mains lead) from the AC outlet (mains), always unplug it by holding the plug. Never pull the cord itself.
- If the AC power cord (mains lead) is damaged, contact Sony support or the store you purchased the product from for a replacement.

### On placement

- Do not place the subwoofer near heat sources or in a location subject to direct sunlight, excessive dust, or mechanical shock. These conditions may cause malfunction.
- Place this subwoofer on a flat, level surface. When placed on a sloped surface, the subwoofer may fall over or fall off the surface due to its own vibration, resulting in injuries, malfunctions, or performance degradation.
- Placing the subwoofer on a floor that is coated with special paint, wax, grease, or solvent, etc. may result in discoloration or stains on the floor.
- The speakers of this subwoofer are not the magnetically shielded type. Do not place magnetic cards on the subwoofer or near it.
- Do not place metal objects other than a TV around the subwoofer. Wireless functions may become unstable.
- When the subwoofer is used with a tuner, TV, or VCR, noise or distorted images may be produced. In this case, install the subwoofer away from these devices.
- Do not place the subwoofer near objects that emit a strong magnetic field, such as microwave ovens or large speakers.

### How to care for the subwoofer

- You can use the subwoofer more comfortably and for a longer period of time by following the maintenance procedure below.
  - Clean the subwoofer with a soft cloth slightly moistened with neutral detergent. Do not use any type of abrasive pad, scouring powder, or solvent such as alcohol or benzine.

### On BLUETOOTH® communications

- BLUETOOTH wireless technology is a short-range wireless technology that enables communication between digital devices, such as smartphones and computers. The maximum communication range may vary depending on the presence of obstacles (people, metal objects, walls, etc.) or the electromagnetic environment.
- Microwaves that are generated by a BLUETOOTH device may affect the operation of electronic medical devices. Turn off the subwoofer and other BLUETOOTH devices in the following locations, as it may cause an accident:
  - In hospitals, near priority seating on trains, locations where inflammable gas is present, near automatic doors, or near fire alarms.
- This subwoofer supports security functions that comply with the BLUETOOTH security standard during communication using BLUETOOTH wireless technology. However, depending on the configured settings and other factors, this security may be insufficient. Be careful when using BLUETOOTH communication.
- Sony shall assume no responsibility for any damages or loss resulting from data leaks that may occur when using BLUETOOTH communications.

## Other notes

- The temperature of the subwoofer may rise during use. This is not a malfunction.
- Do not insert foreign objects from the opening of the speaker.
- If a foreign object or water gets into the subwoofer, turn off the subwoofer immediately, unplug the subwoofer from the AC outlet (mains), and consult with Sony support or the store you purchased the product from.
- If you have any questions or problems concerning this subwoofer, consult with Sony support or the store you purchased the product from.

---

### Related Topic

- [Troubleshooting](#)
- [Customer Support Website](#)

TP1002221170

5-071-616-11(1) Copyright 2026 Sony Corporation