

Color Video Camera
BRC-AM7

This guide describes the configuration and operation of the BRC-AM7 Color Video Camera.

Refer to this manual and the operating instructions for related devices as required.

Overview

Typical Usage Applications

[System Configuration](#)

[Controlling a Single Unit Using the Supplied Infrared Remote Control](#)

[Controlling a Single Unit Using a Tablet or Computer](#)

[Controlling a Single Unit Using an External Remote Controller](#)

[Controlling Multiple Units Using an External Remote Controller](#)

Location and Function of Parts

[Front View](#)

[Connector Block](#)

[Side View](#)

[Bottom View](#)

[Location and Function of Parts of the Infrared Remote Control \(supplied\)](#)

Web App Screen

[Web App Screen Overview](#)

[Structure of Common Area of Screens](#)

[Structure of the Live Operation Screen](#)

[Structure of the PTZ AFR Settings Screen](#)

[Structure of the Playback Operation Screen](#)

[Structure of the Settings Screen](#)

[Camera Menu](#)

[Camera Screen Display](#)

Preparation

Mounting the Unit

[Mounting Upright in a Fixed Location](#)

[Mounting Upright in a High, Fixed Location](#)

[Mounting on a Ceiling](#)

[Connecting Cables](#)

[Connecting the Unit to a Network Device Via Wired Connection](#)

[Connecting to the Unit using a Remote Controller \(Option\) via RS-422](#)

Connecting a Power Supply

[Using DC Power](#)

[Using PoE++ Power](#)

[Resetting the Pan/Tilt](#)

Configuring Before Shooting

Initializing the Unit Using the Web App

[Accessing the Web App from a Web Browser](#)

[Initializing the Unit](#)

[Resetting Unit Settings](#)

[Configuring Basic Operation](#)

Preparing Memory Cards

[Memory Cards](#)

[Recommended Memory Cards](#)

[Inserting Memory Cards](#)

[Ejecting a Memory Card](#)

[Formatting \(Initializing\) Memory Cards](#)

[Checking the Remaining Recording Time](#)

[Restoring Memory Cards](#)

Shooting

Basic Operation

[Starting/Stopping Recording](#)

[Switching Between Memory Cards](#)

[Checking the Audio](#)

[Specifying Time Data](#)

[Reviewing the Recording_\(Rec Review\)](#)

Adjusting the Framing

[Framing Adjustment Screen](#)

Adjusting the Shooting Direction

- [Adjusting the Shooting Direction Using the Web App](#)
 - [Setting the Pan/Tilt Operating Speed](#)
 - [Setting the Pan/Tilt Operation Acceleration](#)
 - [Adjusting the Shooting Direction Using the Supplied Infrared Remote Control](#)
-

Adjusting the Zoom

- [Setting the Zoom Type](#)
 - [Adjusting the Zoom Using the Web App](#)
 - [Setting the Zoom Operating Speed Using the Web App](#)
 - [Adjusting the Zoom Using the Supplied Infrared Remote Control](#)
-

Saving/Restoring the Camera Pan/Tilt/Zoom Position

- [Saving/Restoring Pan/Tilt, Zoom Position, and Focus Setting Using the Web App](#)
 - [Renaming Preset Positions Using the Web App](#)
 - [Replacing a Saved Preset Position with a New Position Using the Web App](#)
 - [Deleting a Saved Preset Position Using the Web App](#)
 - [Changing the Transition Speed \(Pan-Tilt/Zoom/Focus\) When Restoring a Preset Position](#)
 - [Saving/Restoring Pan/Tilt and Zoom Position Using the Supplied Infrared Remote Control](#)
-

Automatic Camera Framing (PTZ Auto Framing)

- [About PTZ Auto Framing](#)
- [Configuring PTZ Auto Framing Initial Settings](#)
- [Specifying the Subjects for Automatic Tracking \(manual tracking start mode\)](#)
- [Selecting Subjects in a Specified Position and Tracking Automatically \(auto tracking start mode\)](#)
- [Recalling a PTZ Auto Framing Composition Preset](#)
- [Renaming a PTZ Auto Framing Composition Preset](#)
- [Switching a PTZ Auto Framing Composition Preset to a New Preset](#)
- [PTZ Auto Framing Using the Supplied Infrared Remote Control](#)
- [Checking the PTZ Auto Framing Status Remotely](#)

Adjusting the Focus

[Focus Adjustment Screen](#)

Adjusting the Focus Manually (Manual Focus)

- [Adjusting the Focus Manually Using the Web App](#)
 - [Adjusting the Focus Manually Using the Supplied Infrared Remote Control](#)
 - [Focusing by Specifying a Focus Position \(Spot Focus\)](#)
 - [Using Auto Focus Temporarily \(Push Auto Focus \(AF\)\)](#)
-

Adjusting the Focus Automatically (Auto Focus)

- [Adjusting the Focus Automatically Using the Web App](#)
 - [Adjusting the Focus Automatically Using the Supplied Infrared Remote Control](#)
 - [Setting the Auto Focus Area/Position \(Focus Area\)](#)
 - [Changing the Focus Area Quickly \(Focus Setting\)](#)
 - [Moving the Focus Area Frame Using Touch Operation \(Touch Focus Area\)](#)
 - [Adjusting the Auto Focus Operation \(AF Transition Speed, AF Subject Shift Sensitivity\)](#)
 - [Setting the Auto Focus Target Manually \(AF Assist\) Using the Web App](#)
 - [Focusing Manually During Auto Focus Using the Supplied Infrared Remote Control](#)
 - [Using Manual Focus Temporarily During Auto Focus \(Push Manual Focus\)](#)
-

[Detecting and AF Tracking a Person](#)

[AF Tracking a Specified Subject \(Realtime Tracking AF\)](#)

Adjusting the Brightness

[Brightness Adjustment Screen](#)

[Setting the Target Level for Automatic Brightness Adjustment](#)

Adjusting the Iris

- [Adjusting the Iris Automatically](#)
 - [Adjusting the Iris Manually](#)
-

Adjusting the Gain

- [Adjusting the Gain Automatically](#)
 - [Adjusting the Gain Manually](#)
-

Adjusting the Shutter

- [Adjusting the Shutter Automatically](#)
-

[Adjusting the Shutter Manually](#)

Adjusting the Light Level (ND Filter)

[About the ND Filter](#)

[Adjusting in Preset Mode](#)

[Adjusting Automatically in Variable Mode](#)

[Adjusting Manually in Variable Mode](#)

Adjusting for Natural Colors (White Balance)

[White Balance Adjustment Screen](#)

[Adjusting the White Balance Automatically](#)

[Adjusting the White Balance Manually](#)

[Running Auto White Balance](#)

Configuring the Audio to Record

[Audio Configuration Screen](#)

[Selecting the Audio Input Device](#)

[Adjusting the Audio Recording Level Automatically](#)

[Adjusting the Audio Recording Level Manually](#)

Useful Functions

[Direct Menu Operation](#)

[Assignable Buttons](#)

[Slow & Quick Motion](#)

[Recording to Memory Cards A and B Simultaneously \(2-slot Simul Rec\)](#)

[Video Signal Monitor](#)

[Clip Flags](#)

Proxy Recording

[Proxy Recording Overview](#)

[Recording a Proxy](#)

Shooting with the Desired Look

[Look Overview](#)

[Selecting a Look](#)

[Importing a Desired Base Look](#)

[Customizing a Look](#)

[Saving a Look](#)

[Deleting a Base Look](#)

Shooting with Look Adjustment in Post-Production

[Shooting with Look Adjustment in Post-Production](#)

[Applying a LUT to SDI2 Output/HDMI Output and Streaming](#)

[Changing a LUT](#)

Saving and Loading Configuration Data

[Saving and Loading Configuration Data Overview](#)

[Saving an ALL File](#)

[Loading an ALL File](#)

Network Functions

Transferring Files

[About File Transfer](#)

[Registering a File Transfer Destination](#)

[Transferring Recorded Proxy Clips Sequentially](#)

Selecting a File and Uploading

[Uploading a Proxy Clip on a Memory Card from the Thumbnail Screen](#)

[Uploading an Original Clip on a Memory Card from the Thumbnail Screen](#)

[Checking the File Transfer Status](#)

[Uploading Using Secure FTP](#)

Configuring Streaming

[About Streaming](#)

[Setting the Streaming Format](#)

[Setting the Video Codec for Streaming](#)

[Setting the Audio Codec for Streaming](#)

[Starting/Stopping Streaming](#)

Thumbnail Screen

[Thumbnail Screen](#)

Playing Clips and Other Clip Operations

[Playing Recorded Clips](#)

[Operations on Recorded Clips](#)

Camera Menu and Detailed Settings

[Camera Menu Configuration](#)

Operating the Camera Menu

[Operating the Camera Menu](#)

[Entering a Character String](#)

User Menu

[\[User\]](#)

Edit User Menu

[\[Edit User\]](#)

Shooting Menu

[\[ISO/Gain\]](#)

[\[ND Filter\]](#)

[\[Shutter\]](#)

[\[Auto Exposure\]](#)

[\[White\]](#)

[\[White Setting\]](#)

[\[Offset White\]](#)

[\[Focus\]](#)

[\[S&Q Motion\]](#)

[\[LUT On/Off\]](#)

[\[NIGHTSHOT\]](#)

[\[Noise Suppression\]](#)

[\[Flicker Reduce\]](#)

Project Menu

[\[Base Setting\]](#)

[\[Rec Format\]](#)

[\[Flexible ISO Setting\]](#)

[\[Simul Rec\]](#)

[\[Proxy Rec\]](#)

[\[SDI/HDMI Rec Control\]](#)

[\[Assignable Button\]](#)

Paint/Look Menu

[\[Scene File\]](#)

[\[Base Look\]](#)

[\[Reset Paint Settings\]](#)

[\[Black\]](#)

[\[Knee\]](#)

[\[Detail\]](#)

[\[Matrix\]](#)

[\[Multi Matrix\]](#)

Pan-Tilt Menu

[\[P/T Acceleration\]](#)

TC/Media Menu

[\[Timecode\]](#)

[\[TC Display\]](#)

[\[Users Bit\]](#)

[\[HDMI TC Out\]](#)

[\[Clip Name Format\]](#)

[\[Update Media\]](#)

[\[Format Media\]](#)

[\[Media Life\]](#)

Monitoring Menu

[\[Output Format\]](#)

[\[Display On/Off\]](#)

[\[Video Signal Monitor\]](#)

[\[Marker\]](#)

Audio Menu

[\[Audio Input\]](#)

[\[Audio Output\]](#)

Thumbnail Menu

[\[Display Clip Properties\]](#)

[\[Set Clip Flag\]](#)

[\[Lock/Unlock Clip\]](#)

[\[Delete Clip\]](#)

[\[Copy Clip\]](#)

[\[Transfer Clip\]](#)

[\[Transfer Clip \(Proxy\)\]](#)

[\[Filter Clips\]](#)

[\[Customize View\]](#)

Technical Menu

[\[Color Bars\]](#)

[\[Genlock\]](#)

[\[Tally\]](#)

[\[Rec Review\]](#)

[\[Zoom\]](#)

[\[Lens\]](#)

[\[APR\]](#)

Network Menu

[\[Wired LAN\]](#)

[\[File Transfer\]](#)

Maintenance Menu

[\[Language\]](#)

[\[Hours Meter\]](#)

Shooting Menu Settings and Default Values

[\[ISO/Gain\] Settings and Default Values](#)

[\[AGC Limit\] Settings and Default Values](#)

[\[Video Format\] / \[Quality\] / \[Bit Rate\] Settings](#)

[Image Quality Settings Saved for Each Shooting Mode](#)

Web Menu and Detailed Settings

[Web Menu Configuration](#)

[Web Menu Operations](#)

Shooting Menu

[\[Focus\]](#)

Project Menu

[\[Base Setting\]](#)

[\[Rec Format\]](#)

[\[Simul Rec\]](#)

[\[Proxy Rec\]](#)

[\[All File\]](#)

Paint/Look Menu

[\[Base Look\]](#)

Pan-Tilt Menu

[\[P/T Speed\]](#)

[\[P/T Acceleration\]](#)

[\[P/T Range Limit\]](#)

[\[P/T Direction\]](#)

[\[P/T Preset\]](#)

Monitoring Menu

[\[Output Format\]](#)

[\[Output Display\]](#)

Audio Menu

[\[Audio Input\]](#)

[\[Audio Output\]](#)

Technical Menu

[\[Tracking Data Output\]](#)

[\[Tally\]](#)

[\[IR Remote\]](#)

[\[RCP/MSU\]](#)

Network Menu

[\[Camera Name\]](#)

[\[User\]](#)

[\[Wired LAN\]](#)

[\[File Transfer\]](#)

[\[FTP Server 1\]](#), [\[FTP Server 2\]](#), [\[FTP Server 3\]](#)

[\[SSL\]](#)

[\[SSH\]](#)

[\[Referer Check\]](#)

[\[Brute Force Attack Protection\]](#)

Stream Menu

[\[Stream\]](#)

[\[Video Stream\]](#)

[\[Audio Stream\]](#)

Maintenance Menu

[\[Language\]](#)

[\[Clock Set\]](#)

[\[Reset\]](#)

[\[Information\]](#)

[\[System Log\]](#)

[\[HTTP Access Log\]](#)

[\[Service\]](#)

[\[EULA\]](#)

[\[Software\]](#)

External Device Connection

[Connecting External Monitors and Recording Devices](#)

Connecting an RCP/MSU (option)

[Connecting with an RCP/MSU](#)

[One-to-One Connection Between the Unit and an RCP](#)

[Using the Unit in a Multi Camera Environment with an MSU/Camera Remote Control Software](#)

[List of Supported Functions](#)

Operating Using an RM-IP500 Remote Controller (Option)

[About Operation Using an RM-IP500 Remote Controller \(option\)](#)

[Connecting an RM-IP500 Remote Controller via Wired LAN](#)

Using the Camera Remote SDK

[About the Camera Remote SDK](#)

Synchronizing with an External Device

[About Synchronizing with an External Device](#)

[Synchronizing the Phase of the Video Signal \(Genlock\)](#)

[Locking the Timecode to Other Devices](#)

[Connecting an External Microphone or External Audio Device](#)

[Managing/Editing Clips Using a Computer](#)

[Outputting an Optical Fiber Signal](#)

[Connecting a Tally Signal](#)

[Outputting Tracking Data \(free-d\)](#)

Appendix

[Usage Precautions](#)

[Output Formats and Limitations](#)

[Troubleshooting](#)

[Error/Warning Messages](#)

[List of Menu Items](#)

[Preset Position Saved Items](#)

[Block Diagrams](#)

[Licenses](#)

[Specifications](#)

[Trademarks](#)

5-065-326-11(1) Copyright 2024 Sony Corporation

System Configuration

This unit can be combined with peripheral devices to form various system configurations.

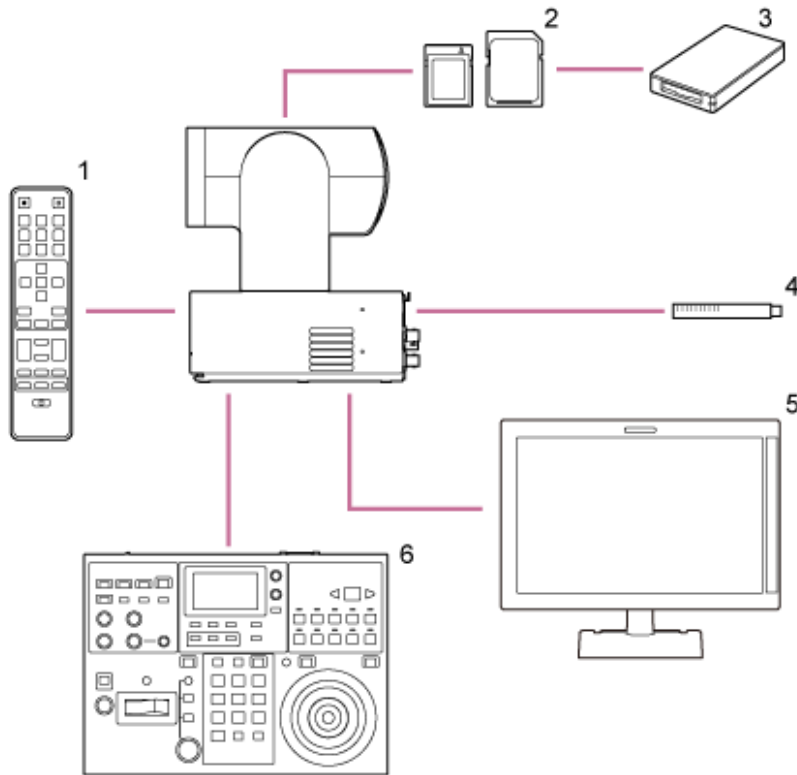

1. Infrared remote control (supplied)
2. CFexpress Type A memory cards / SDXC memory cards
3. CFexpress Type A card reader / SD card reader
4. ECM-678, ECM-674, ECM-680S Microphone*
* EC-0.5X5F3M 5-pin → 3-pin XLR adaptor cable is required.
5. Video monitor
6. RM-IP500 Remote Controller

Color Video Camera
BRC-AM7

Controlling a Single Unit Using the Supplied Infrared Remote Control

You can control a single unit remotely using the supplied infrared remote control.

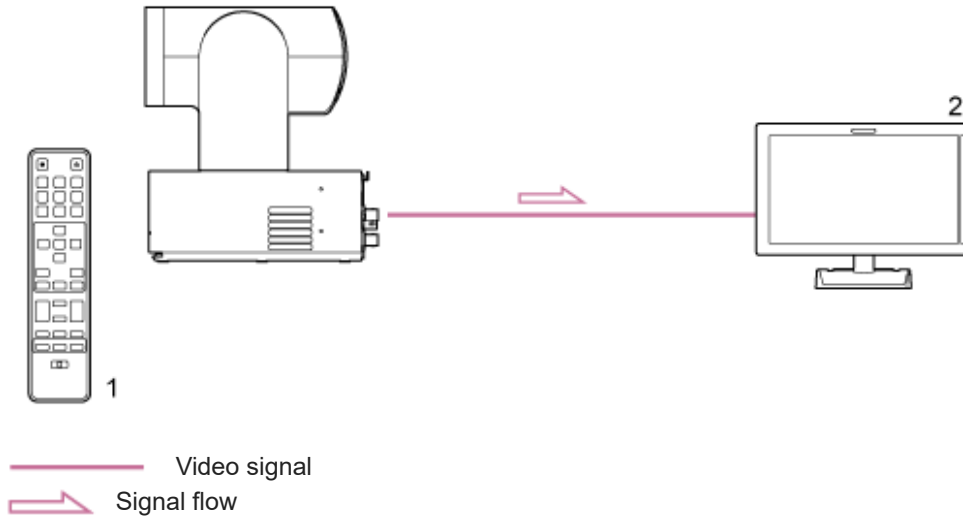

1. Infrared remote control (supplied)

2. Video monitor

TP1001804451

Color Video Camera
BRC-AM7

Controlling a Single Unit Using a Tablet or Computer

You can connect a tablet or computer to the unit and then control the unit using a web browser.

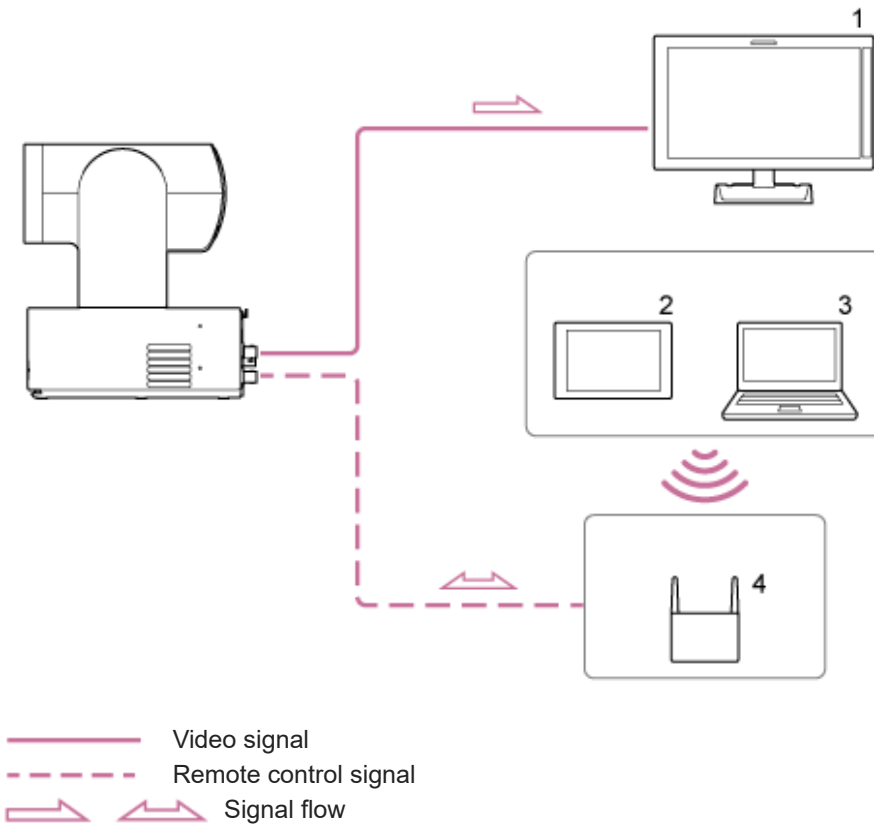

1. Video monitor

2. Tablet

3. Computer

4. Access point

TP1001804452

Color Video Camera
BRC-AM7

Controlling a Single Unit Using an External Remote Controller

You can control the unit remotely using a remote controller.

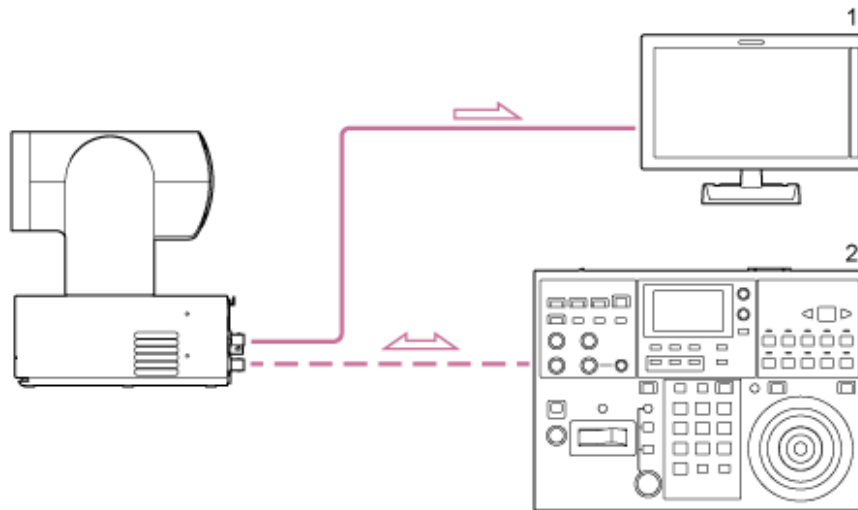

— Video signal
- - - Remote control signal
⇨ ⇨ Signal flow

1. Video monitor

2. RM-IP500 Remote Controller

TP1001804453

Controlling Multiple Units Using an External Remote Controller

VISCA over IP connection

You can control up to 100 units remotely using a single remote controller.

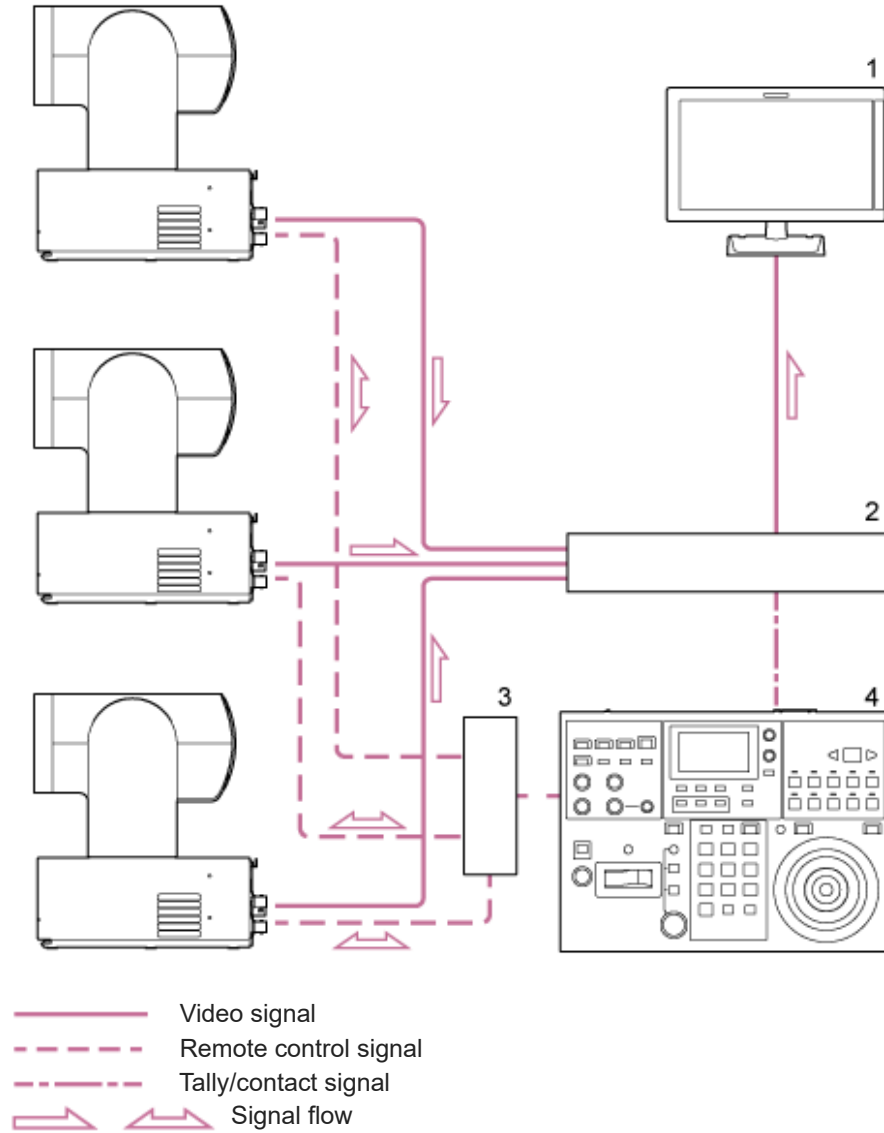

1. Video monitor
2. Video switcher
3. Ethernet hub
4. RM-IP500 Remote Controller

Front View

This topic describes the location and function of parts on the front of the unit.

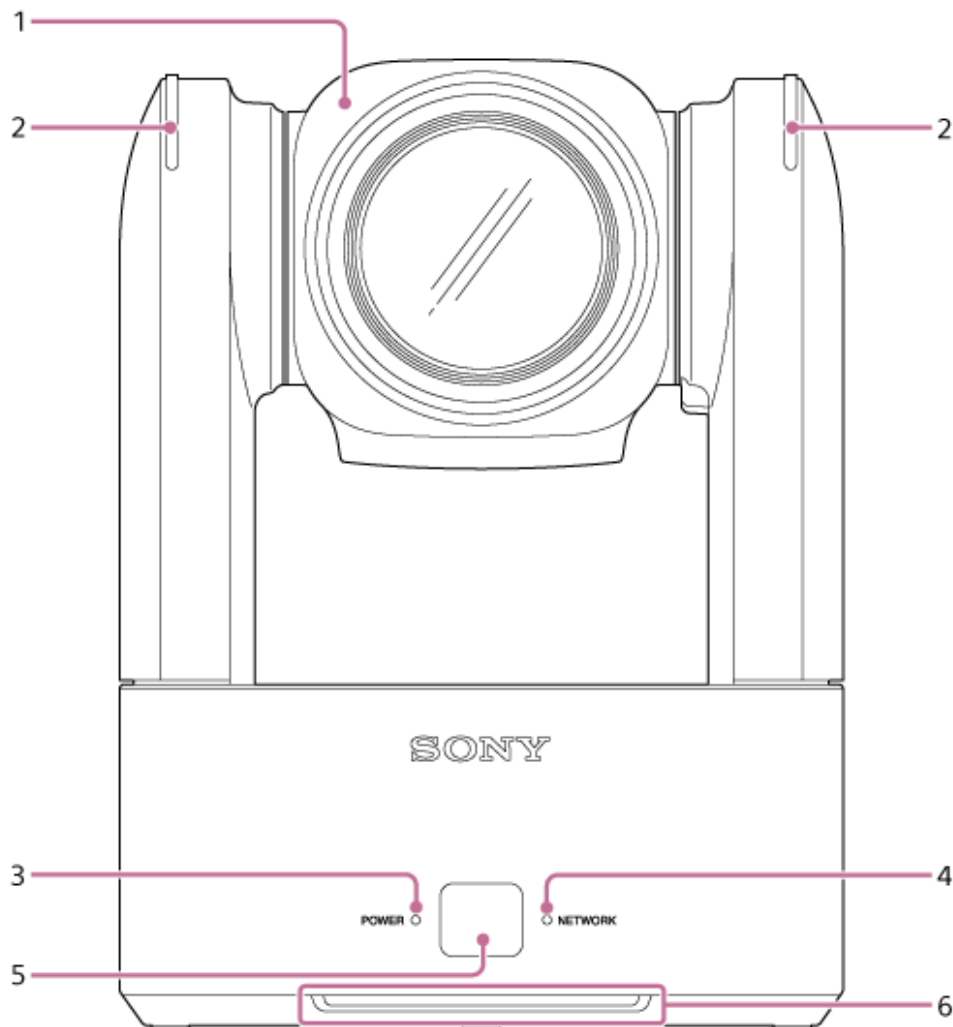

1. Camera head

Note

- Do not subject the camera head to strong impacts.

2. Recording/tally lamp

For details about configuration, see [Technical] – [Tally] – [Tally Control] in the web menu or camera menu.

When set to [Internal] (recording lamp), the lamp lights up red when recording to a memory card. The lamp blinks when the remaining free space on the recording media is low or when an error occurs.

- For details, see “Error/Warning Messages.”

When set to [External] (tally lamp), the lamp lights up red, green, or yellow according to the external tally signal.

- For details, see “Connecting a Tally Signal.”

When set to [PTZ AFR] (PTZ auto framing), the tally lamp lights up or blinks blue according to the auto framing operation status.

- For details, see “Checking the PTZ Auto Framing Status Remotely.”

3. POWER lamp

4. NETWORK lamp

The state of the unit is indicated by the combination of display color and lit status (lit, blinking, not lit) of the POWER lamp and NETWORK lamp.

POWER lamp	NETWORK lamp	Unit status
Lit green ^{*1}	Lit green	Power-on (network connected)
	Not lit	Power-on (network not connected)
Blinking green	Not lit	Power-on process in progress
Blinking orange	Not lit	Power supply standby process in progress
Lit orange	Not lit	Power standby state
Blinking yellow	Not lit	Software update in progress
Blinking orange slowly ^{*2}	Blinking green slowly ^{*2}	The unit cannot operate normally. For details, view the system log. If the problem persists even after putting the unit in standby mode or turning the power off and then on again, contact your Sony service representative.
Blinking orange rapidly ^{*3}	Blinking green rapidly ^{*3}	A malfunction occurred in the unit. Contact your Sony service representative.

*1 Blinks green when a command is received from the supplied infrared remote control.

*2 Blinking slowly: Blinking once per second

*3 Blinking rapidly: Blinking four times per second

5. Infrared remote control sensor

Infrared sensor for the supplied infrared remote control.

6. Air inlet

Note

- Do not block the air flow. Doing so may cause a malfunction.

Related Topic

- [Error/Warning Messages](#)
- [Checking the PTZ Auto Framing Status Remotely](#)
- [Connecting a Tally Signal](#)
- [\[Tally\]](#)
- [\[Tally\]](#)

Connector Block

This topic describes the location and function of parts on the connector block of the unit.

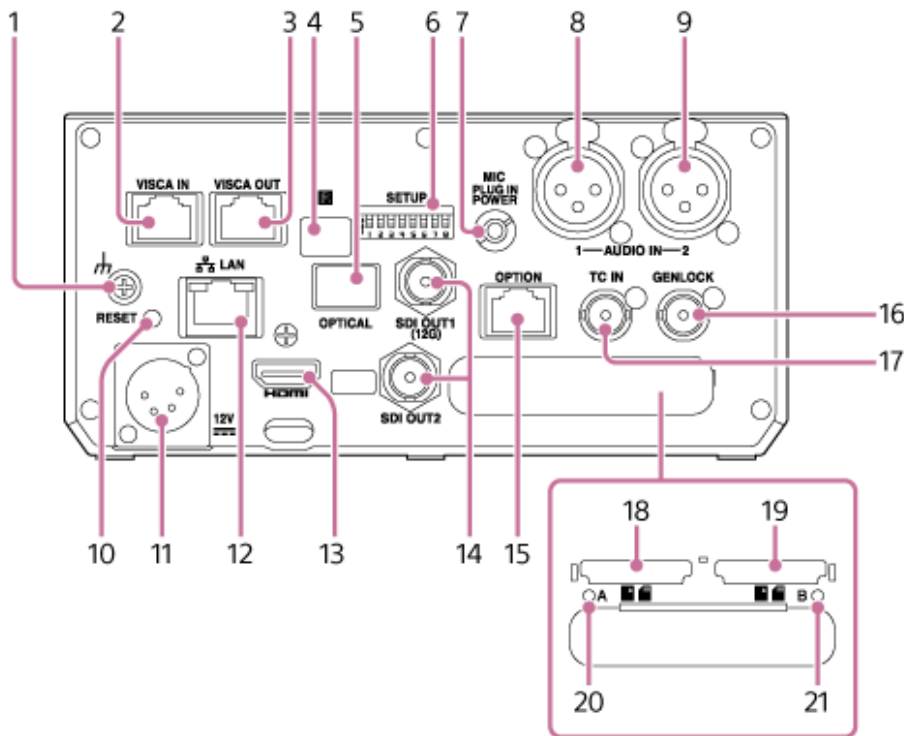

1. ⏏ (ground) connection

Connect to ground by connecting to the ground terminal of a power outlet or to a grounding bar.

2. VISCA IN connector

Connect to a remote controller (option).

When connecting multiple cameras, connect to the VISCA RS-422 OUT connector of the previous camera.

3. VISCA OUT connector

When connecting multiple cameras, connect to the VISCA RS-422 IN connector of the next camera.

4. [IR] Infrared remote control sensor (rear)

Infrared sensor for the supplied infrared remote control.

5. OPTICAL output connector

Outputs an SDI OUT1 (12G) connector signal converted to optical format when an SFP+ module (option) is connected.

- For details, see “Outputting an Optical Fiber Signal.”

6. SETUP switches

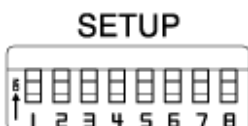

Configures the following settings.

Switch 1, 2: Selects the infrared remote control (supplied) that will perform operations.

Switch 1 setting	Switch 2 setting	Description
OFF (default)	OFF (default)	Receives operations from the infrared remote control (supplied) with remote control ID of 1. Default setting.
OFF	ON	Receives operations from the infrared remote control (supplied) with remote control ID of 2.
ON	OFF	Receives operations from the infrared remote control (supplied) with remote control ID of 3.
ON	ON	Reserved

Switch 3: Sets which settings are reset when the RESET switch is pressed.

Setting	Description
OFF (default)	Resets the network connection settings only. The network settings, security settings, and user information (user name and password) of the unit will be reset.
ON	Resets all settings to factory defaults.

Switch 4: Enables/disables VISCA and VISCA over IP communication. The settings are applied when the camera is turned on.

Set to the ON position to use the unit when connected to an RM-IP500 remote controller.

Setting	Description
OFF (default)	Will not respond to VISCA commands.
ON	Accepts VISCA commands.

Note

- If the administrator password has not been configured, VISCA communication is disabled, regardless of the switch setting. For details about configuring the administrator password, see "Initializing the Unit."

Switch 5: Sets the VISCA IN/VISCA OUT connector baud rate. The settings are applied when the camera is turned on.

Setting	Description
OFF (default)	Sets the baud rate to 9600 bps.
ON	Sets the baud rate to 38400 bps.

Switch 6, 7: Reserved. Not used.

Switch 8: Sets the IP address to a specific value.

Setting	Description
OFF (default)	The user sets the IP address.

Setting	Description
ON	<p>Sets the IP address of the unit to 192.168.0.100 at startup (fixed IP address mode).</p> <p>Note</p> <ul style="list-style-type: none"> If the IP address is changed after startup in the web menu, set this switch to the OFF position.

7. MIC connector (stereo ø3.5 mm)

Connect to a ø3.5 mm stereo mini jack (3-pole) microphone.

8. AUDIO IN 1 connector (XLR type 3-pin connector)

9. AUDIO IN 2 connector (XLR type 3-pin connector)

Use to input the signal from an external microphone or audio device.

- For details, see “Connecting an External Microphone or External Audio Device.”

10. RESET switch

Press for at least 5 seconds using the tip of a pen or similar device to reset the settings of the unit to the factory default values.

You can select whether to reset the network connection settings only or all settings using SETUP switch 3.

11. DC IN connector (XLR type 4-pin connector)

DC IN (DC power input) connector (XLR 4-pin, male) for connecting an external power supply to the unit. Supports an input voltage of 12 V DC (11 V to 17 V).

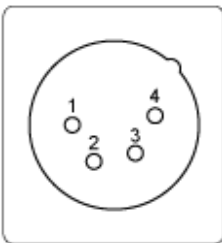

No.	Signal
1	GND
2	NC
3	NC
4	DC IN (11 V to 17 V)

Note

- If the power cable is extended to a long distance, a voltage drop will occur due to the load. Check that the input voltage at the power connector does not fall below 12 V before operating the unit.
- The unit monitors the voltage. If it falls below 11.5 V, [Voltage Low] is detected and a warning is displayed using the Web App, tally, and front LED.
- If it falls below 11.0 V, [Insufficient Voltage] is detected, various functions are stopped, and a warning is displayed using the Web App, tally, and front LED. When [Insufficient Voltage] is detected, the unit will not return to normal operating state if the voltage subsequently rises. Make sure that the power supply is stable, then disconnect the power cable and connect the power supply again.

12. LAN (network) connector (RJ-45)

Connect a network cable (category 5e or higher) for network communication and PoE++* power supply to the unit.

* PoE++: Power over Ethernet Plus Plus. Conforms to IEEE802.3bt (Type 4 Class 8). For details about connecting, refer to the operating instructions for the power supply device.

Note

- Some functions are restricted during PoE++ operation. For details, see “Using PoE++ Power.”

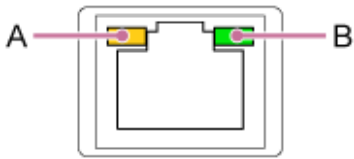

A: Speed LED status indication

Display	Connection speed
Not lit	10 Mbps connection
	100 Mbps connection
Lit orange	1000 Mbps connection

B: Link/ACT LED status indication

Display	Connection status
Not lit	No link
Blinking green	Link established, data active
Lit green	Active link

Note

- When connecting this product to the Internet, connect via a system that provides a protection function, such as a router or firewall. If connected without such protection, security issues may occur.

13. HDMI connector

Outputs the video from the unit as an HDMI signal.

- For details, see “HDMI OUT connector (Type A connector)” in “Connecting External Monitors and Recording Devices.”

14. SDI OUT 1 (12G) connector / SDI OUT 2 connector

SDI OUT 1 (12G) connector: Outputs the video from the unit as a 12G/6G/3G/1.5G SDI signal.

SDI OUT 2 connector: Outputs the video from the unit as a 3G/1.5G SDI signal.

- For details, see “SDI OUT connector (BNC type)” in “Connecting External Monitors and Recording Devices.”

15. OPTION connector

Use to connect a tally signal from an external device.

- For details, see “Connecting a Tally Signal.”

16. GENLOCK connector

Use to input an external sync signal.

- For details, see “Synchronizing the Phase of the Video Signal (Genlock).”

17. TC IN connector

Input an external reference timecode signal.

- For details, see “Locking the Timecode to Other Devices.”

18. CFexpress Type A / SD card slot (A)

19. CFexpress Type A / SD card slot (B)

Use for inserting recording media.

- For details, see “Inserting Memory Cards.”

20. Access indicator A

21. Access indicator B

Indicator is lit or blinks when recording media is inserted.

- For details, see “Inserting Memory Cards.”

Related Topic

- [Connecting an External Microphone or External Audio Device](#)
- [Using PoE++ Power](#)
- [Locking the Timecode to Other Devices](#)
- [Connecting External Monitors and Recording Devices](#)
- [Connecting a Tally Signal](#)
- [Outputting an Optical Fiber Signal](#)
- [Initializing the Unit](#)
- [Synchronizing the Phase of the Video Signal \(Genlock\)](#)
- [Inserting Memory Cards](#)

TP1001804456

Color Video Camera
BRC-AM7

Side View

This topic describes the location and function of parts on the side of the unit.

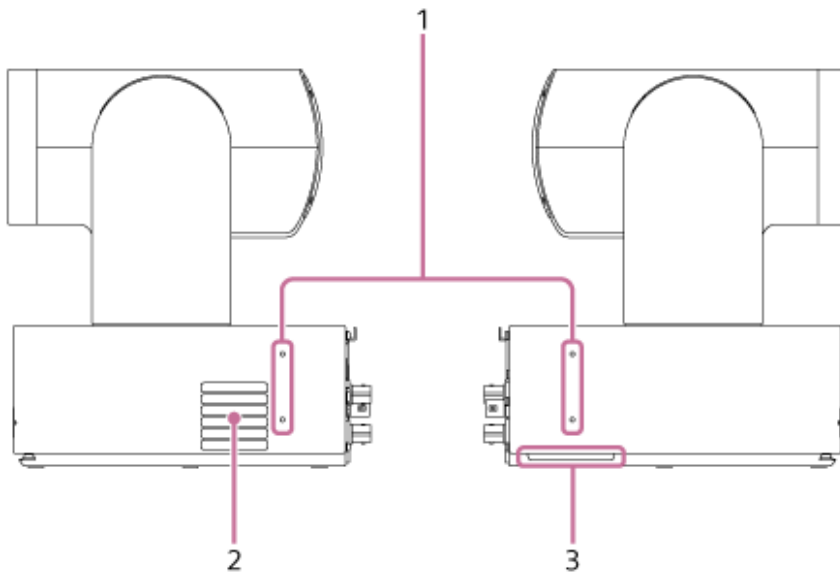

1. Screw holes for external devices (4 places)

For M3 screws of up to 6 mm (1/4 inch) length.

Note

- Do not use screws longer than 6 mm (1/4 inch). Doing so may cause a malfunction.

2. Air outlet

Emits heat from inside the unit.

Note

- Do not cover the air outlet. Doing so may cause a malfunction.
- Note that the area near the air outlet may become hot.

3. Air inlet

Note

- Do not block the air flow. Doing so may cause a malfunction.

TP1001804457

Color Video Camera
BRC-AM7

Bottom View

This topic describes the location and function of parts on the bottom of the unit.

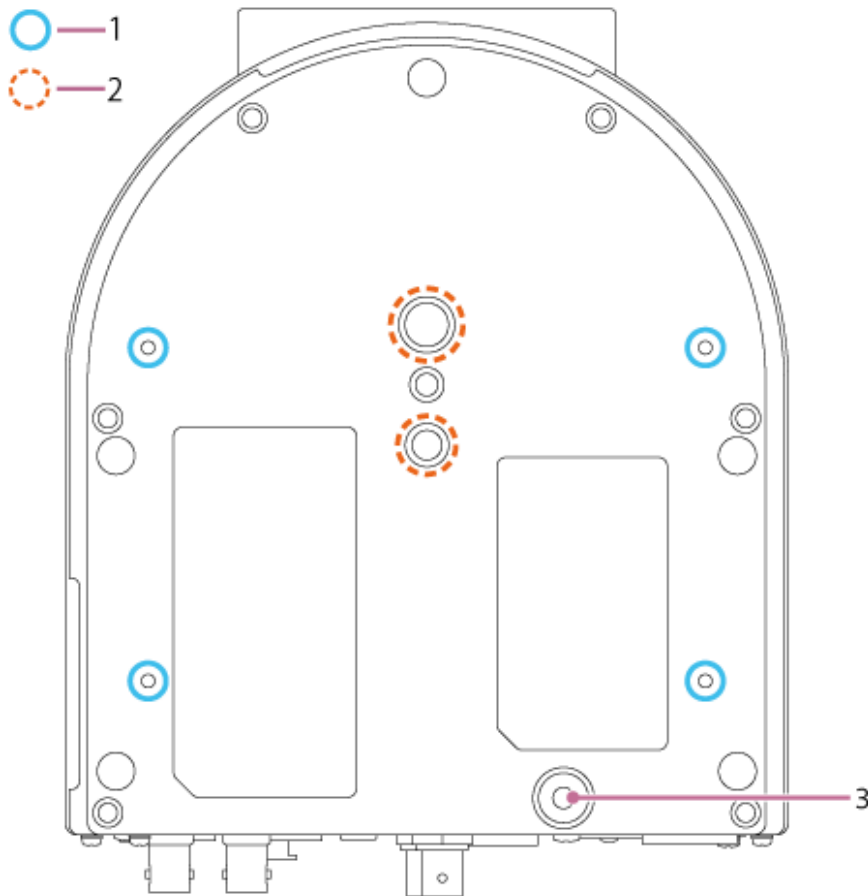

1. Ceiling bracket (A) mounting screw holes (4 places, 5.5 mm (7/32 inch) effective thread depth)

When mounting the unit on a ceiling or a shelf in a high location, attach the supplied ceiling bracket to the screw holes using the four supplied screws.

- For details about mounting, see “Mounting Upright in a High, Fixed Location” and “Mounting on a Ceiling.”

2. Tripod mounting screw holes (1/4 inch, 3/8 inch)

Compatible with 1/4-20 UNC screws and 3/8-16 UNC screws. Attach to a tripod (option, screw length of 5.5 mm (7/32 inch) or less).

Note

- Do not use screws longer than 5.5 mm (7/32 inch). Doing so may cause a malfunction.

3. Fall prevention wire rope mounting screw.

Note

- Attach the supplied wire rope and screws.
- Do not attach the screws without attaching the wire rope.

Location and Function of Parts of the Infrared Remote Control (supplied)

This topic describes the location and function of parts of the infrared remote control (supplied).

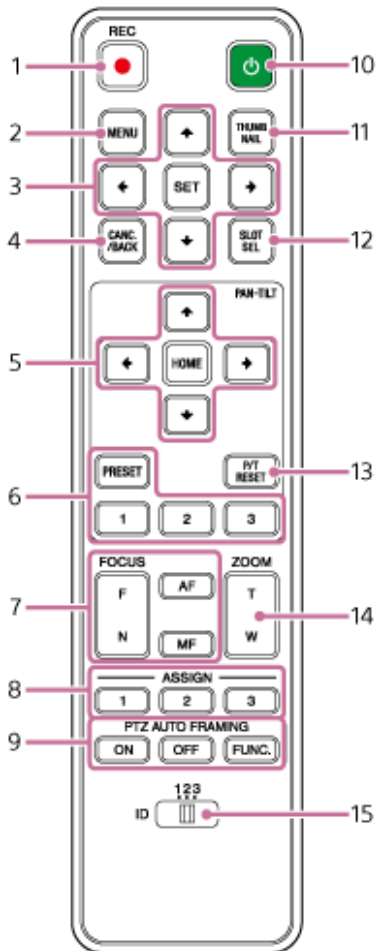

1. REC● (record START/STOP) button

Press to start or stop recording.

2. MENU button

Press to show or hide the camera menu.

3. GUI control buttons

Press to perform operations in the camera menu, in message dialogs that include buttons, and other screen display functions.

4. CANC./BACK button

Press to cancel a setting or to return to the previous screen of the camera menu of the unit.

5. Pan and tilt control buttons

Press the arrow buttons to control the pan/tilt of the camera. Press the HOME button to return the orientation of the camera to face the front.

6. Preset position control buttons

Press and hold the PRESET button and press one of the 1 to 3 buttons to store camera direction, zoom, and focus adjustment status in the pressed number button.

Press a number button with stored settings to recall the saved state.

7. Focus control buttons

Use to adjust the focus.

To adjust the focus automatically, press the AF button.

To adjust the focus manually, press the MF button, then press either the F (Far) button to focus on far subjects or the N (Near) button to focus on near subjects.

8. Assignable buttons 1 to 3

Executes the functions assigned to the assignable buttons using the camera menu.

If you assign the [Direct Menu] function to an assignable button, you can adjust the exposure, white balance, and other settings using the GUI control buttons.

- For details about assignment using the camera menu, see “Assignable Buttons.”
- For details about the direct menu, see “Direct Menu Operation.”

9. PTZ AUTO FRAMING button

ON button: Executes PTZ auto framing.

OFF button: Stops PTZ auto framing.

FUNC.: Not used on the unit.

10. (power) button

Press to turn on the unit from standby state or to switch the power supply to standby state.

11. THUMBNAIL button

Displays the thumbnail screen showing the clips recorded on the memory card of the unit.

- For details about the thumbnail screen, see “Thumbnail Screen.”

You can select clips and control playback on the thumbnail screen using the GUI control buttons.

12. SLOT SEL (memory card slot (A)/(B) select) button

When two memory cards are inserted, press the button to switch between the memory cards for recording.

Press this button while the thumbnail screen is displayed to switch between the memory cards to view.

13. P/T RESET (pan/tilt reset) button

Resets the pan/tilt functions. Press the button when the POWER lamp and NETWORK lamp are blinking simultaneously or when [Execute Pan-Tilt Reset] is displayed in the framing control panel in the Web App.

14. Zoom control buttons

To zoom in, press the T (telephoto) button.

To zoom out, press the W (wide) button.

15. CAMERA SELECT switch

Selects the ID of the camera (this unit) for control by an infrared remote control. The ID of the camera is set using CAMERA SETUP switches 1 and 2 on the connector block.

Note

- If another camera with same ID is positioned nearby, it may also respond to operations from the supplied infrared remote control. If cameras are positioned close together, it is recommended that different IDs be configured.

Infrared remote control battery

The infrared remote control requires two AA (LR6) batteries.

Insert the batteries into the infrared remote control as shown in the following diagram.

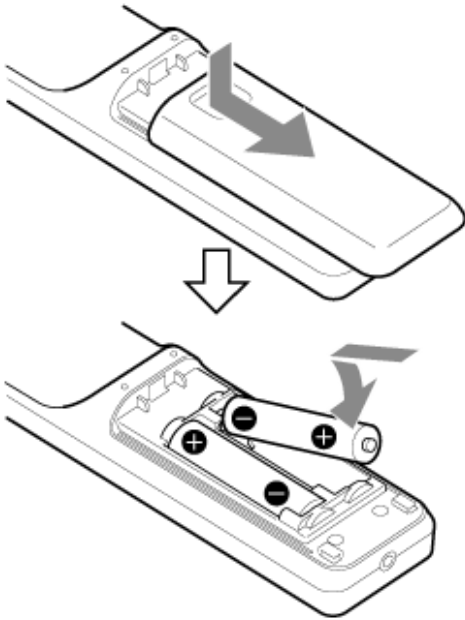

Note

- Do not use any batteries other than manganese or alkaline batteries as they may rupture.
- Dispose of used batteries according to the laws and regulations of the country or region.

Related Topic

- [Assignable Buttons](#)
- [Direct Menu Operation](#)
- [Thumbnail Screen](#)
- [Playing Recorded Clips](#)
- [Operations on Recorded Clips](#)

TP1001804459

Color Video Camera
BRC-AM7

Web App Screen Overview

By connecting a tablet or computer, you can pan/tilt, zoom, record, play recorded video, and configure the unit from a web browser (hereinafter, this function is referred to as the “Web App”).

- For details about launching the Web App, see “Accessing the Web App from a Web Browser.”

Note

- The Web App does not support the camera audio output.

When the Web App launches, the following live operation screen appears.

Live operation screen

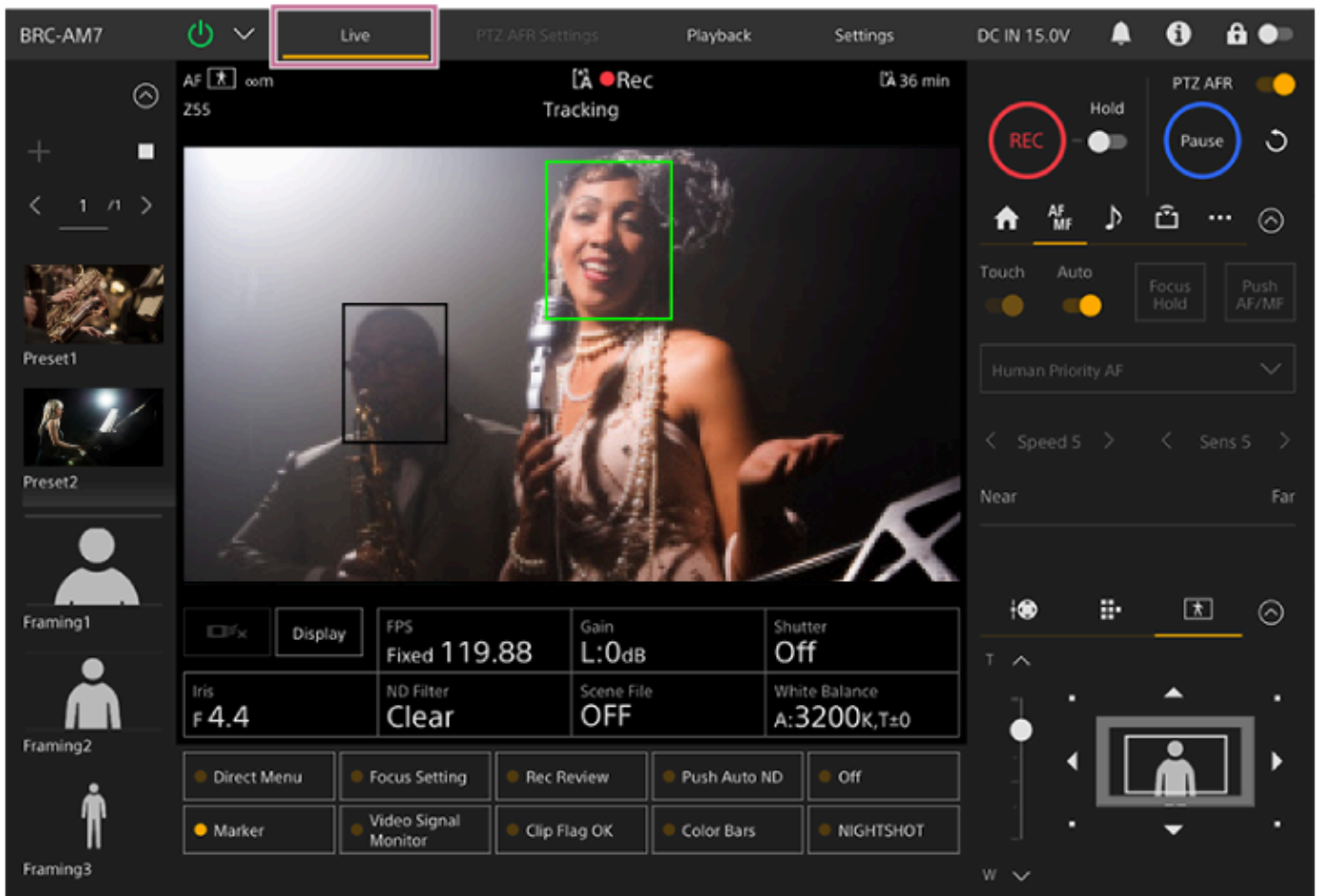

- For details about the live operation screen, see “Structure of the Live Operation Screen.” Buttons and icons common to the live operation screen and playback operation screen are displayed at the top of the screen.
- For details about the common area of the screens, see “Structure of Common Area of Screens.” You can switch between screens by pressing the screen switching tabs in the common area.

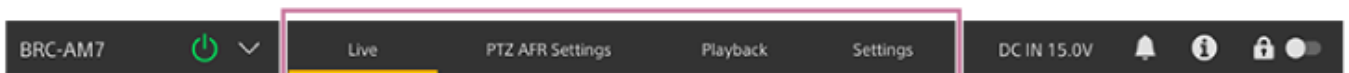

PTZ AFR settings screen

This screen is used to configure the PTZ auto framing initial settings.

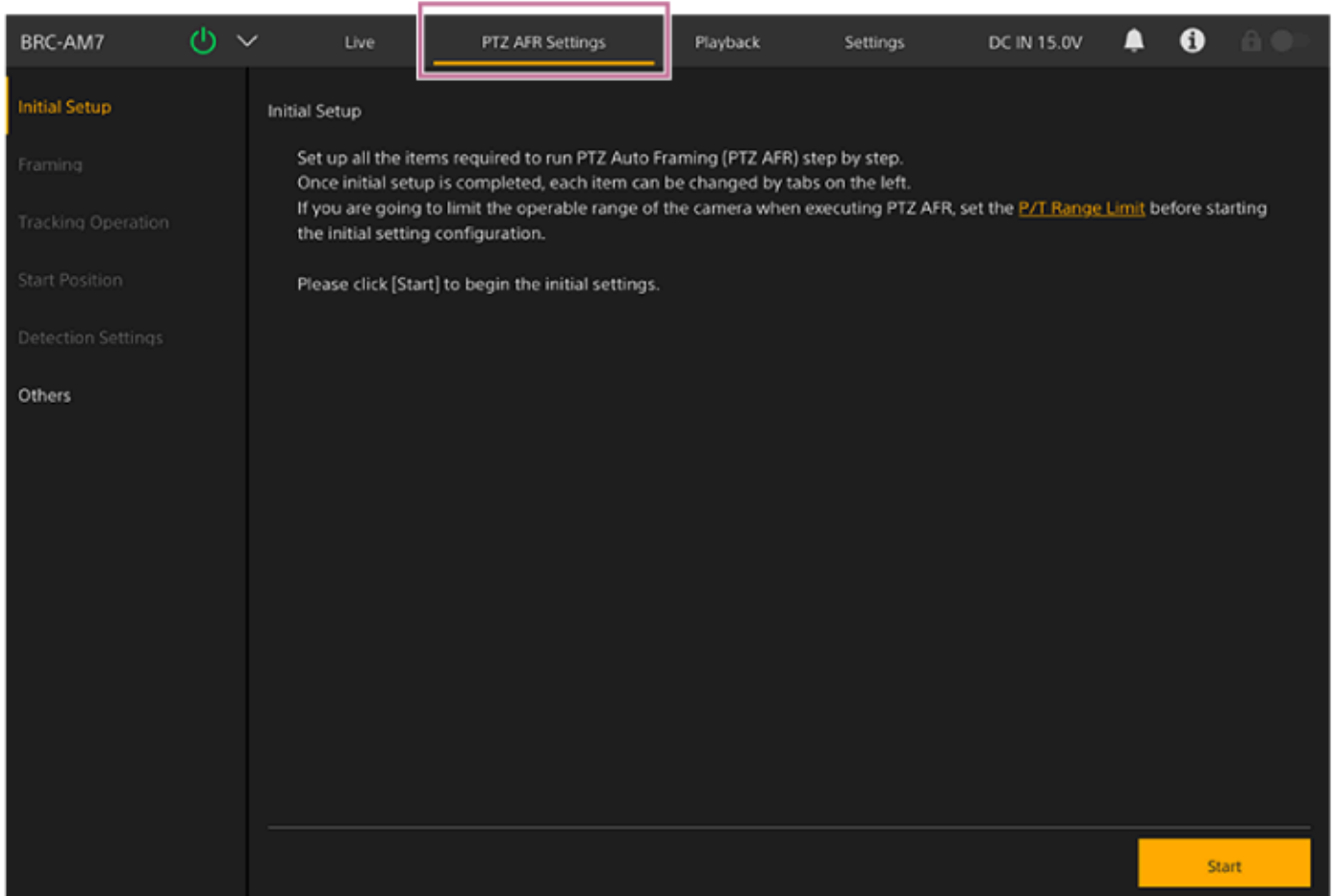

- For configuration, see “Structure of the PTZ AFR Settings Screen” and “Configuring PTZ Auto Framing Initial Settings.”

Playback operation screen

Press the [Playback] tab to display the playback operation screen.

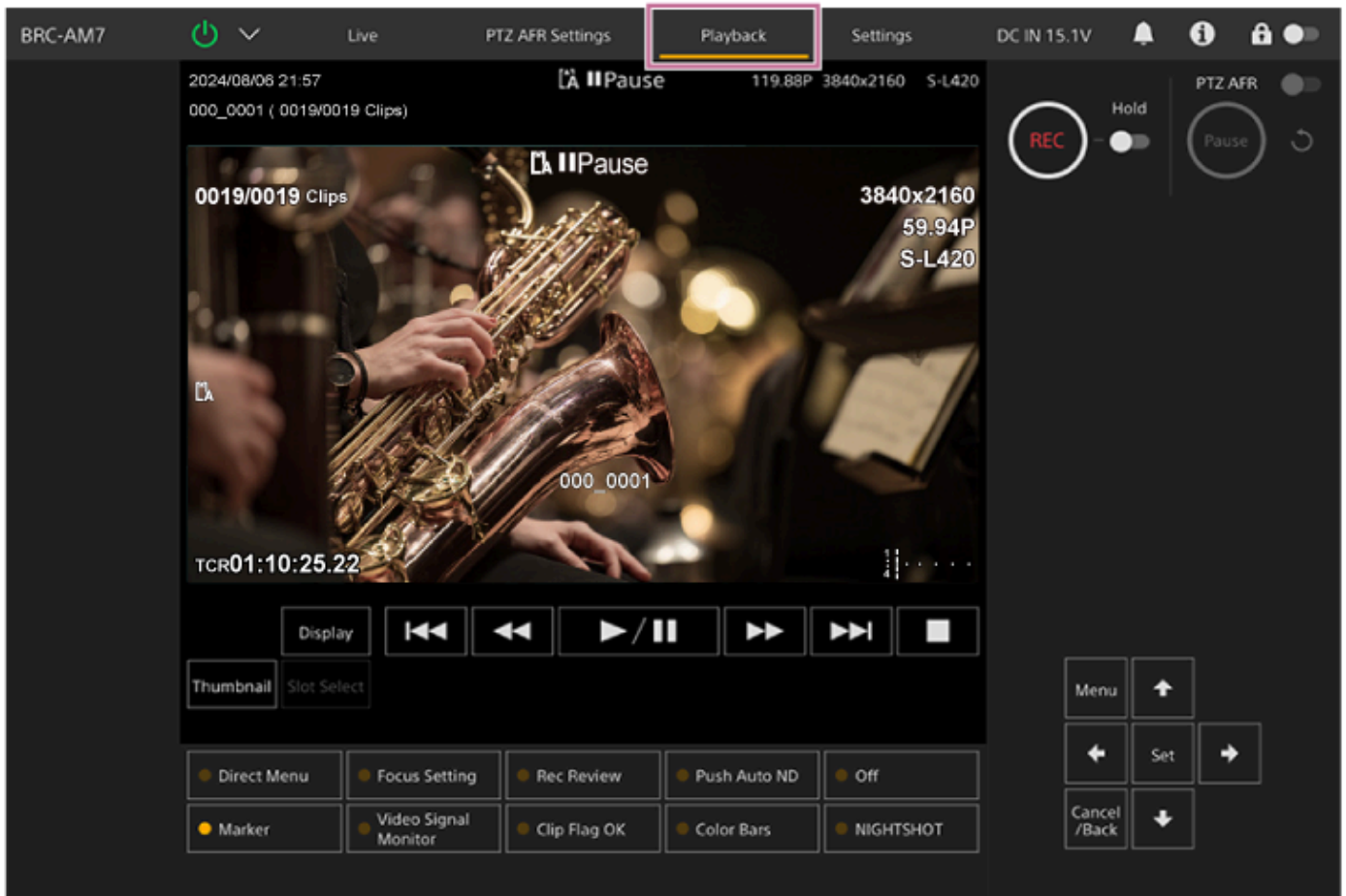

- For details about the playback operation screen, see “Structure of the Playback Operation Screen.”

Settings screen

Press the [Settings] tab to display the settings screen (hereinafter referred to as the web menu).

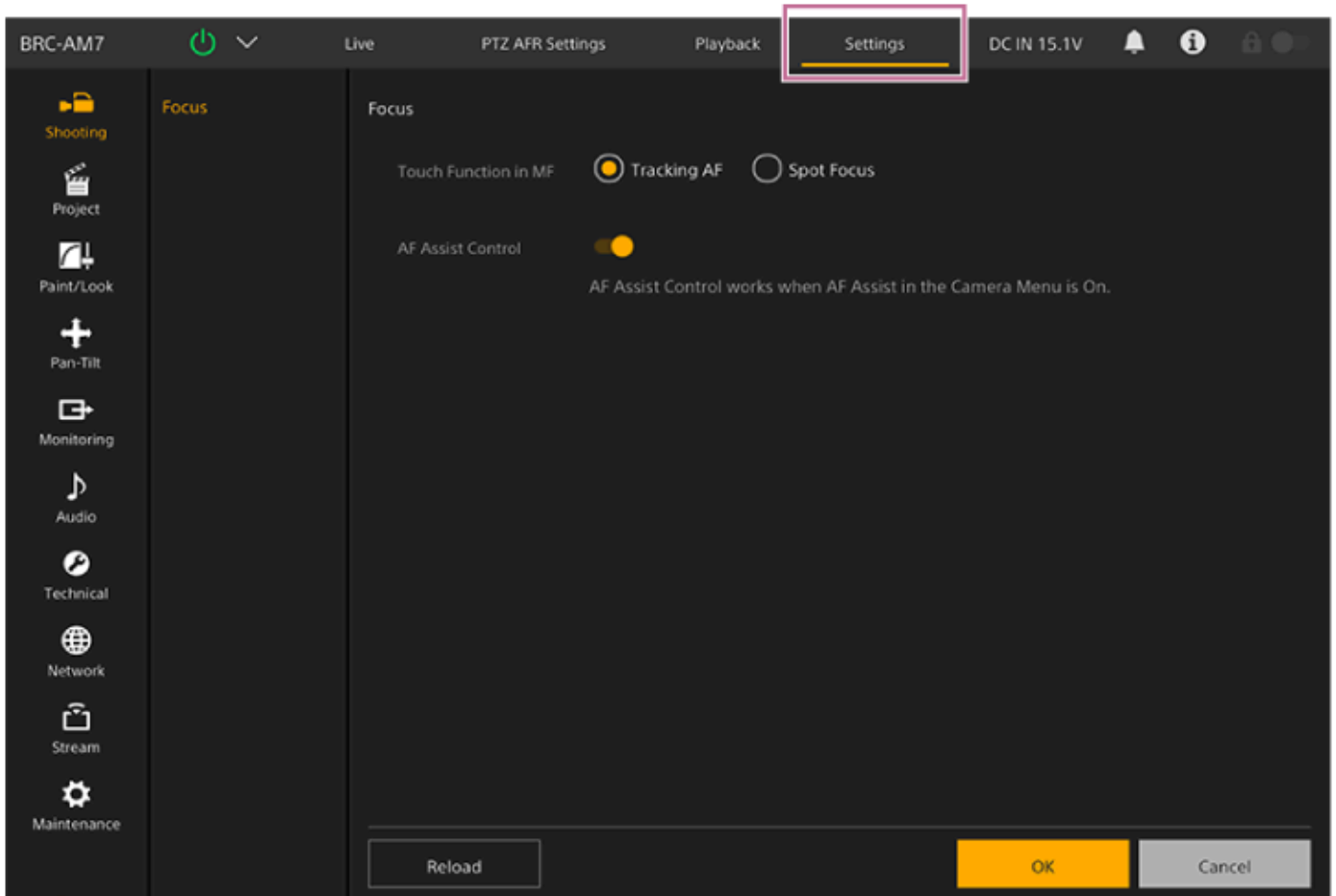

- For details about the settings screen, see “Structure of the Settings Screen.”
- In this Help Guide, the settings screen of the Web App is referred to as the web menu.

Note

- In the web menu, settings are not applied until you press the [OK] button. If you change settings on a page that has an [OK] button, be sure to press the [OK] button.

Related Topic

- [Accessing the Web App from a Web Browser](#)
- [Structure of the Live Operation Screen](#)
- [Structure of Common Area of Screens](#)
- [Structure of the PTZ AFR Settings Screen](#)
- [Configuring PTZ Auto Framing Initial Settings](#)
- [Structure of the Playback Operation Screen](#)
- [Structure of the Settings Screen](#)

TP1001804460

Structure of Common Area of Screens

This topic describes the structure of the common area of screens.



1. Camera name

Displays the name of the camera.

You can change the name using [Network] – [Camera Name] in the web menu.

The background color changes according to the external tally signal.

2. Power switch

When the unit is turned on, a check mark is placed in [Power ON] in the switch menu.

You can press the power switch and select [Power Standby] in the switch menu to set the power supply of the unit to standby state.

In power standby mode, the following screen appears.



To turn the power on again, press the power switch and select [Power ON] in the switch menu.

3. Operation screen switching tabs

Press a tab to display the corresponding operation screen.

[Live] tab: Displays the live operation screen.

[PTZ AFR Settings] tab: Displays the screen used to configure the PTZ auto framing initial settings.

[Playback] tab: Displays the playback operation screen.

[Settings] tab: Displays the settings screen (web menu).

4. DC IN voltage and abnormal temperature warning

Displays the DC IN voltage value. If an abnormal temperature condition arises, the  (Temperature warning) mark appears.

5. Notifications mark

When a message arrives, the mark indication changes as shown below.

 (Notifications On)

Take the necessary action according to the message displayed in the camera image panel.

Note

- Messages are not displayed when [Monitoring] – [Output Display] – [SDI2/HDMI/Stream] is set to off in the web menu. Set to on to check the contents of messages.

6.  (Camera Status) button

Press the button to display camera recorded image/output image signal information status on a separate screen.

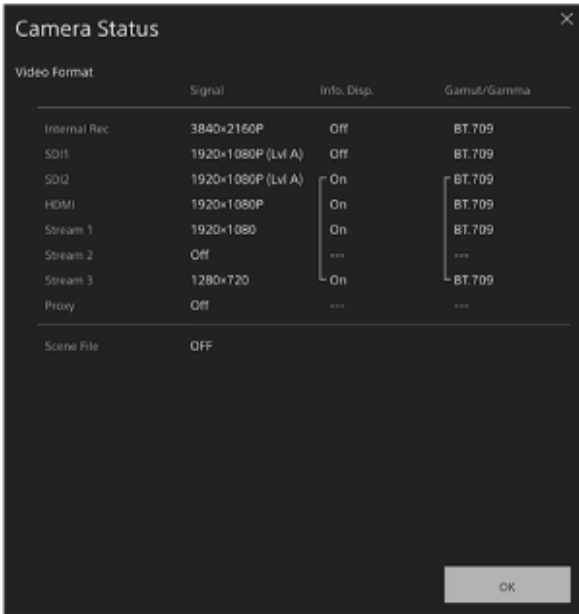

7. Screen operation lock switch

 (Operation Unlock): Set the switch to the left position to perform live operation screen and playback operation screen operations.

 (Operation Lock): Set the switch to the right position to lock the live operation screen and playback operation screen to prevent accidental operation.

TP1001804461

Structure of the Live Operation Screen

This topic describes the structure of the live operation screen.

When PTZ auto framing is off



When PTZ auto framing is on



1. Preset position control panel

Displays the registered position of a preset using a thumbnail. Double-tap the thumbnail to return to the position stored in the preset.

- For details about preset position, see “Saving/Restoring Pan/Tilt, Zoom Position, and Focus Setting Using the Web App.”

2. Camera image panel

Displays the current camera image and the status of the unit.

It displays the same image as the HDMI output.

The following status is displayed above the image. Also displays a red, green, or yellow frame around the image according to the received external tally signal.

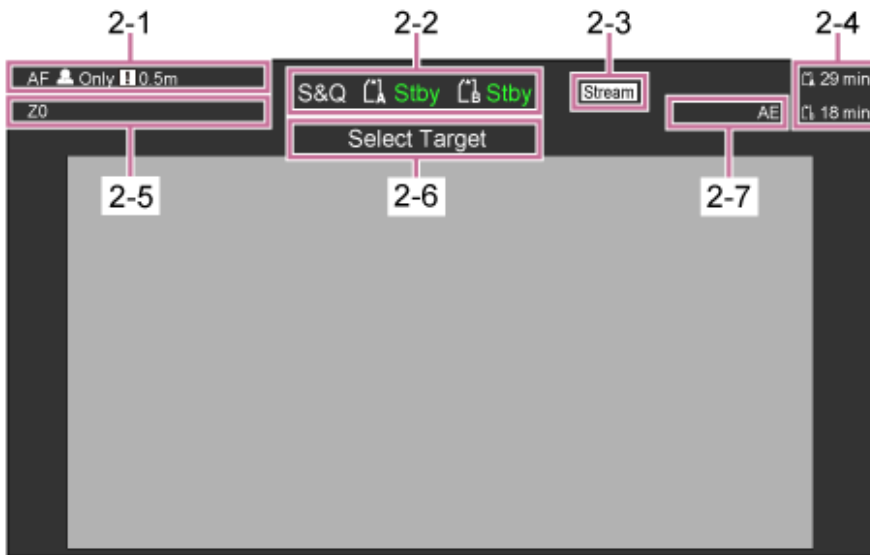

No.	Display	Description
2-1	Focus mode indicator	See “Focus mode indicator” in “Camera Screen Display.”
2-2	Recording mode, slot A/B, operating status indicator	See “Recording mode, slot A/B, operating status indicator” in “Camera Screen Display.”
2-3	Streaming status indicator	Displayed during streaming (when [Stream Setting] is set to [RTMP] or [SRT-Caller] only).
2-4	Remaining media capacity indicator	See “Remaining media capacity indicator” in “Camera Screen Display.”
2-5	Zoom position indicator	See “Zoom position indicator” in “Camera Screen Display.”
2-6	PTZ auto framing status indicator	Displayed when PTZ auto framing is enabled.
2-7	AE mode/AE level indicator	See “AE mode/AE level indicator” in “Camera Screen Display.”

[Display] button

Press this button to display camera information on the image.

Press again while the camera information is displayed to hide the camera information.



In addition to markers, some auto focus-related indicators and messages are displayed according to the status, and these cannot be hidden by pressing the [Display] button.

- For details about the displayed camera information, see “Camera Screen Display.”

Realtime tracking AF stop button

Press the button to stop tracking a subject.



- For details, see “Tracking a Specified Subject (Realtime Tracking AF).”

3. Record START/STOP button

Press the button to start recording. During recording, the record START/STOP button lights up red.
 Press during recording to stop recording.
 You can set the Hold switch to the Hold state to prevent misoperation of the record START/STOP button.

4. PTZ AFR control panel

PTZ auto framing is enabled when the PTZ AFR switch is set to the on position. Tap a person to track in the camera image panel.
 You can also set the camera to automatically track a person who appears in a specific position on the PTZ AFR setup screen beforehand. For details, see “Configuring PTZ Auto Framing Initial Settings.”
 During tracking, the area around the [Pause] button lights up blue.
 A blinking blue light indicates that operator intervention is required. Check the message displayed in the camera control panel and take the required action.

5. Composition preset control panel

Displays the registered framing composition presets as thumbnails. Double-tap a thumbnail to return to the framing stored in the preset.
 Displayed when PTZ auto framing is enabled.

6. Camera basic configuration panel

Displays settings for basic functions required for shooting on buttons. Press a button to display the corresponding setup screen for each function in the camera basic configuration adjustment panel below (7).

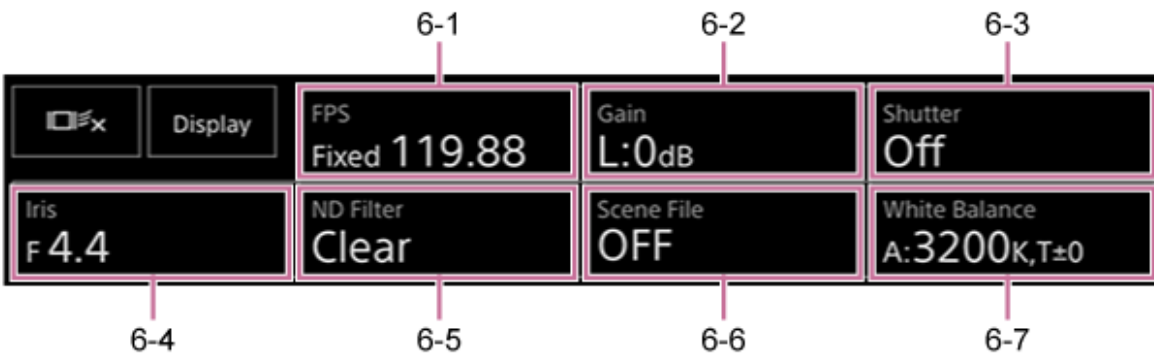

- 6-1 [FPS]
- 6-2 [ISO/Gain]
- 6-3 [Shutter]
- 6-4 [Iris]
- 6-5 [ND Filter]
- 6-6 [Scene File / Base Look/LUT]
- 6-7 [White Balance]

- For details, refer to the description of each function.

Function	Reference
[FPS]	“Slow & Quick Motion”
[ISO/Gain]	“Adjusting the Gain Automatically” and “Adjusting the Gain Manually” in “Adjusting the Gain”
[Shutter]	“Adjusting the Shutter Automatically” and “Adjusting the Shutter Manually” in “Adjusting the Shutter”

Function	Reference
[Iris]	“Adjusting the Iris Automatically” and “Adjusting the Iris Manually” in “Adjusting the Iris”
[ND Filter]	“About the ND Filter” in “Adjusting the Light Level (ND Filter)”
[Scene File]	“Look Overview” and other topics in “Shooting with the Desired Look”
[Base Look/LUT]	“Shooting with Look Adjustment in Post-Production”
[White Balance]	“White Balance Adjustment Screen”

7. Assignable buttons/Camera basic configuration adjustment panel

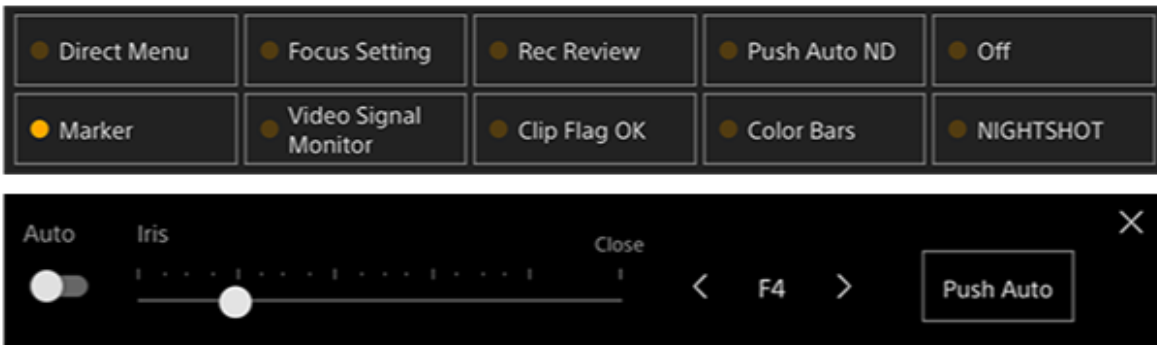

Displays assignable buttons during normal operation. Press the camera basic configuration panel buttons (item 6) to display the corresponding setup items. Press the [X] button or press the camera setup panel button again to return to the assignable button display.



- For details about assignable buttons, see “Assignable Buttons.”
- For details about the camera basic configuration adjustment panel, refer to the description of each function.

8. Framing control panel / GUI control panel / AFR composition adjustment panel

Switch between the framing control panel, GUI control panel, and AFR composition adjustment panel using the tabs at the top.

You can press the  (Close) button at the top right of the screen to hide the control panel to prevent inadvertent operation. If the control panel is not displayed, press the  (Open) button to display it.

Use the framing control panel to adjust the framing. Press the  (Pan/tilt/zoom) tab to display the framing control panel.

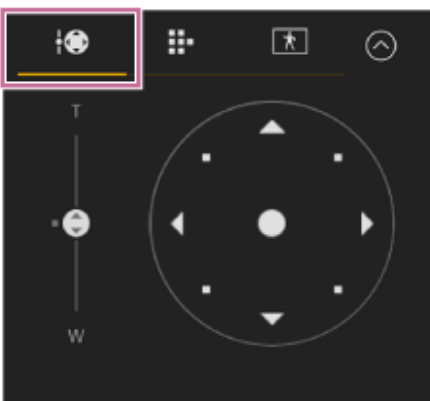

- For details about operation, see “Adjusting the Framing.”

Hint

- The joystick part of the framing control panel is displayed as shown below when pan/tilt operation is disabled and when pan/tilt initialization is required.
 - When pan/tilt operation is not initialized

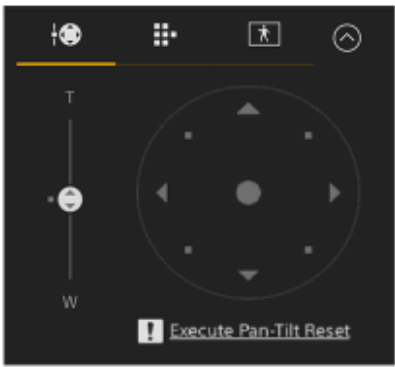

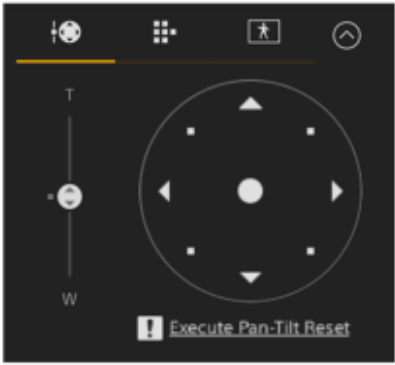

— When pan/tilt operation needs to be reset

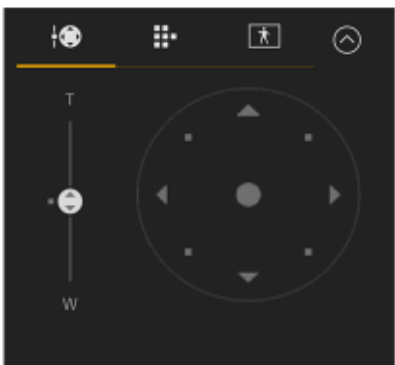

— When pan/tilt operation is disabled



- When pan/tilt operation is not initialized or needs to be reset, you can quickly access the  (Pan/tilt reset) button in the camera control panel by pressing the message displayed below the joystick.

Use the GUI control panel to operate the camera menu, clip playback, and other functions. Press the  (Cam GUI) tab to display the GUI control panel.

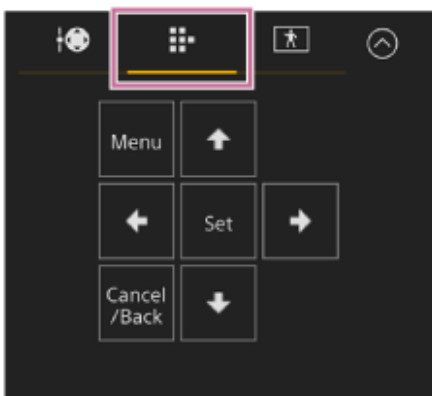

- For details about operation, see “Operating the Camera Menu” and “Playing Recorded Clips.”

Use the AFR composition adjustment panel to adjust the composition for PTZ auto framing. Press the  (AFR composition adjustment) tab to display the AFR composition adjustment panel.

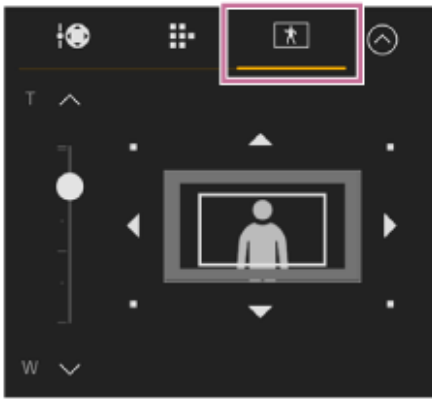



For operation, see “Specifying the Subjects for Automatic Tracking (manual tracking start mode).”

9. Camera control panel

Use to configure the functions required to operate the camera.

Switch between the screens to display using the tabs at the top.

You can press the  (Close) button at the top right of the screen to hide the control panel to prevent inadvertent operation. If the control panel is not displayed, press the  (Open) button to display it.

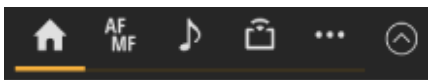

- For details, see the description of each function.

(Main) tab

Displays the setup items for frequently used functions.

The top and bottom slider functions can be changed by pressing the  button and selecting from the displayed list. The following functions can be selected.

- [ND Filter]
- [Iris]
- [ISO]*
- [Gain]*
- [AE Level]
- [Zoom Speed]
- [Pan-Tilt Speed]

* Displayed according to menu settings.

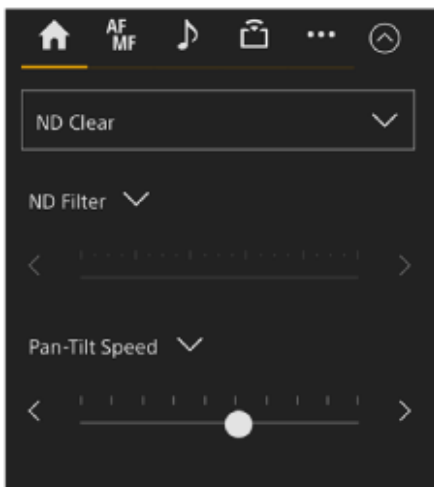

(Focus) tab

Displays the setup items related to focus.

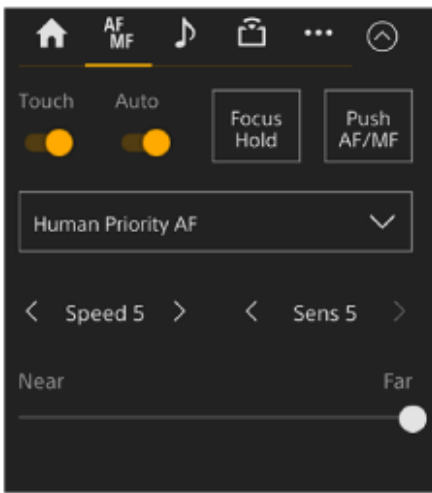

(Audio) tab

Displays the setup items related to audio.

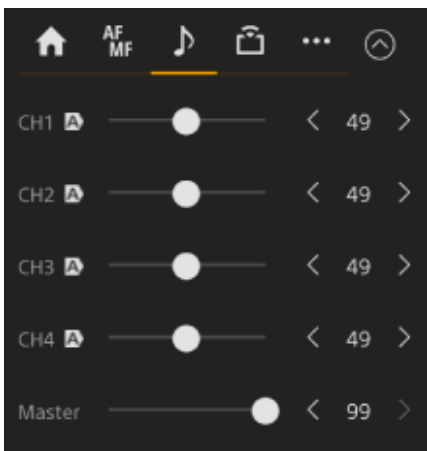

(Stream) tab

Displays the setup items related to streaming.

The items displayed will vary depending on the streaming format setting.

When set to [RTMP] or [SRT-Caller], streaming can be started/stopped on this screen.

- For details, see “About Streaming” and other topics in “Configuring Streaming.”
- Error information is displayed if a connection failure occurs. For details about error information, see “Error/Warning Messages.”

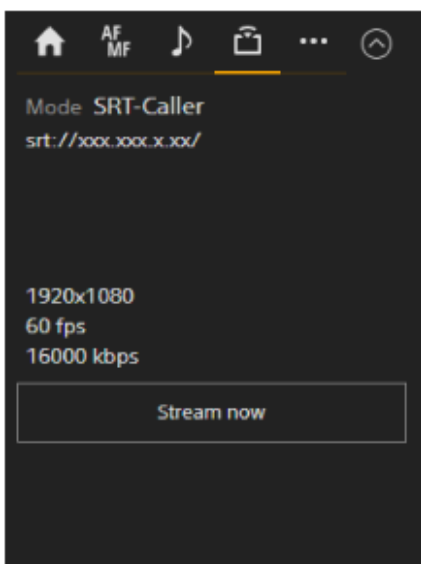

(Others) tab

Displays the setup items related to other functions.

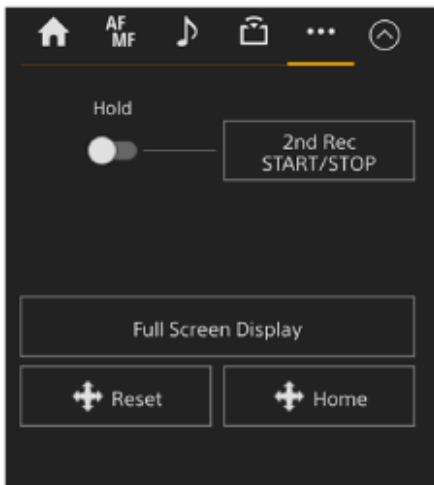

Pressing the [Full Screen Display] button opens a new tab in the web browser and displays the camera image panel image in full screen.

Only image display occurs; touch AF and other functions are not available.

Note

- The live operation screen on the original tab continues to function. It is recommended that you close the tab to reduce the number of simultaneous connections if no operation is required.

Related Topic

- [Saving/Restoring Pan/Tilt, Zoom Position, and Focus Setting Using the Web App](#)
- [Configuring PTZ Auto Framing Initial Settings](#)
- [Specifying the Subjects for Automatic Tracking \(manual tracking start mode\)](#)
- [Camera Screen Display](#)
- [AF Tracking a Specified Subject \(Realtime Tracking AF\)](#)
- [Slow & Quick Motion](#)
- [Adjusting the Gain Automatically](#)
- [Adjusting the Gain Manually](#)
- [Adjusting the Shutter Automatically](#)
- [Adjusting the Shutter Manually](#)
- [Adjusting the Iris Automatically](#)
- [Adjusting the Iris Manually](#)
- [About PTZ Auto Framing](#)
- [About the ND Filter](#)
- [Look Overview](#)
- [Shooting with Look Adjustment in Post-Production](#)
- [White Balance Adjustment Screen](#)
- [Assignable Buttons](#)
- [Playing Recorded Clips](#)
- [Operating the Camera Menu](#)
- [About Streaming](#)
- [Error/Warning Messages](#)

Structure of the PTZ AFR Settings Screen

This screen is used to configure the PTZ auto framing initial settings.

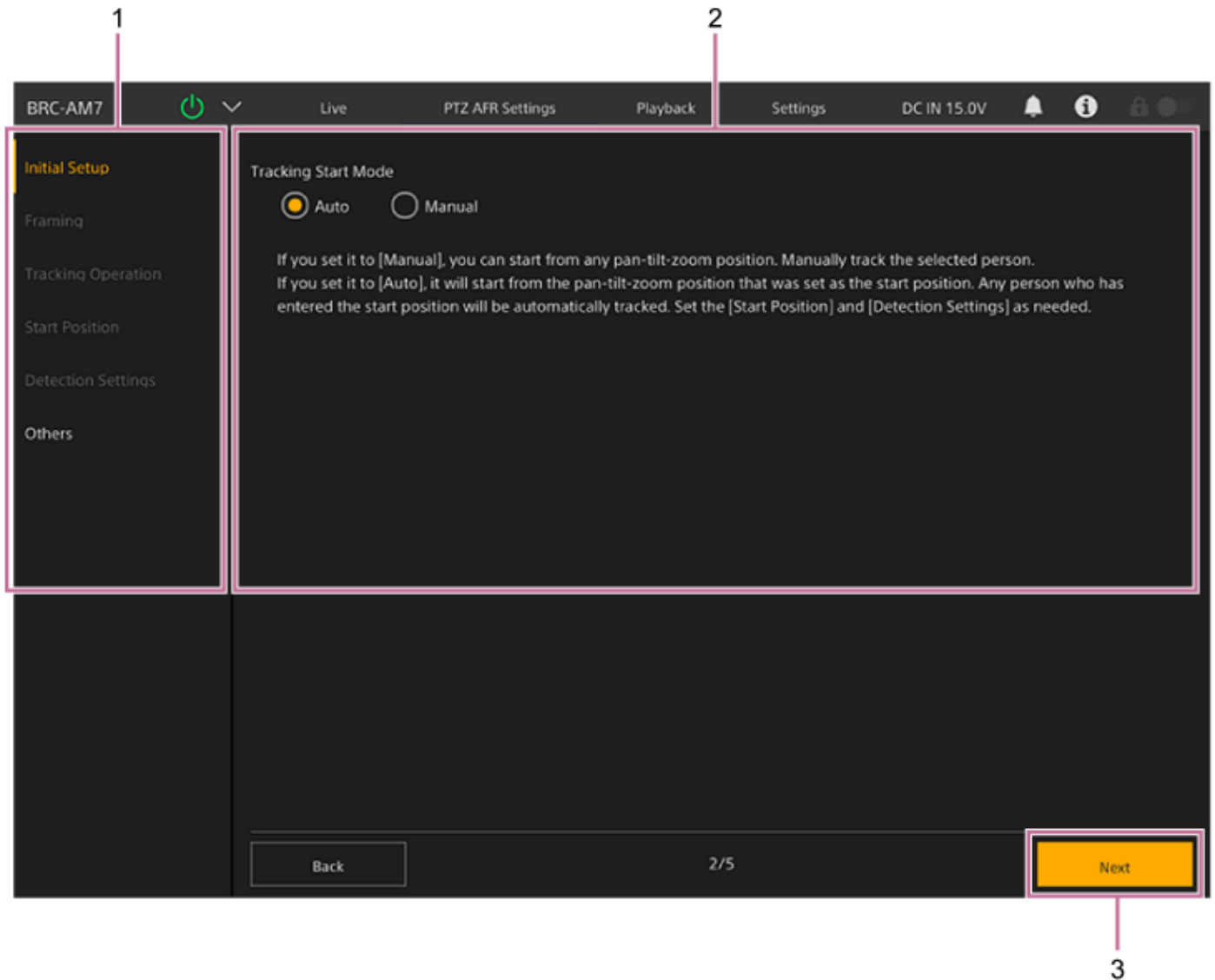

1. Setup item tabs

Displays the setup items. When configuring PTZ auto framing initial settings, only [Initial Setup] and [Others] can be selected. After the initial settings are completed, they can be set individually.

2. Settings screen

Displays the settings screen and configuration guidance.

3. [Start] button

Displayed only when configuring PTZ auto framing settings for the first time.

Press the [Start] button to start configuring PTZ auto framing settings. Follow the on-screen guidance to configure each setup item in order.

For details, see “Configuring PTZ Auto Framing Initial Settings.”

Structure of the Playback Operation Screen

This topic describes the structure of the playback operation screen.



1. Camera image panel

Displays the playback image and related information. When playback is stopped, the camera image screen appears.

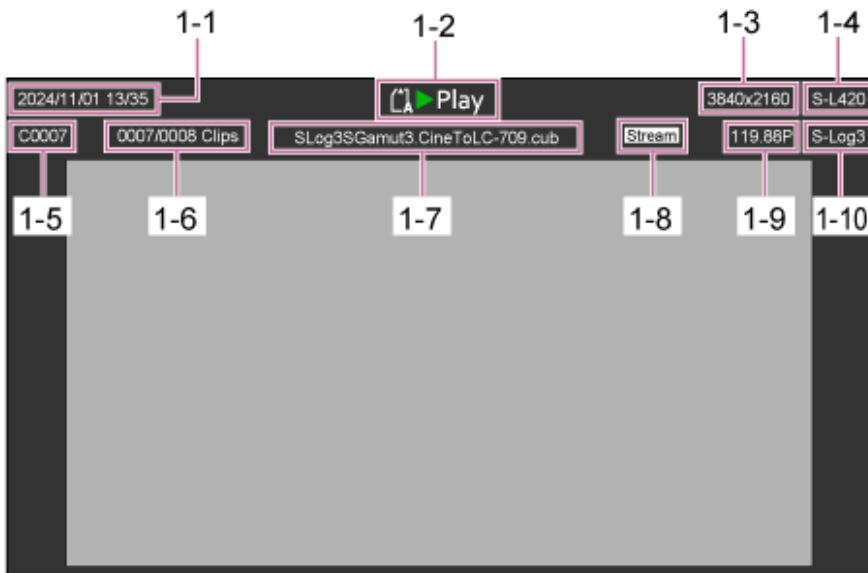

- 1-1 Shooting date and time
- 1-2 Playback status indicator
- 1-3 Playback format (picture size) indicator
- 1-4 Playback format (codec) indicator
- 1-5 Clip name display
- 1-6 Clip number/total number of clips
- 1-7 LUT name display
- 1-8 Streaming status indicator
- 1-9 Playback format (frame rate and scan method) indicator
- 1-10 Recording look indicator

2. Playback control panel



Displays the playback control buttons.

Button	Function
(Play/Pause) button	Plays a clip. During playback, pauses the clip.
(Fast Forward) button, (Fast Reverse) button	Plays a clip at high speed. When the button is pressed, the playback speed changes in three steps.
(Next) button, (Previous) button	Jumps to start of clip or the previous/next clip.
(Stop) button	Stops playback.

[Display] button

Press to switch between the screen display on the image.

[Thumbnail] button

Displays the clips recorded on the memory card on the camera image panel as thumbnails.

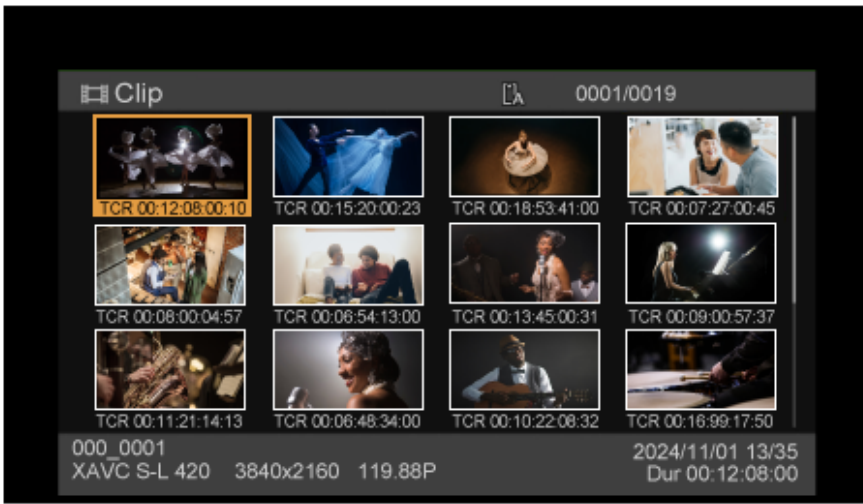

Pressing the [Thumbnail] button during thumbnail screen display closes the thumbnail screen and returns to the camera image.

- For details about the thumbnail screen, see “Thumbnail Screen.”

[Slot Select] button

Switches between the target playback media.

3. Assignable buttons

Displays the assignable buttons assigned to functions of the unit.

- For details about assignable buttons, see “Assignable Buttons.”

4. GUI control panel

Use the GUI control panel to operate the camera menu, clip playback, and other functions.



- For details about operation, see “Operating the Camera Menu” and “Playing Recorded Clips.”

Related Topic

- [Thumbnail Screen](#)
- [Assignable Buttons](#)
- [Playing Recorded Clips](#)

TP1001804464

Color Video Camera
BRC-AM7

Structure of the Settings Screen

Use the settings screen to configure the various setup items of the unit, including initial settings, network settings, shooting/playback settings using the web menu.

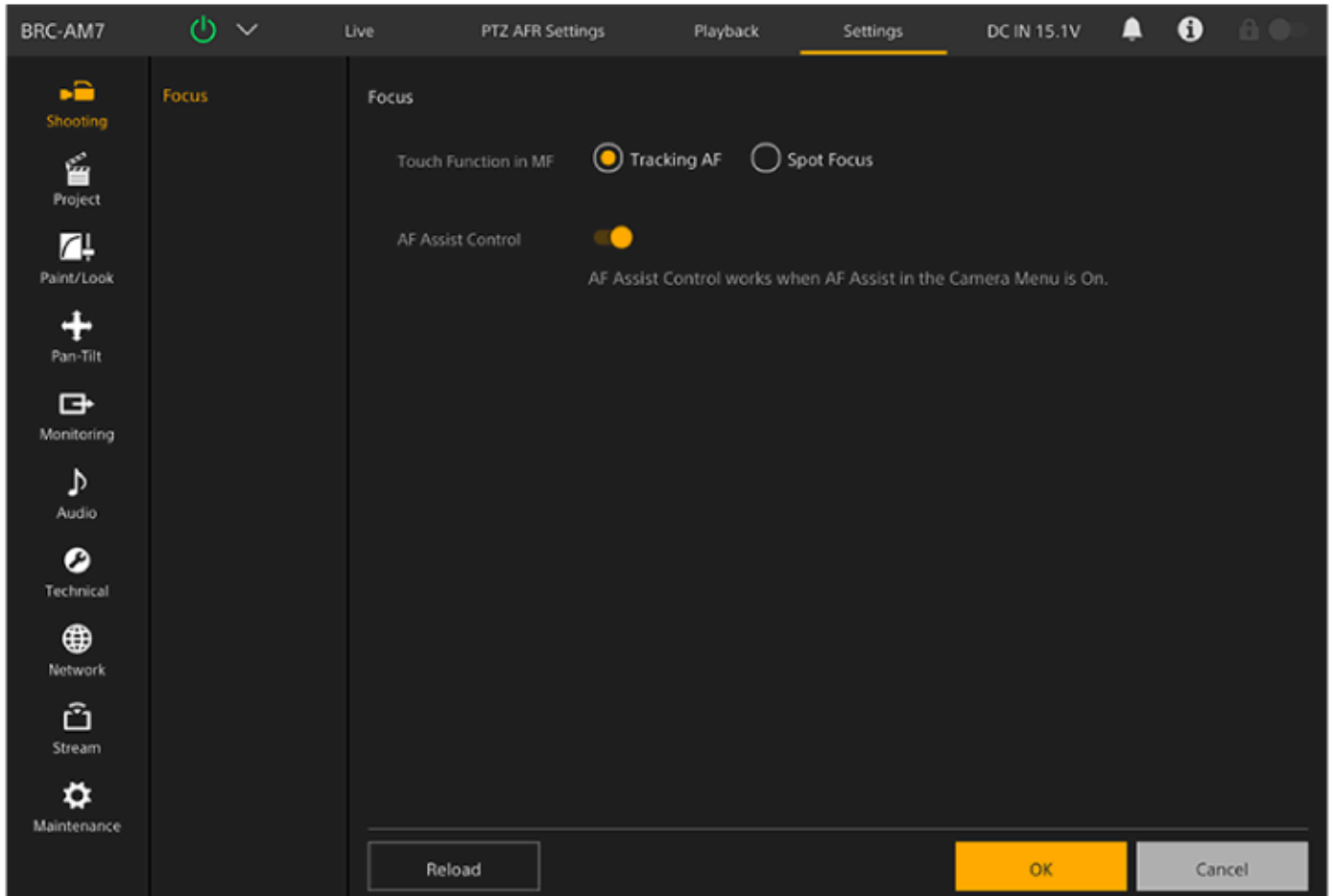

Note

- In the web menu, settings are not applied until you press the [OK] button as a general rule. If you change settings on a page that has an [OK] button, be sure to press the [OK] button.
- For details about the settings screen, see “Web Menu Configuration.”

Related Topic

- [Web Menu Configuration](#)

TP1001804465

Camera Menu

Press the [Menu] button in the GUI control panel of the live operation screen or playback operation screen to display the camera menu in the camera image panel.

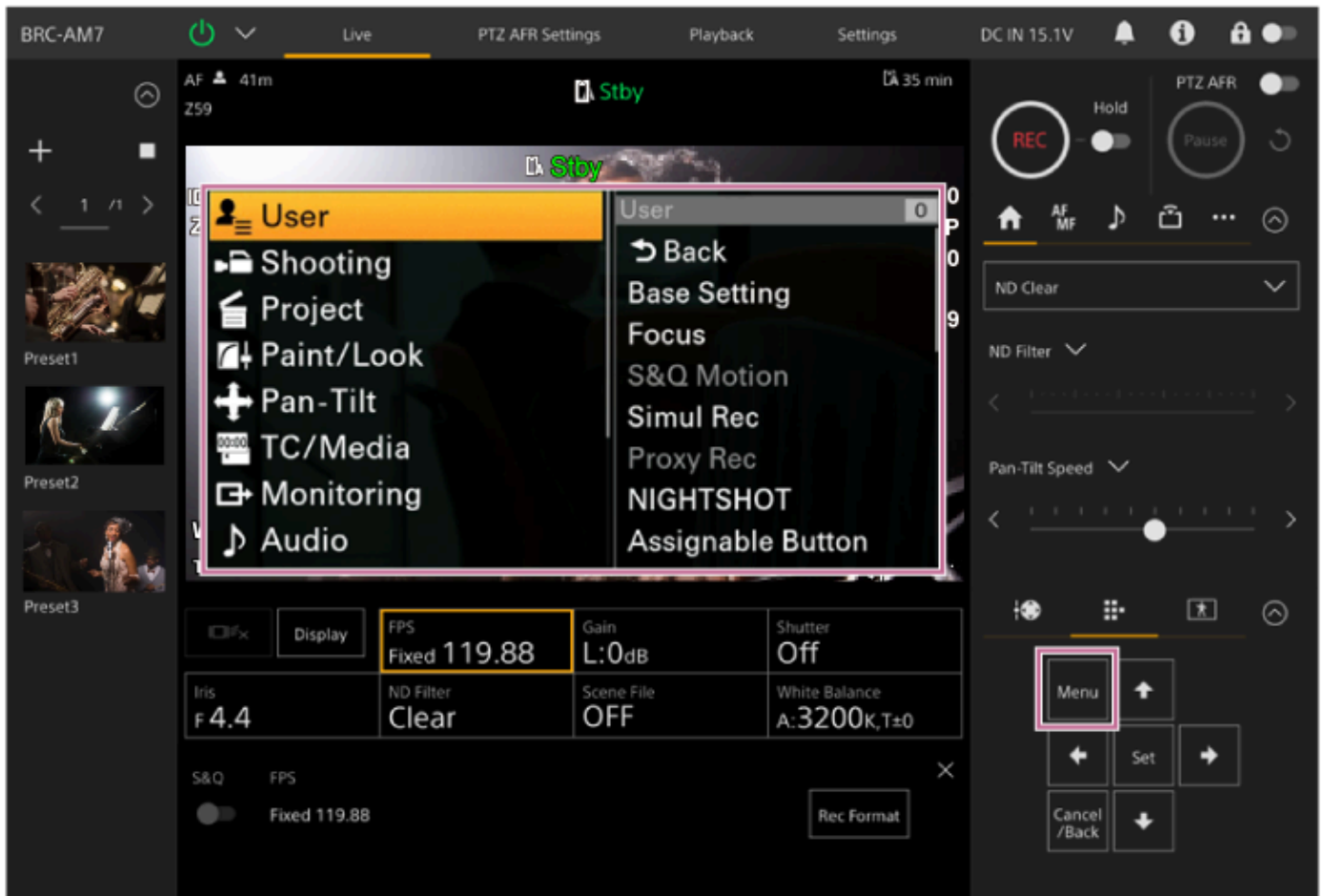

You can configure the settings required for shooting and playback using the camera menu. Press the [Menu] button while the camera menu is displayed to hide the camera menu. The camera menu is operated using the GUI control panel.

- For details about the camera menu, see “Web Menu Configuration.”

Note

- When [Monitoring] – [Output Display] – [SDI2/HDMI/Stream] is set to off in the web menu (disables information overlay on the screen display), the camera menu is no longer displayed in the camera image panel. However, be aware that menu operations in the GUI control panel are still active. To avoid inadvertent operation, take care to not perform any menu operations using the GUI control panel when [SDI2/HDMI/Stream] is set to off.

Related Topic

- [Camera Menu Configuration](#)

Camera Screen Display

You can display the status and settings of the unit superimposed on the output image from the camera. You can set the output to overlay on the screen display using [Monitoring] – [Output Display] in the web menu.

You can show/hide the information using the [Display] button. Even when hidden, it will appear while performing direct menu operations.

You can show/hide items individually using [Monitoring] – [Display On/Off] in the camera menu.

Information displayed on the screen while shooting

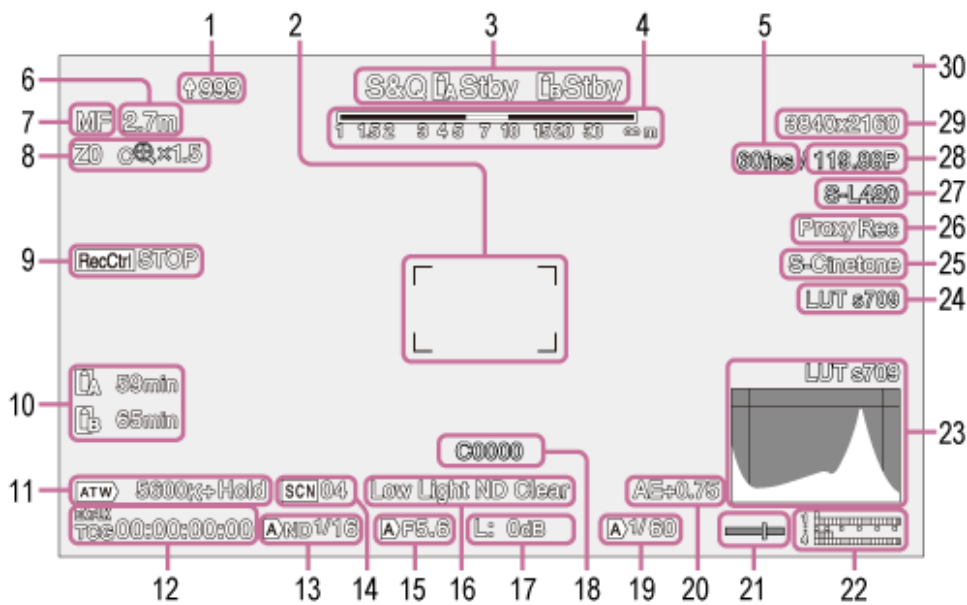

1. Upload indicator/remaining files indicator

- For details about transferring files, see “About File Transfer” and other topics in “Transferring Files.”

2. Focus area indicator

Displays the focus area for auto focus.

- For details about auto focus, see “Adjusting the Focus Automatically Using the Web App” and other topics in “Adjusting the Focus Automatically (Auto Focus).”

3. Recording mode, slot A/B, operating status indicator

Display	Meaning
●Rec	Recording
Stby	Recording standby

4. Depth-of-field indicator

5. Slow & Quick Motion shooting frame rate indicator

- For details about Slow & Quick Motion, see “Slow & Quick Motion.”





6. Focus position indicator

- Displays the focus position.

7. Focus mode indicator

Display	Meaning
Focus Hold	Focus Hold mode
MF	MF mode
AF	AF mode
 (Realtime tracking AF mode)	Realtime tracking AF mode

Subject recognition AF

Display	Meaning
 (Human detection AF icon)	Indicates human detection AF is active
 Only (Human only detection AF icon)	Indicates human only detection AF is active
 (PTZ AFR AF icon)	Indicates PTZ auto framing is active
	Indicates a tracking face has been saved
 (AF paused icon)	Indicates that AF was paused [*]

* Displayed when there is no saved tracking face and a face is not detected, or when there is a saved tracking face but the tracking target face is not detected.

- For details about subject recognition AF, see “Detecting and AF Tracking a Person.”

8. Zoom position indicator

Displays the zoom position in the range 0 (wide angle) to 99 (telephoto).

You can also change the indicator to a bar display or focal length display using the [Technical] – [Lens] – [Zoom Position Display] setting in the camera menu.

The following items are added to the display when Clear Image Zoom is enabled.

Display	Meaning
 (Clear Image Zoom enabled)	Clear Image Zoom is enabled
Magnification value	When using Clear Image Zoom

- For details about zoom, see “Setting the Zoom Type” and other topics in “Adjusting the Zoom.”

9. SDI output/HDMI output Rec Control status indicator



Displays the output status of the REC control signal.

- For details, see “Connecting External Monitors and Recording Devices.”

10. Remaining media capacity indicator

A  (Protected) icon appears if the memory card is write-protected.

11. White balance indicator

Display	Meaning
 (ATW)	Auto mode
 Hold (ATW Hold)	Auto mode paused
W:P	Preset mode
W:A	Memory A mode

12. Timecode external lock indicator/time data display

Displays “EXT-LK” when locked to the timecode of an external device.

- For details about timecode, see “Specifying Time Data.”

13. ND filter indicator

Display	Meaning
 (A)	Auto mode

- For details about ND filters, see “Adjusting the Light Level (ND Filter).”

14. Scene file indicator

- For details about scene files, see “Look Overview” and other topics in “Shooting with the Desired Look.”



15. Iris indicator

Displays the iris position (F-number).

- For details about the iris, see “Adjusting the Iris Automatically” and “Adjusting the Iris Manually.”

16. Video level warning indicator

17. Gain indicator

Display	Meaning
 (A)	Auto mode
L	Preset L mode
 (Temporary adjustment mode)	Temporary adjustment mode

- For details about the gain, see “Adjusting the Gain Automatically” and “Adjusting the Gain Manually.”

18. Clip name display

Displays the name of the clip being recorded or to record next.

19. Shutter indicator

- For details about the shutter, see “Adjusting the Shutter Automatically” and “Adjusting the Shutter Manually.”

20. AE mode/AE level indicator

- For details about auto exposure (AE), see “Setting the Target Level for Automatic Brightness Adjustment.”

21. Spirit level indicator

Displays the horizontal tilt of the camera head of the unit in $\pm 1^\circ$ increments up to $\pm 15^\circ$.

22. Audio level meter

Displays the audio level of each channel.

23. Video signal monitor

Displays a waveform, vectorscope, and histogram.

The orange line indicates the set value of the brightness level marker.

In log shooting mode, the monitor target LUT type is displayed above the display.

- For details, see “Video Signal Monitor.”
- For details about log shooting mode, see “Setting the shooting mode” in “Configuring Basic Operation.”

24. Monitoring look indicator

In log shooting mode, it displays the monitor LUT setting.

- For details about the LUT setting, see “Shooting with Look Adjustment in Post-Production” and related topics.
- For details about log shooting mode, see “Setting the shooting mode” in “Configuring Basic Operation.”

25. Base look/recording look indicator

Displays the base look setting.

In log shooting mode, it displays the video signal to record on the memory cards.

- For details about the base look, see “Look Overview” in “Shooting with the Desired Look.”
- For details about log shooting mode, see “Setting the shooting mode” in “Configuring Basic Operation.”

26. Proxy status indicator

27. Recording format (codec) indicator

Displays the name of the format for recording on the memory cards.

Set the recording format (codec) using [Project] – [Rec Format] – [Codec] in the web menu or camera menu.

28. Recording format (frame rate and scan method) indicator

29. Recording format (picture size) indicator

Displays the picture size for recording on the memory cards.

Set the recording format (picture size) using [Project] – [Rec Format] – [Video Format] in the web menu or camera menu.

30. Tally indicator

Displays a red, green, or yellow frame around the image according to the received external tally signal.

Information displayed on the screen during playback

The following information is superimposed on the playback picture.

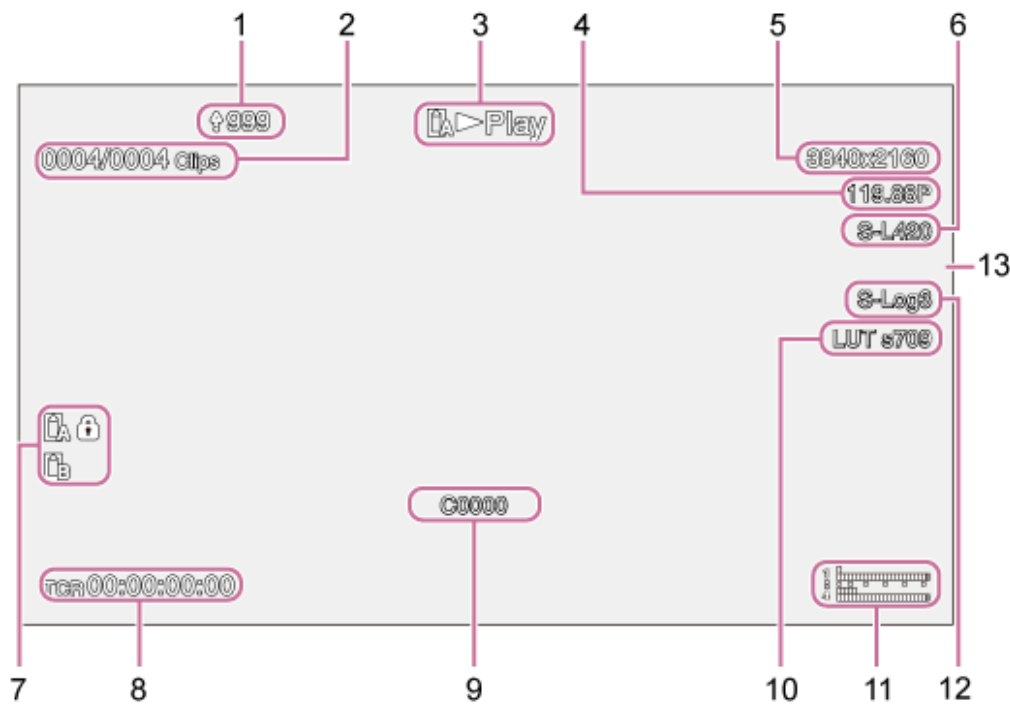

1. Upload indicator/remaining files indicator
2. Clip number
3. Playback status indicator
4. Playback format (frame rate and scan method) indicator
5. Playback format (picture size) indicator
6. Playback format (codec) indicator
7. Media indicator
A  (Protected) icon appears if the memory card is write-protected.
8. Time data display
9. Clip name display
10. Monitoring look indicator
11. Audio level meter
Displays the playback audio level.
12. Recording look indicator
13. Tally indicator

Related Topic

- [About File Transfer](#)
- [Adjusting the Focus Automatically Using the Web App](#)
- [Configuring Basic Operation](#)
- [Slow & Quick Motion](#)
- [Detecting and AF Tracking a Person](#)
- [Setting the Zoom Type](#)
- [Connecting External Monitors and Recording Devices](#)

- Specifying Time Data
- Look Overview
- Adjusting the Iris Automatically
- Adjusting the Iris Manually
- Adjusting the Gain Automatically
- Adjusting the Gain Manually
- Adjusting the Shutter Automatically
- Adjusting the Shutter Manually
- Setting the Target Level for Automatic Brightness Adjustment
- Video Signal Monitor
- Shooting with Look Adjustment in Post-Production
- [Clip Name Format]

TP1001804467

5-065-326-11(1) Copyright 2024 Sony Corporation

Color Video Camera
BRC-AM7

Mounting Upright in a Fixed Location

This topic describes mounting the unit on a desktop or tripod.

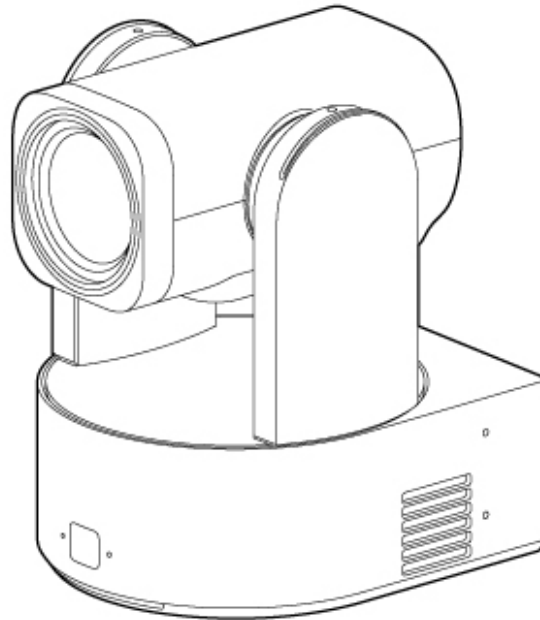

Installation note

- To prevent unit failure, do not hold the camera head while working.

1 Check the mounting space.

When mounting on a desktop

Mount this unit on a flat surface, taking into consideration the space required for turning the camera head and the wiring at the rear of the unit.

Note

- Mount it in a stable location that is not subject to vibration. Locations subject to vibration may cause vibration in the image.
- If the unit must be mounted on an inclined surface, keep it within $\pm 15^\circ$ of the horizontal and take measures to prevent the unit from falling.

When mounting on a tripod

Attach the tripod to the tripod mounting screw hole on the bottom.

Use a tripod mounting screw with the following amount of protrusion from the mounting surface, and tighten it with a hand screwdriver.

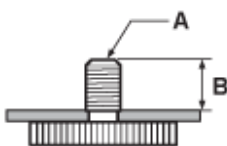

A: Tripod mounting screw 1/4-20 UNC screw or 3/8-16 UNC screw

B: Protrusion (4.5 mm to 5.5 mm)

WARNING

- Do not use tripod screws for mounting the unit in a high location.

TP1001804468

5-065-326-11(1) Copyright 2024 Sony Corporation

Color Video Camera
BRC-AM7

Mounting Upright in a High, Fixed Location

This topic describes how to mount the unit in a high location using the supplied ceiling bracket.

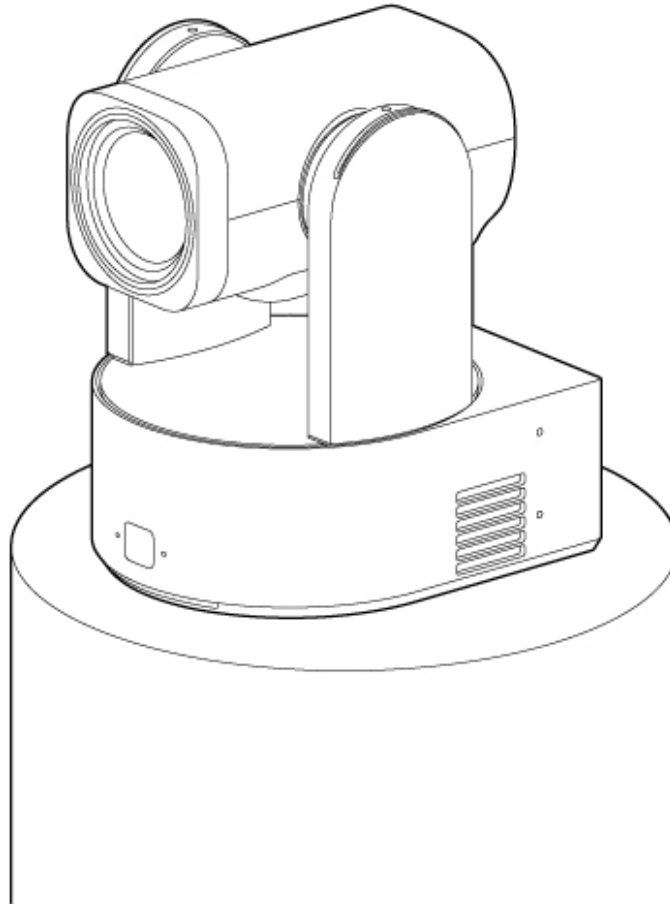

WARNING

- To mount the unit in a high location, ask a professional contractor.
- When mounting in a high location, make sure that the mounting surface and mounting material (excluding accessories) can support 200 kg (440 lb 15 oz) or more, and mount the unit as described in this Help Guide. If the mounting is not sturdy enough, the unit may fall and cause serious injury.
- Attach the supplied fall prevention wire rope to the unit to prevent the unit from falling.
- When the unit is mounted in a high location, check that the mounting has not become loose once a year. Shorten the inspection interval according to the usage conditions.

Installation note

- To prevent unit failure, do not hold the camera head while working.

1 Check the high-location mounting accessories and mounting space.

Before you start, check that you have the following parts.

- Ceiling bracket (A) (1)
- Ceiling bracket (B) (1)
- Fall prevention wire rope (1)
- +PSW M3×8 screws (6)
- +PSW M4×8 stainless steel screw for fall prevention wire rope (1)

Note

- The fall prevention wire rope is designed to support the unit when suspended. Do not apply any load to it other than the load of the unit.

Mounting space

Refer to the following drawing when determining the mounting location and direction, taking into consideration the space required for turning the lens and the wiring at the rear of the unit.

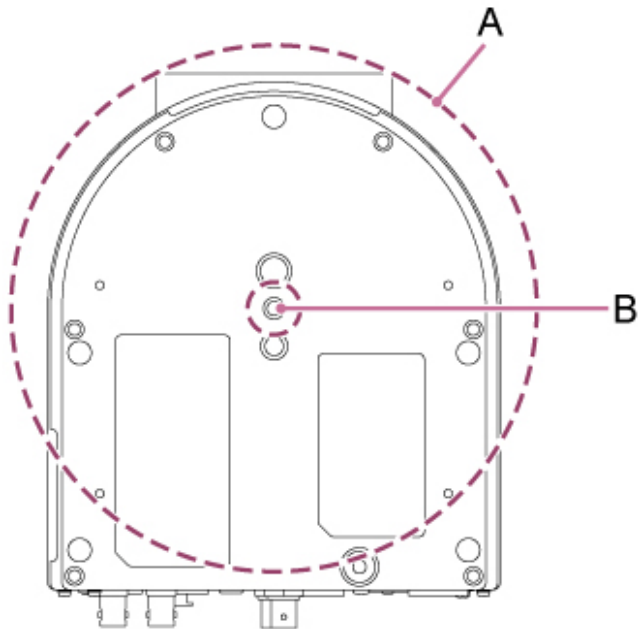

A: Camera head range of movement ($\varnothing 199$ mm)

B: Mounting wire rope feed hole ($\varnothing 20$ mm)

Note

- Mount it in a stable location that is not subject to vibration. Locations subject to vibration may cause vibration in the image.
- If the unit must be mounted on an inclined surface, keep it within $\pm 15^\circ$ of the horizontal and take measures to prevent the unit from falling.

2 Attach the ceiling bracket (A) to the bottom of the unit using the four supplied screws (M3×8).

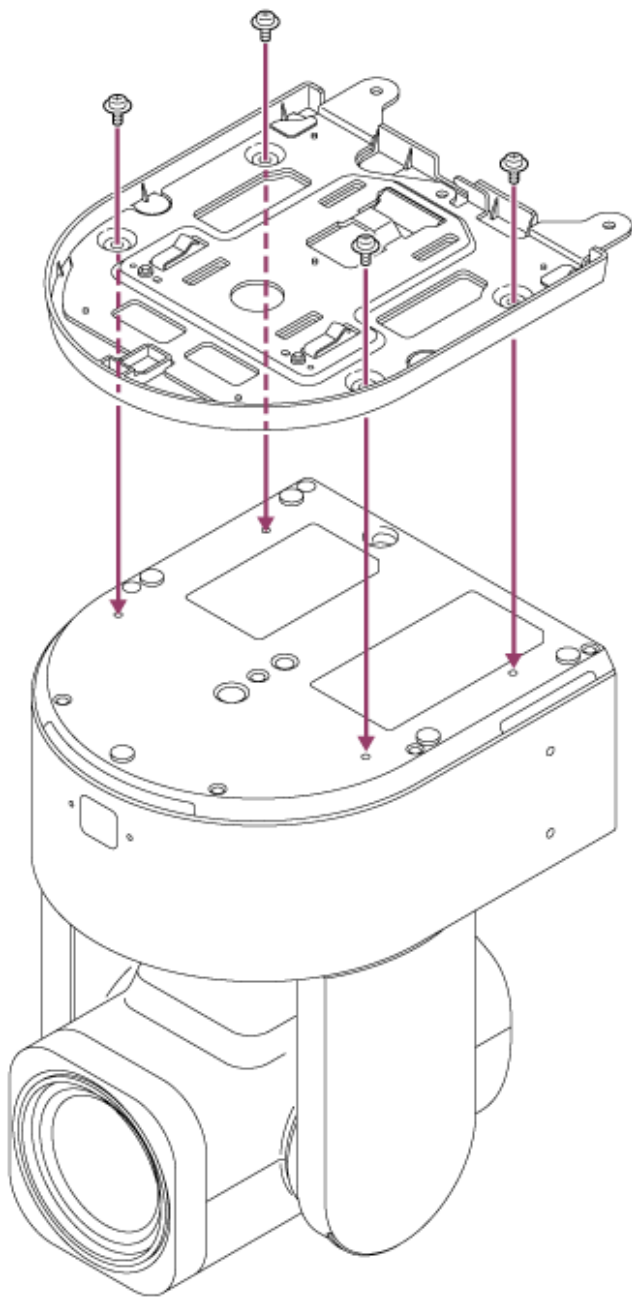

CAUTION

Use the supplied screws. The use of screws other than the supplied screws may damage the interior of the unit.

- 3 Route the fall prevention wire rope through the wire rope metal loop of the ceiling bracket (A) and attach it securely to the unit using the supplied screw (M4×8).

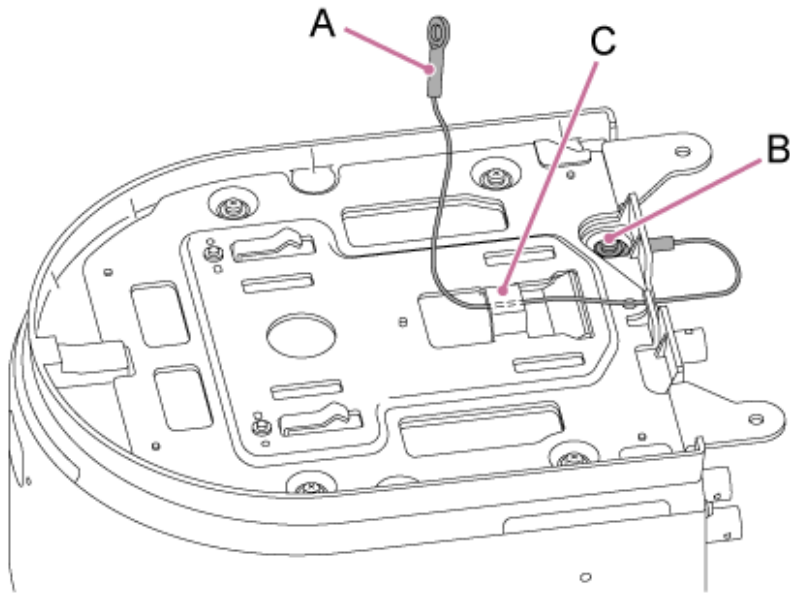

- A: Supplied wire rope
- B: Supplied screw (M4×8)
- C: Wire rope metal loop

WARNING

Use the supplied screw. The use of a screw other than the supplied screw may reduce the effectiveness of the wire rope function.

4 Attach the ceiling bracket (B) to the surface, such as a shelf, where the unit will be mounted.

Mounting screws are not supplied.

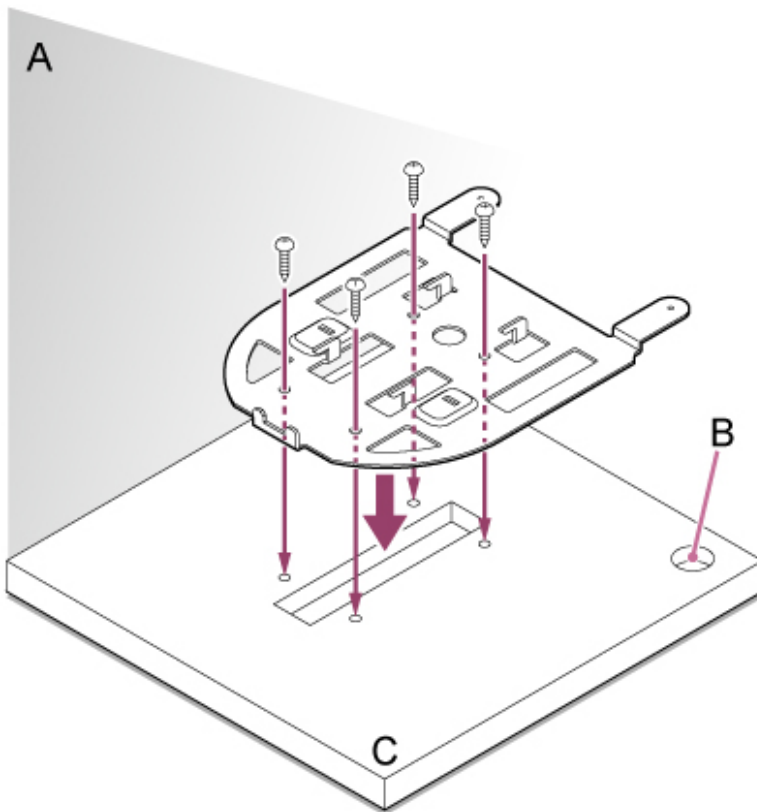

- A: Wall
- B: Hole for connection cables
- C: Shelf or other mounting surface

The arrow direction indicates the front of the camera. Adjust the camera orientation so that it faces forward.

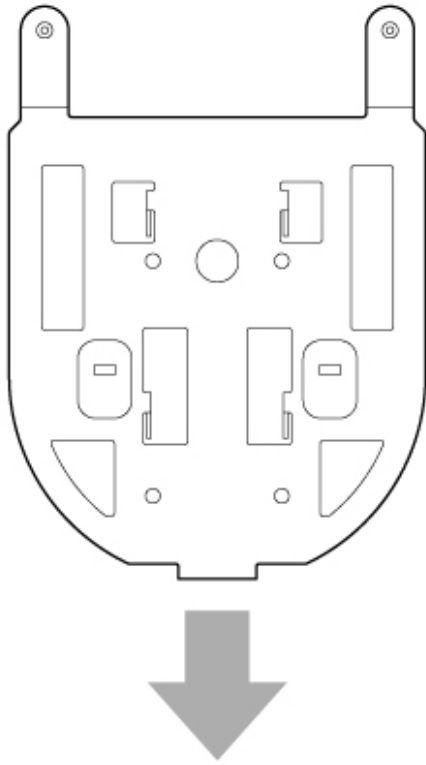

5 Attach the fall prevention wire rope to a point near the mounting surface.

Use an M5 (3/16 inch) hexagon socket head cap screw (option) and attach it to an object near the shelf or surface to which the ceiling bracket (B) is attached.

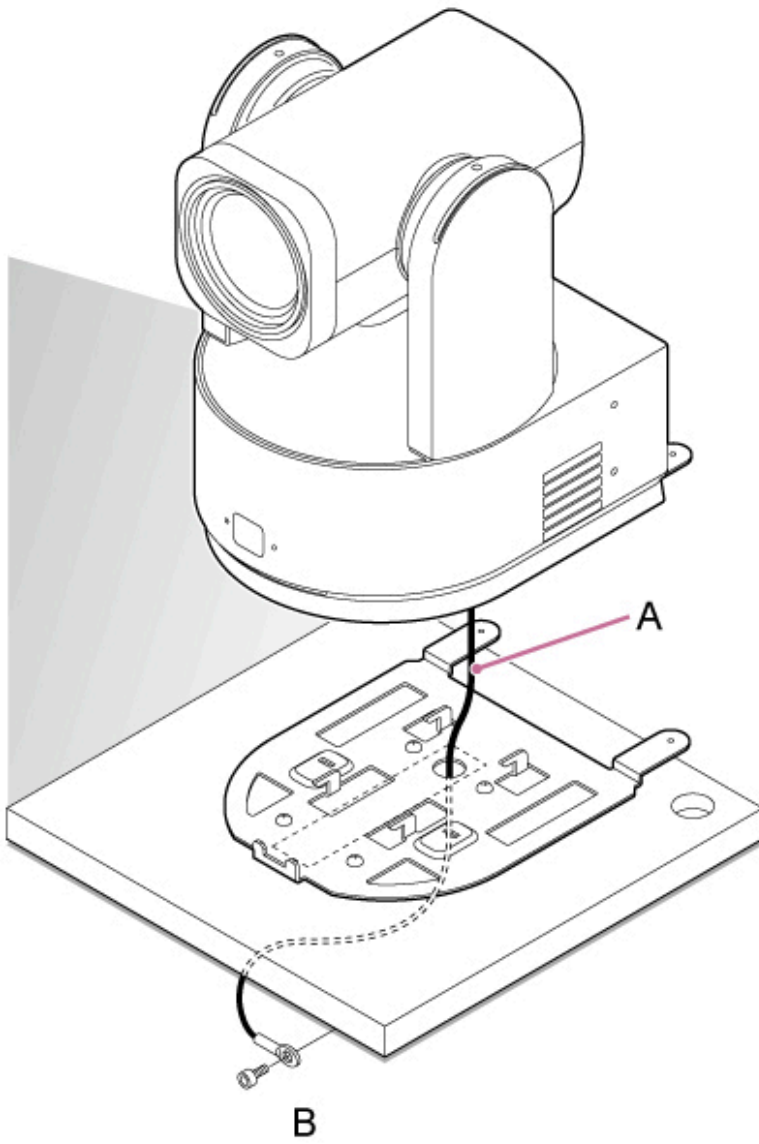

A: Wire rope
 B: Hexagon socket head cap screw (M5, 3/16 inch)

6 Align the edges of ceiling brackets (A) and (B).

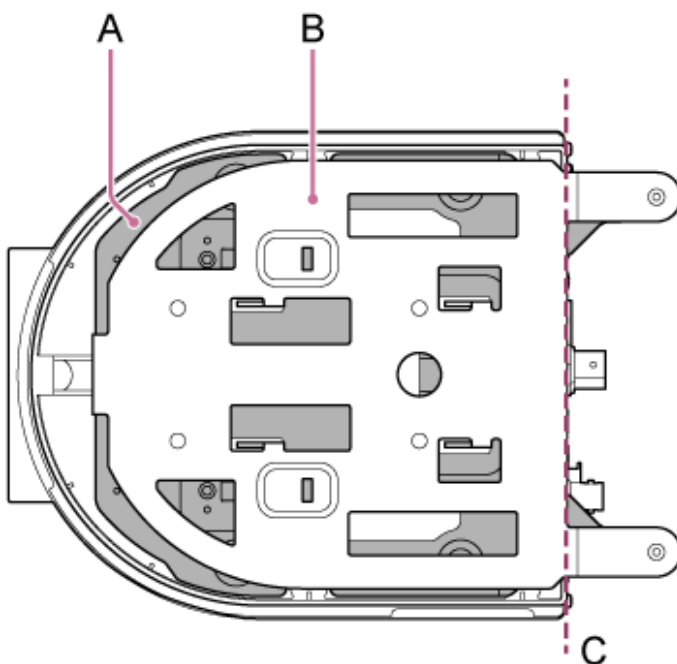

- A: Ceiling bracket (A) attached to the unit
- B: Ceiling bracket (B)
- C: Align the edges

- 7 Insert the protrusions of ceiling bracket (B) into the holes (4 places) of ceiling bracket (A).
- 8 Hook the fall prevention wire rope around the wire rope protrusion of ceiling bracket (A), push the unit in the direction shown in the illustration approximately 10 mm to temporarily secure it in place.

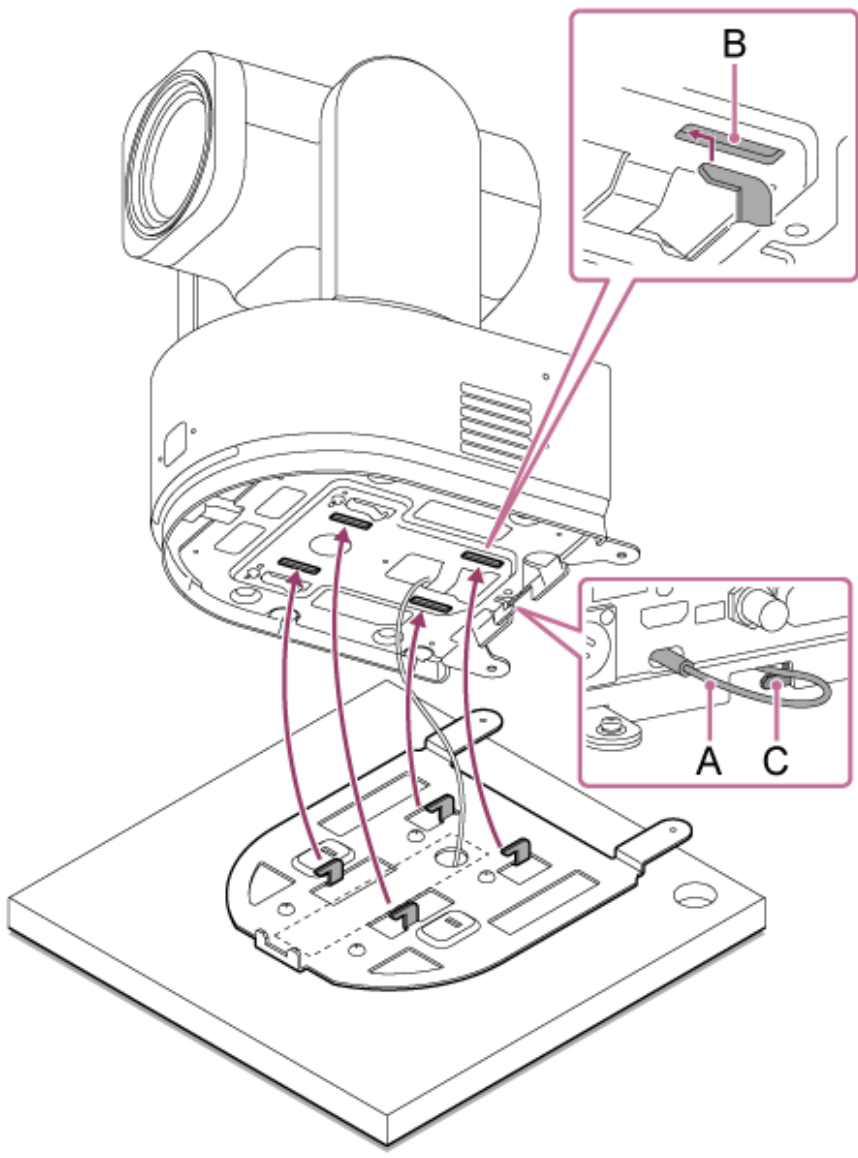

- A: Fall prevention wire rope
- B: Protrusion insertion holes (4 places)
- C: Wire rope protrusion

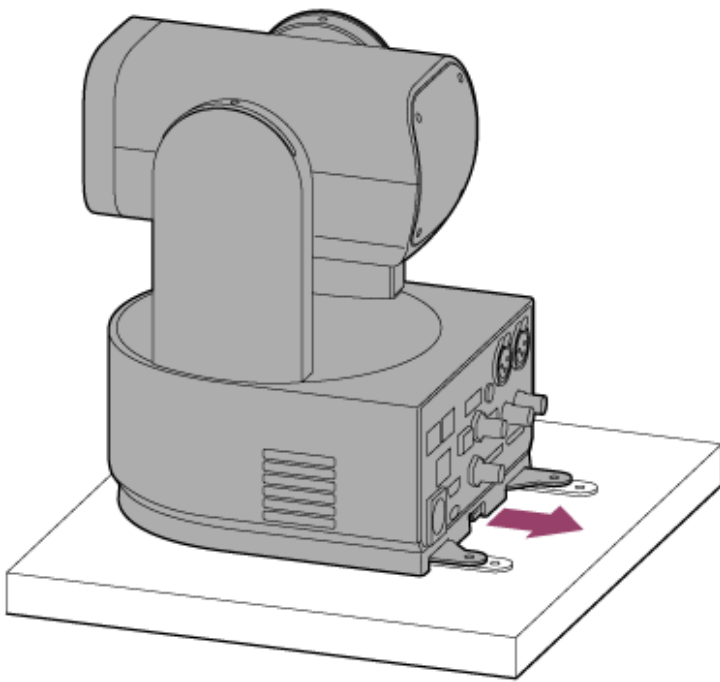

9 Attach ceiling bracket (A) and ceiling bracket (B) using the two supplied screws (M3×8).

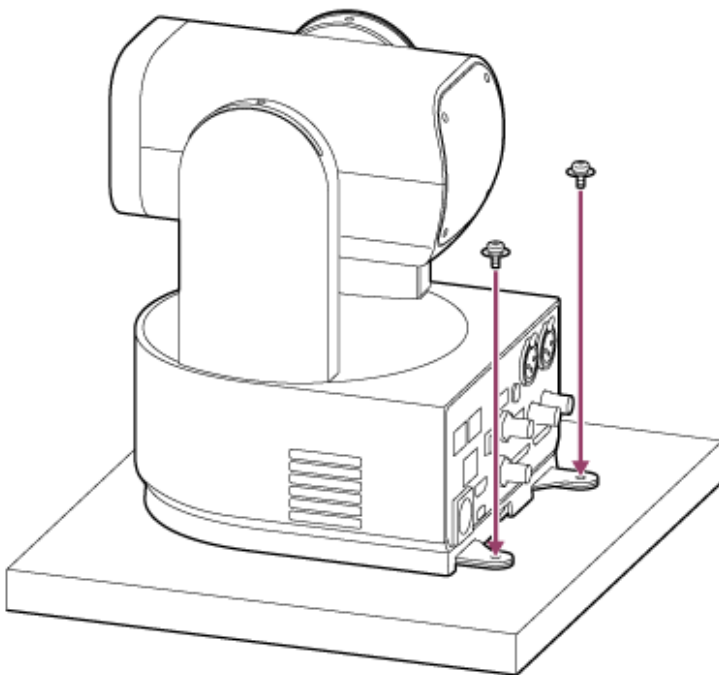

10 Check the mounting status.

Specifically, check the following items.

- Mounting screws are correctly attached.
- Fall prevention wire rope is correctly attached and is not twisted.
- Unit is mounted level (without tilt or wobble).

Color Video Camera
BRC-AM7

Mounting on a Ceiling

This topic describes how to mount the unit on a ceiling using the supplied ceiling bracket.

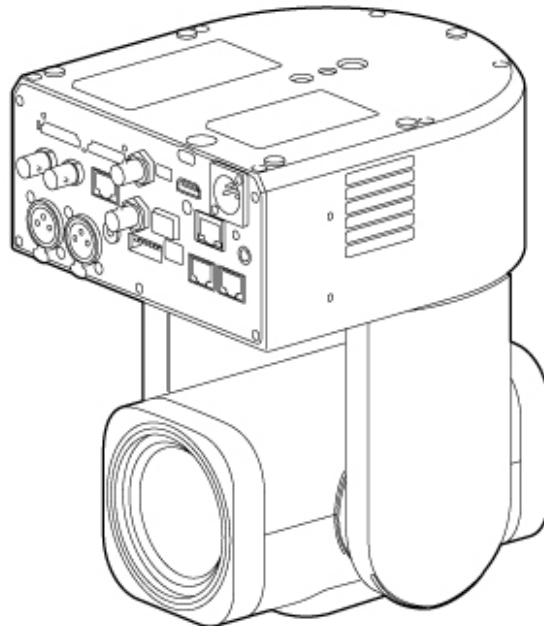

WARNING

- To mount the unit on a ceiling, ask a professional contractor.
- When mounting on a ceiling, make sure that the mounting surface and mounting material (excluding accessories) can support 200 kg (440 lb 15 oz) or more, and mount the unit as described in this Help Guide. If the mounting is not sturdy enough, the unit may fall and cause serious injury.
- Attach the supplied fall prevention wire rope to the unit to prevent the unit from falling.
- When the unit is mounted on a ceiling, check that the mounting has not become loose once a year. Shorten the inspection interval according to the usage conditions.

Installation note

- To prevent unit failure, do not hold the camera head while working.

1 Check the ceiling mounting accessories and mounting space.

Before you start, check that you have the following parts.

- Ceiling bracket (A) (1)
- Ceiling bracket (B) (1)
- Fall prevention wire rope (1)
- +PSW M3×8 screws (6)
- +PSW M4×8 stainless steel screw for fall prevention wire rope (1)

Note

- The fall prevention wire rope is designed to support the unit when suspended. Do not apply any load to it other than the load of the unit.

Mounting space

Refer to the following drawing when determining the mounting location and direction, taking into consideration the space required for turning the lens and the wiring at the rear of the unit.

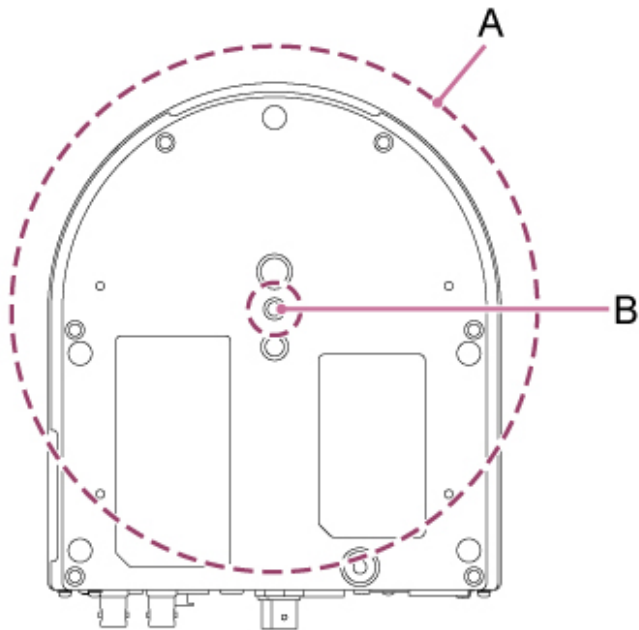

A: Camera head range of movement ($\varnothing 199$ mm)

B: Mounting wire rope feed hole ($\varnothing 20$ mm)

Note

- Mount on a ceiling (such as concrete) with sufficient strength.
- To mount the unit on a ceiling with insufficient strength, provide sufficient reinforcement.
- Mount it in a stable location that is not subject to vibration. Locations subject to vibration may cause vibration in the image.
- If the unit must be mounted on an inclined surface, keep it within $\pm 15^\circ$ of the horizontal and take measures to prevent the unit from falling.

2 Attach ceiling bracket (A) to the bottom of the unit using the four supplied screws (M3×8).

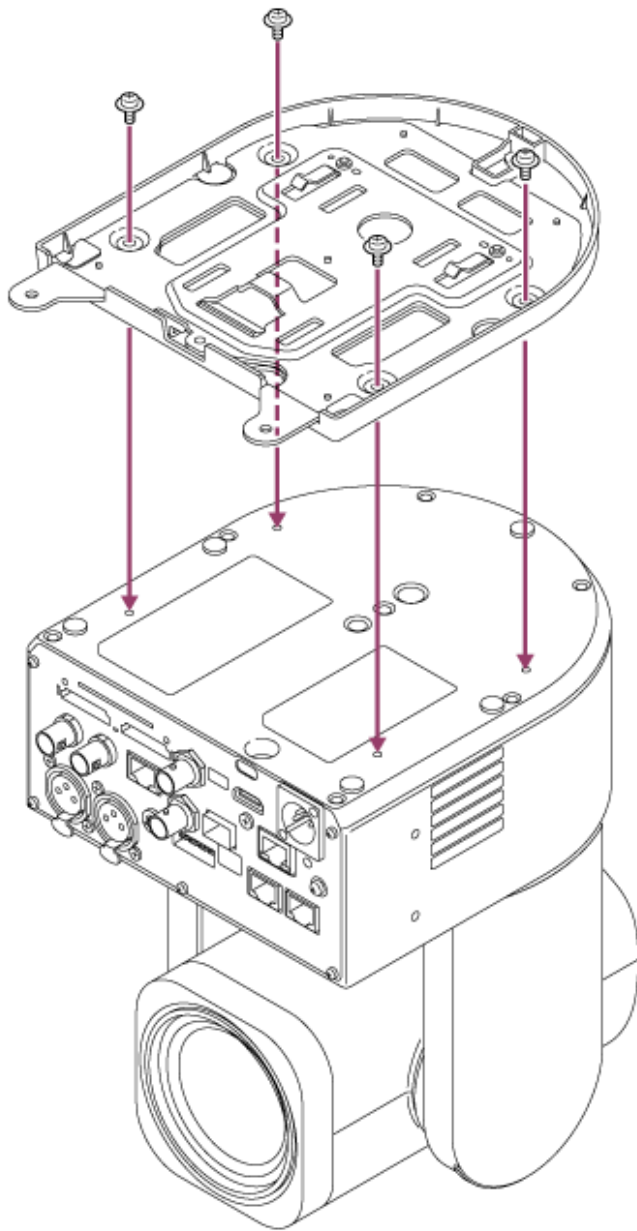

CAUTION

Use the supplied screws. The use of screws other than the supplied screws may damage the interior of the unit.

3 Attach ceiling bracket (B) to the ceiling using a mounting plate (option).

Note

- If the strength of the ceiling material cannot be ensured, install the unit between a concrete ceiling and ceiling board using mounting plate that is supported by anchor bolts.

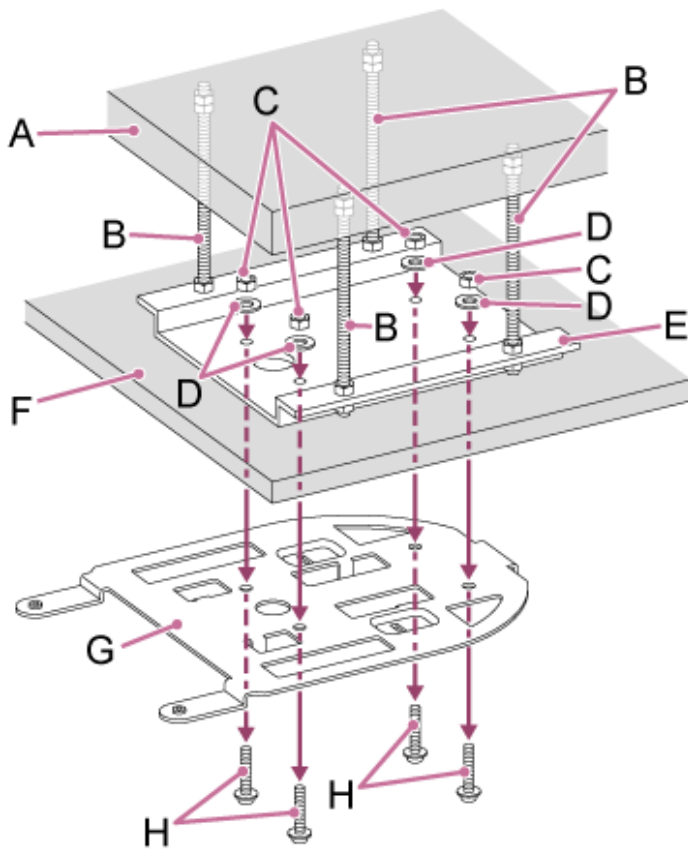

- A: Concrete ceiling
- B: Anchor bolts (4, not supplied)
- C: Nuts (4, not supplied)
- D: Washers (4, not supplied)
- E: Mounting plate (not supplied)
- F: Ceiling board
- G: Ceiling bracket (B)
- H: Mounting screws (4, not supplied)

Attach the bracket, according to the orientation of ceiling bracket (B).

Note that when mounted on a ceiling, the front of the camera is on the opposite side of the ceiling bracket in comparison to a normal upright mounting. The arrow direction in the figure indicates the front of the camera. Adjust the camera orientation so that it faces forward.

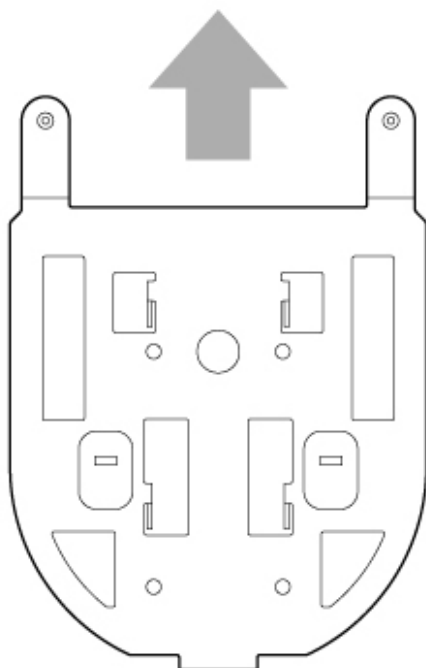

Note

- The mounting screws and mounting surface material are the responsibility of the customer.

4 Attach the fall prevention wire rope to the ceiling.

Use an M5 (3/16 inch) hexagon socket head cap screw (not supplied) for the mounting screw.

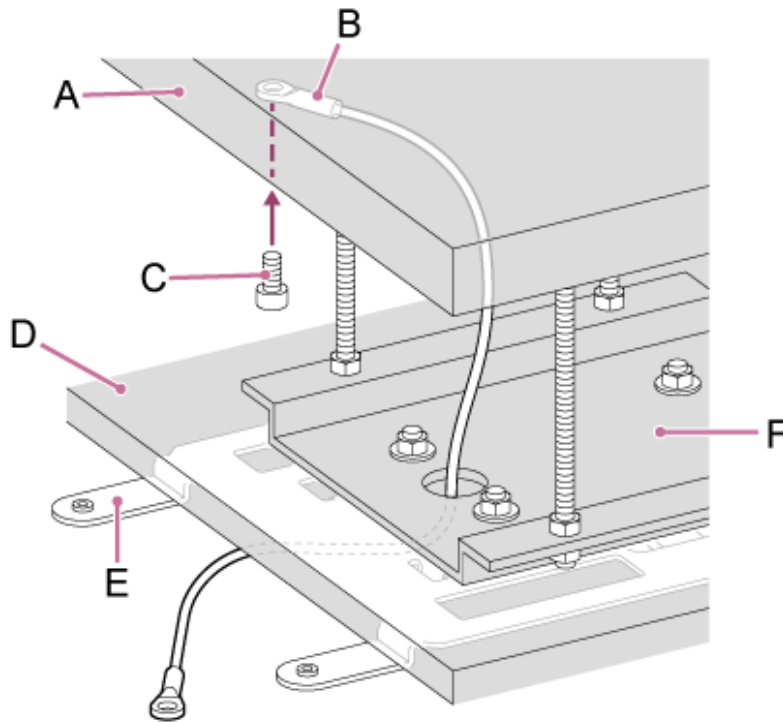

- A: Concrete ceiling
- B: Wire rope (supplied)
- C: M5 (3/16 inch) hexagon socket head cap screws (not supplied)
- D: Ceiling board
- E: Ceiling bracket (B)
- F: Mounting plate (not supplied)

5 Pull the fall prevention wire rope through the hole in the center of ceiling bracket (B), and attach it to the unit.

Route the fall prevention wire rope through the wire rope metal loop of ceiling bracket (A) and attach it securely to the unit using the supplied screw (M4×8).

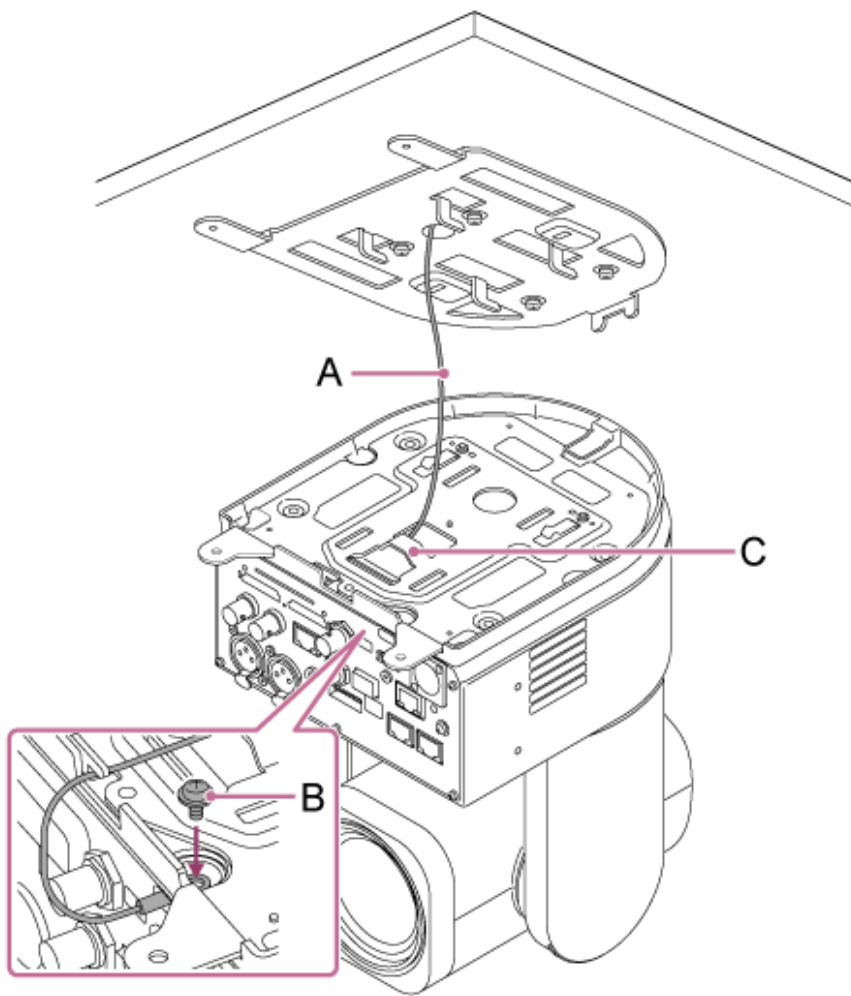

- A: Supplied wire rope
- B: Supplied screw (M4×8)
- C: Wire rope metal loop

WARNING

Use the supplied screw. The use of a screw other than the supplied screw may reduce the effectiveness of the wire rope function.

Note

- It is recommended that one person holds the unit as shown in the following diagram while another person mounts the unit.

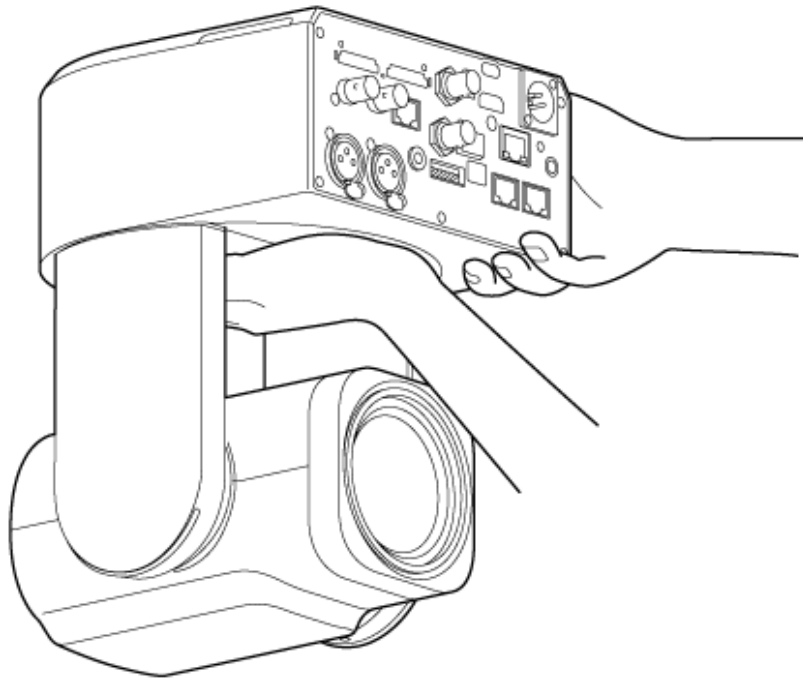

- Do not hold the camera head while mounting the unit. There is a risk of damage or injury if the unit is dropped or falls.
- Take care when wiring that electrical connectors and cables do not become short-circuited by the fall prevention wire rope.
- The combined unit should be suspended alone (maximum estimated mass 3.5 kg (7 lb 11 oz)). To prevent the unit falling, do not exceed the maximum expected mass.

6 Align the edges of ceiling brackets (A) and (B).

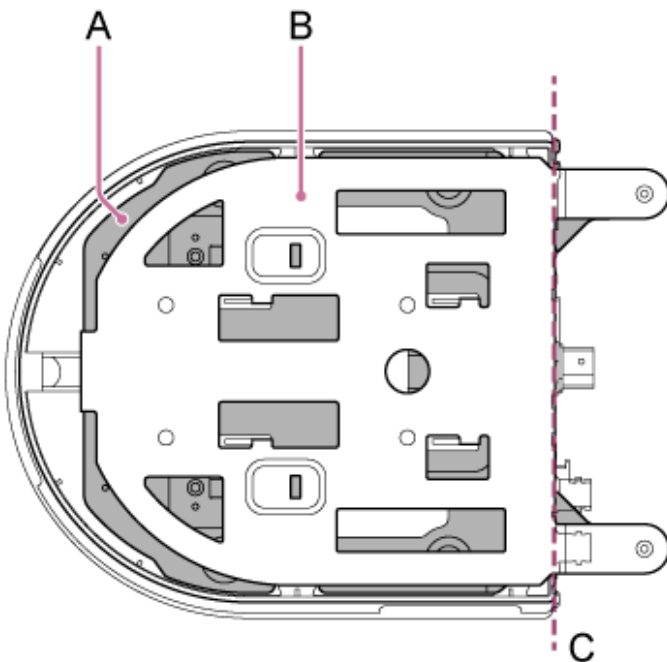

- A: Ceiling bracket (A) attached to the unit
- B: Ceiling bracket (B)
- C: Align the edges

7 Insert the protrusions of ceiling bracket (B) into the holes (4 places) of ceiling bracket (A).

8 Hook the fall prevention wire rope around the wire rope protrusion of ceiling bracket (A), push the unit in the direction shown in the illustration approximately 10 mm to temporarily secure it in place.

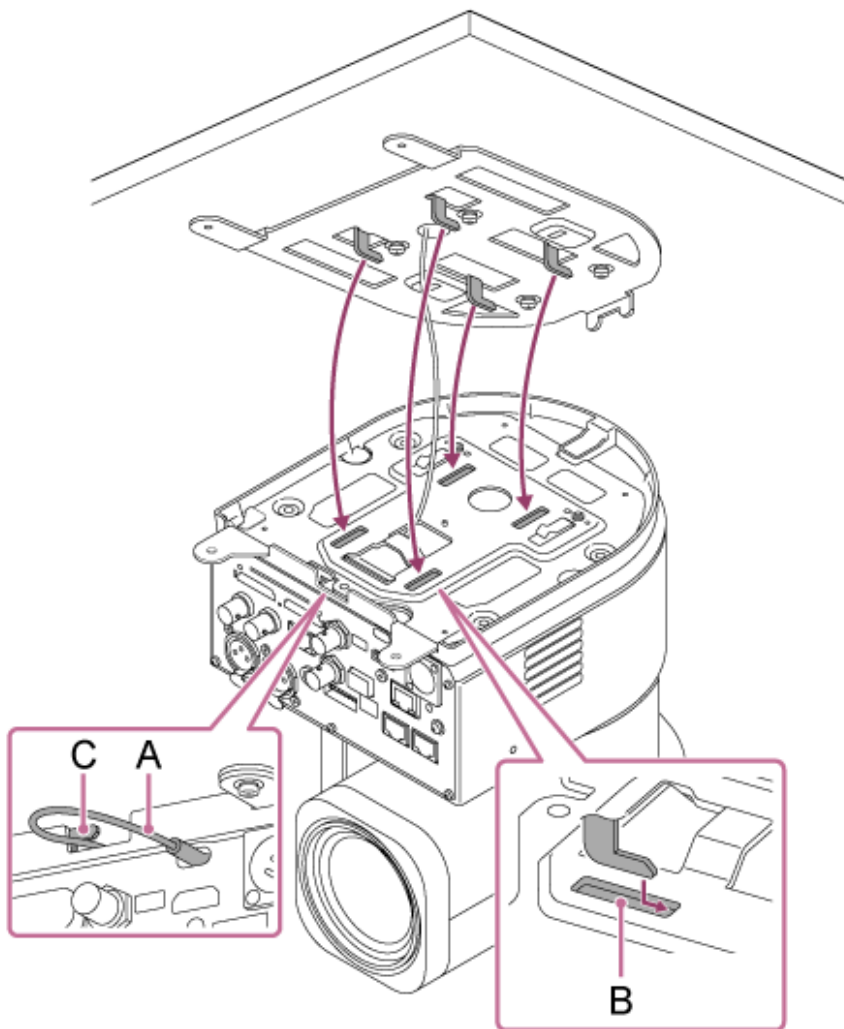

- A: Fall prevention wire rope
- B: Protrusion insertion holes (4 places)
- C: Wire rope protrusion

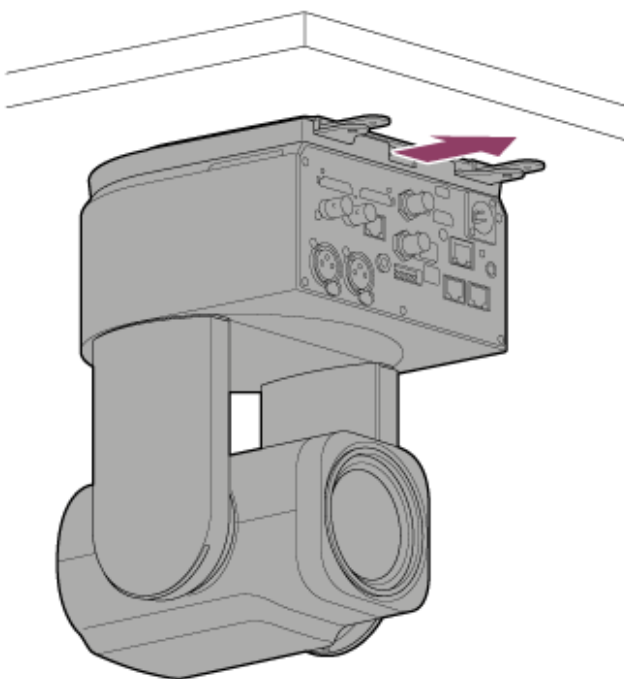

9 Attach ceiling bracket (A) and ceiling bracket (B) using the two supplied screws (M3×8).

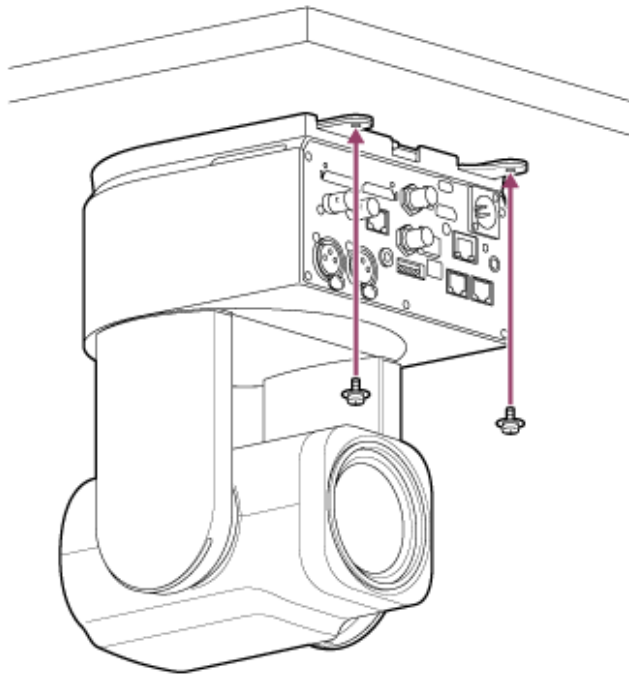

10 Check the mounting status.

Specifically, check the following items.

- Mounting screws are correctly attached.
- Fall prevention wire rope is correctly attached and is not twisted.
- Unit is mounted level (without tilt or wobble).

Note

- To operate the pan/tilt correctly when the unit is mounted on a ceiling, set [Pan-Tilt] – [Direction] – [Ceiling] to [On] in the web menu.

TP1001804470

Color Video Camera
BRC-AM7

Connecting Cables

This topic describes cable connections.

1 Connect the required cables to the connectors on the rear panel.

Use a cable that complies with the standards of the unit.
The following shows an HDMI cable connection example.

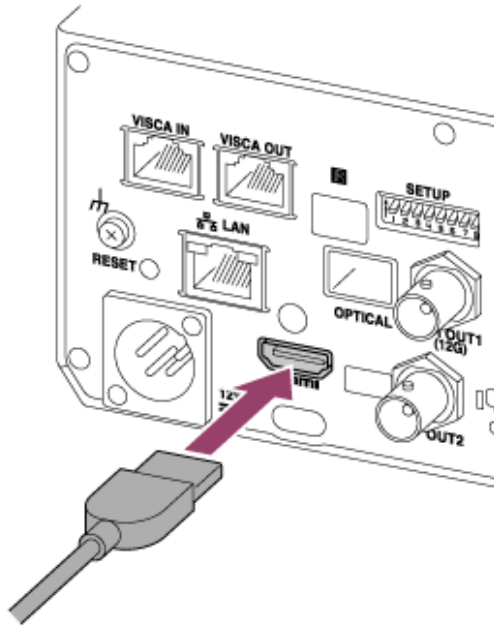

TP1001804471

Connecting the Unit to a Network Device Via Wired Connection

This topic describes connecting the unit to a network device via a wired connection.

- 1 **Connect the unit to a network device (such as a Wi-Fi access point or switching hub) using a Category 5e or higher LAN cable.**

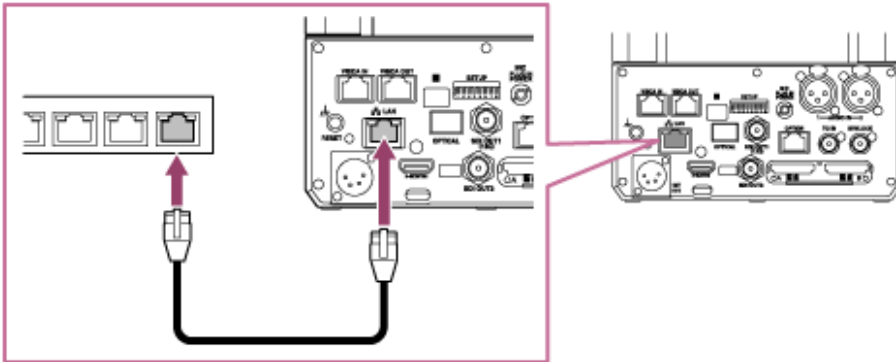

- 2 **Access the Web App and configure the initial settings of the unit.**

For details, see “Accessing the Web App from a Web Browser” and “Initializing the Unit.”

Connecting to a network without a DHCP server

The unit is configured by factory default to obtain an IP address automatically from a DHCP server. In general, commercially available Wi-Fi routers are equipped with a DHCP server function. However, if connecting to a network that does not have a DHCP server, set a fixed IP address using the following procedure.

1. Remove the power supply from the unit.
2. Set SETUP switch 8 to the ON position on the connector block (fixed IP address mode).

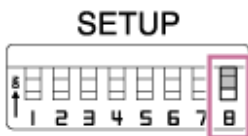

3. Connect the power supply to the unit.
The IP address of the unit will be set to 192.168.0.100, regardless of the IP address setting in the web menu.
4. Set the IP address of the setup computer to a unique address on the same network, such as 192.168.0.200.
5. Connect the setup computer and unit directly using a LAN cable.
6. On the setup computer, enter “192.168.0.100” in the address bar of a web browser
The Web App of the unit is displayed. You will be prompted to enter the user name and password. Configure settings as described in “Initializing the Unit.”
7. Configure the following in [Network] – [Wired LAN] – [IPv4] in the web menu and press the [OK] button.
The settings are examples only. Change the settings according to the network to connect.

Item	Setting	Remarks
[DHCP]	[Off]	
[IP Address]	192.168.0.101	The last segment should be a number that is unique among other devices connected to the same network.

Item	Setting	Remarks
[Subnet Mask]	255.255.255.0	
[Gateway]	192.168.0.1	Configure the settings according to the network.

8. Wait about 10 seconds and then remove the power supply from the unit.
9. Set SETUP switch 8 to the OFF position on the connector block.
10. Reconnect the unit to the network LAN cable.
11. Connect the power supply to the unit.
12. Enter the IP address configured in step 7 in a web browser connected to the network.
The Web App screen appears.

Related Topic

- [Initializing the Unit](#)

TP1001804472

Connecting to the Unit using a Remote Controller (Option) via RS-422

This topic describes how to connect a remote controller to the unit using the RS-422 connector. An RS-422 connection supports connections of up to 1.2 km (max).

You can also daisy-chain up to seven cameras using the VISCA OUT connector.

To configure the initial settings of the unit, a PC or tablet must be connected to the LAN connector.

Note

- Perform the following procedure before connecting the power supply to the unit.

1 Set SETUP switch 4 to the ON position on the connector block of the unit.

VISCA communication is enabled.



2 Set the baud rate using SETUP switch 5 on the connector block of the unit to the same baud rate as the remote controller.

Switch 5 setting	Baud rate
ON	38400 bps
OFF	9600 bps

3 Connect the VISCA IN connector of the unit to the VISCA connector of the remote controller using a commercially available network cable.

The following shows an RM-IP500 connection example.

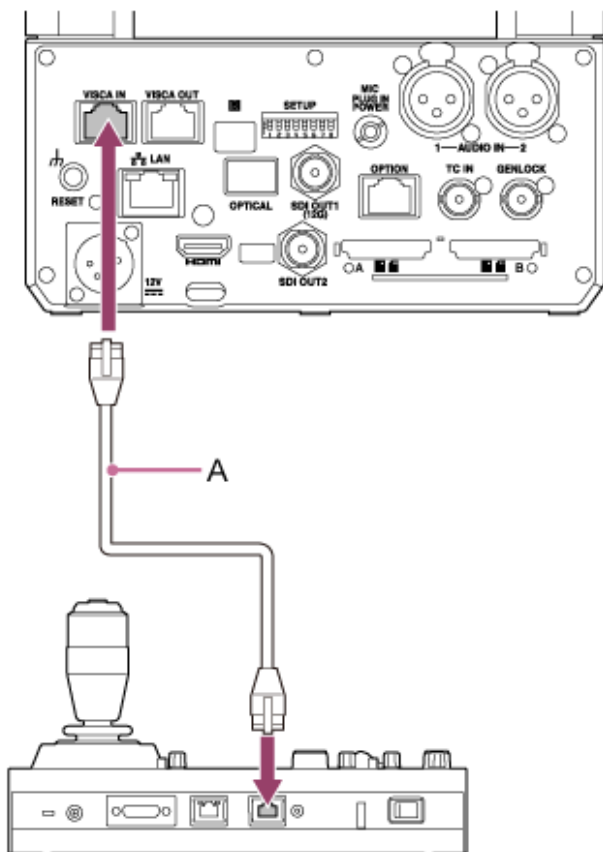

A: Commercially available network cable

Note

- Use a straight cable for the network cable.
- To connect a VISCA device that has its own connector using other than RM-IP500, create a connection cable by referring to the pin layout shown below.

VISCA RS-422 pin layout (left: VISCA IN, right: VISCA OUT)

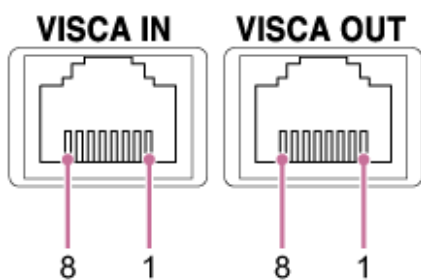

IN		OUT	
Pin No.	Function	Pin No.	Function
1	TX-	1	RX-
2	TX+	2	RX+
3	RX-	3	TX-
4	GND	4	GND
5	GND	5	GND
6	RX+	6	TX+

IN		OUT	
7	N.C.	7	N.C.
8	N.C.	8	N.C.

Refer to the following when connecting multiple cameras in a daisy-chain.

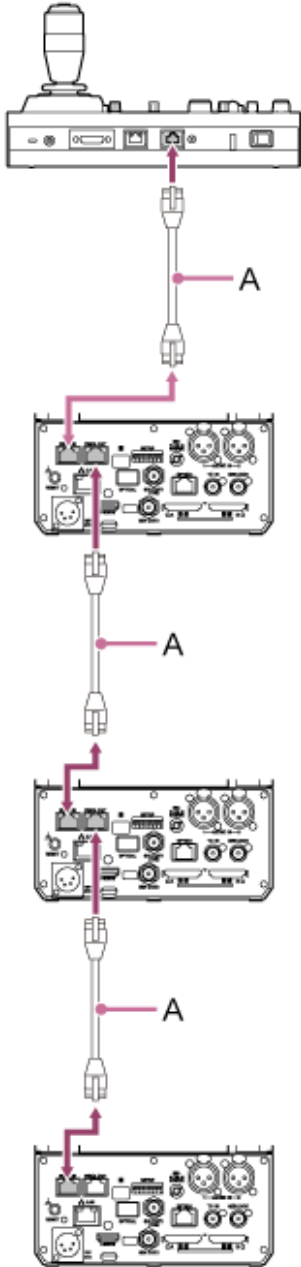

A: Commercially available network cable

4 Turn the unit on.

Color Video Camera
BRC-AM7

Using DC Power

This topic describes the procedure to power the unit using DC power.

The unit supports DC power input.

The supported input voltage range is 11 V to 17 V. If the input voltage drops, a [Voltage Low] or [Insufficient Voltage] alarm will be displayed.

Note

- If [Insufficient Voltage] is displayed, the unit must be restarted to restore full normal operation. Prepare a power source that provides stable voltage and current.

- 1 Connect a DC power cable (sold separately) to the DC IN connector on the connector block.

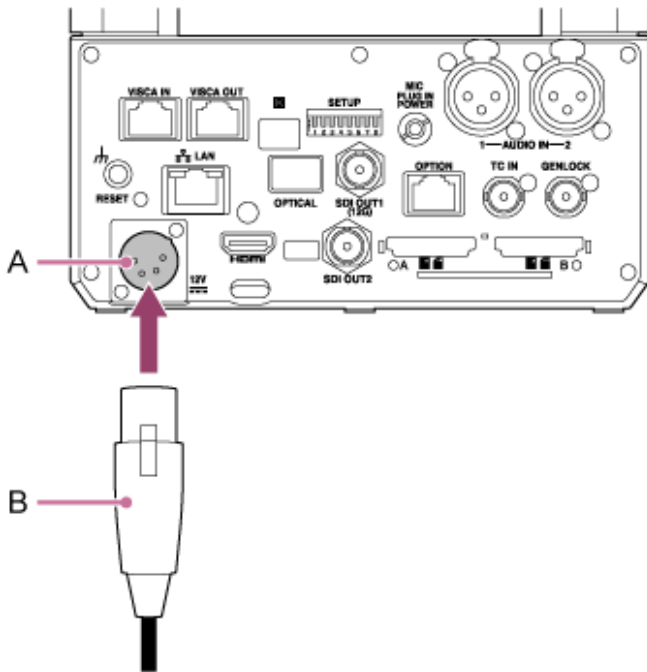

A: DC IN connector

B: DC power cable (sold separately)

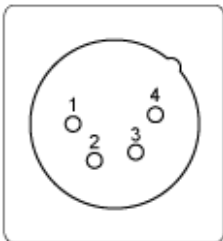

No.	Signal
1	GND
2	NC
3	NC

No.	Signal
4	DC IN (11 V to 17 V)

- 2 Check that the POWER lamp on the front of the unit changes from blinking green to solid green and that startup has finished.**

When the unit has started normally and connected to the network, the NETWORK lamp will light up green.

TP1001804474

5-065-326-11(1) Copyright 2024 Sony Corporation

Color Video Camera
BRC-AM7

Using PoE++ Power

When the unit is connected to a PoE++ compatible power delivery device, power is supplied to the unit via a commercially available network cable.

This method enables power to be supplied to the unit without the need for power supply wiring in environments where there is no power supply outlet near the mounting location.

However, the following functions cannot be used during operation using a PoE++ power supply.

- Clip recording/playback
- Recording media initialization/update
- Video output from the OPTICAL connector

Also, the pan/tilt acceleration is restricted.

- 1 **Connect the unit and a PoE++ compatible power delivery device using a commercially available network cable.**

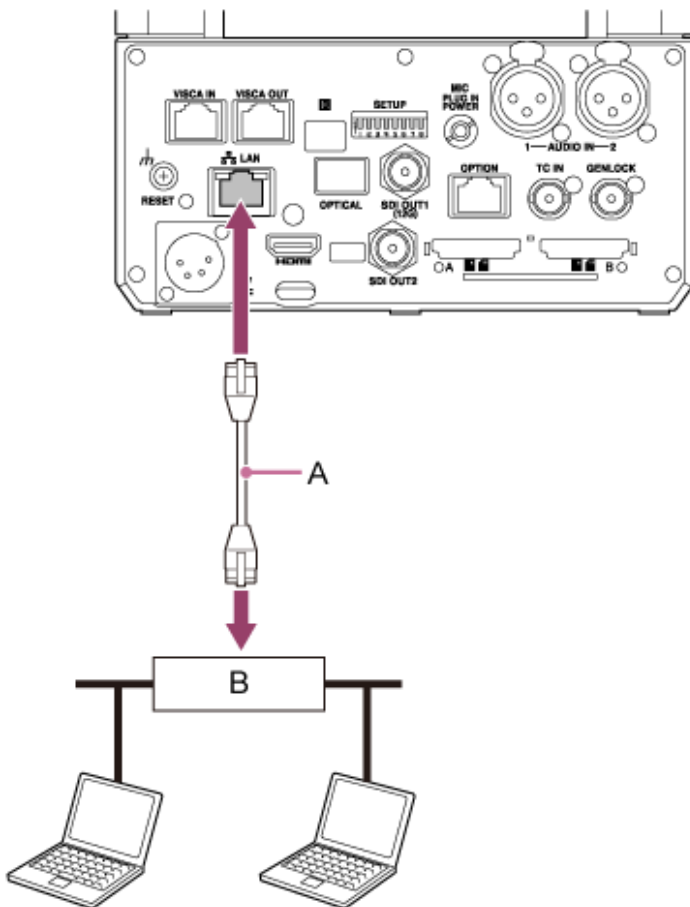

A: Network cable

B: PoE++ compatible power delivery device

- 2 **Check that the POWER lamp on the front of the unit changes from blinking green to solid green and that startup has finished.**

When the unit has started normally and connected to the network, the NETWORK lamp will light up green.

Note

- When power is supplied by PoE++, initial authentication is performed during the interval until startup has finished.

Note

- The unit conforms to IEEE802.3bt Type 4 Class 8. For details about verified compatible PoE++ power delivery devices, contact your dealer or Sony service representative.
- The unit is compliant with soft authentication (LLDP), but it may be necessary to configure network devices (IEEE802.3bt compliant).
- Do not connect a DC power cable to the DC IN connector when using PoE++ power delivery with soft authentication (LLDP) enabled.
- If a DC power supply and PoE++ power delivery device are connected at the same time, power is supplied from the DC power supply.
- When supplying power via PoE++, use a Category 5e or higher network cable.
- Wait about 10 seconds after turning the unit on again when powered via PoE++.
- When connecting via PoE++ power delivery, do not run wiring outdoors.

TP1001804475



5-065-326-11(1) Copyright 2024 Sony Corporation

Resetting the Pan/Tilt

You can reset the pan/tilt using the following procedure.

1 Execute the pan/tilt reset function.

Pan/tilt reset can be executed from the infrared remote control, Web App, or the RM-IP500 Remote Controller (option).

- Operation using the infrared remote control: Press the P/T RESET button.
- Operation using the Web App: Press the  (Pan/tilt reset) button on the  (Others) tab in the camera control panel on the live operation screen.
- Operation using the RM-IP500: Refer to the operating instructions for the RM-IP500.

Note

- Executing pan/tilt reset causes the camera head to turn. Check that the lens is not obstructed before executing.
- The unit has a function that limits the pan/tilt range, but this function is disabled when the unit is turned on or pan/tilt reset is executed.

Hint

- When pan/tilt reset is completed, the unit returns to the pre-execution position.

Accessing the Web App from a Web Browser

By connecting the unit to a tablet or computer, you can operate and configure the unit from a web browser.

1 Check whether your tablet or computer supports Web App operations.

Item		Requirement	
Display		1080×810 pixels or higher recommended Tablet display size: 10-inch or larger recommended	
Supported OS and web browser	Windows	OS	Windows 10 or later
		Web browser	Google Chrome
	Mac	OS	macOS 10.15 or later
		Web browser	Google Chrome Safari
	iPad	OS	iPadOS 15 or later
		Web browser	Google Chrome Safari
	Android	OS	Android 12 or later
		Web browser	Google Chrome

Note

- If the required environment is not satisfied, or depending on the usage of the tablet/computer, video display in a web browser may be adversely affected.
- The Web App of this unit uses JavaScript. If using antivirus software on your tablet/computer, the web page may not be displayed correctly.

2 Check that the unit, tablet or computer, and peripheral devices are turned on.

3 Check that the unit is connected via wired LAN local area connection.

4 Check that the tablet or computer are connected via Wi-Fi or wired LAN local area connection.

5 Connect to the unit from the web browser of your tablet or computer.

Connecting using a QR code

Scan the QR code attached to the bottom of the unit or the supplied QR code seal using the camera of the tablet. Open the displayed link on the tablet.

The web browser on the tablet launches and displays the Web App screen of the unit.

Connecting by entering a URL in the address bar of a web browser

Launch a web browser on the tablet or computer, and enter the URL printed on the QR code attached to the bottom of the unit or the supplied QR code seal.

The web browser should display the Web App screen of the unit.

Connecting by entering the IP address of the unit in the address bar of a web browser

Launch a web browser on your tablet or computer and enter “http://IP address of the unit” in the address bar.

The web browser should display the Web App screen of the unit.

Note

- If the HTTP port number was changed from a value of 80, enter “http://IP address of the unit:Port number” in the address bar.
- When connecting using a QR code or by entering the URL in the address bar of a web browser, use a device that supports mDNS*.
* mDNS: A communication protocol used to determine the IP address from a host name on a local network.

Hint

- You can subsequently access the unit quickly using the bookmark function of the web browser.
- The supplied QR code seal should be placed in a location that is easy to read when you need to reconnect to the unit installed in a difficult to reach location, such as a high location.

TP1001804477

Color Video Camera
BRC-AM7

Initializing the Unit

Make sure to configure the unit using the following procedure when using the unit for the first time.
For details about accessing the Web App, see "Accessing the Web App from a Web Browser."

Hint

- If the backup battery becomes completely discharged, you will need to configure the initial setup again.

1 Connect to the unit from a tablet or computer, and launch the Web App.

When the unit is used for the first time, you will be prompted to enter a user name and password in the web browser.
Enter the following settings.

- User name: admin
- Password: (leave blank)

Follow the on-screen instructions to configure the initial setup.

2 Enter the administrator (Administrator) user name and password, and press the [OK] button.

The screenshot shows a user configuration interface. The title is "User" and the user type is "Administrator". There are three input fields: the first contains "admin" and is labeled "1"; the second is labeled "New Password" and is labeled "2"; the third is labeled "Re-type password" and is labeled "3". A question mark is next to the third field. At the bottom left is a "Reload" button, and at the bottom right is a yellow "OK" button.

1: Enter the administrator user name.

2: Set the administrator password.

3: Enter the same password again for confirmation.

Note

- The following characters can be used in the user name and password. The password must include at least one upper case letter, one lower case letter, one number, and be 8 to 64 characters in length.
 - Alphanumeric characters

Your web browser will reload and you will be prompted to enter the user name and password.

3 Enter the user name and password that were configured in step 2.

The language and clock setup screen appears.

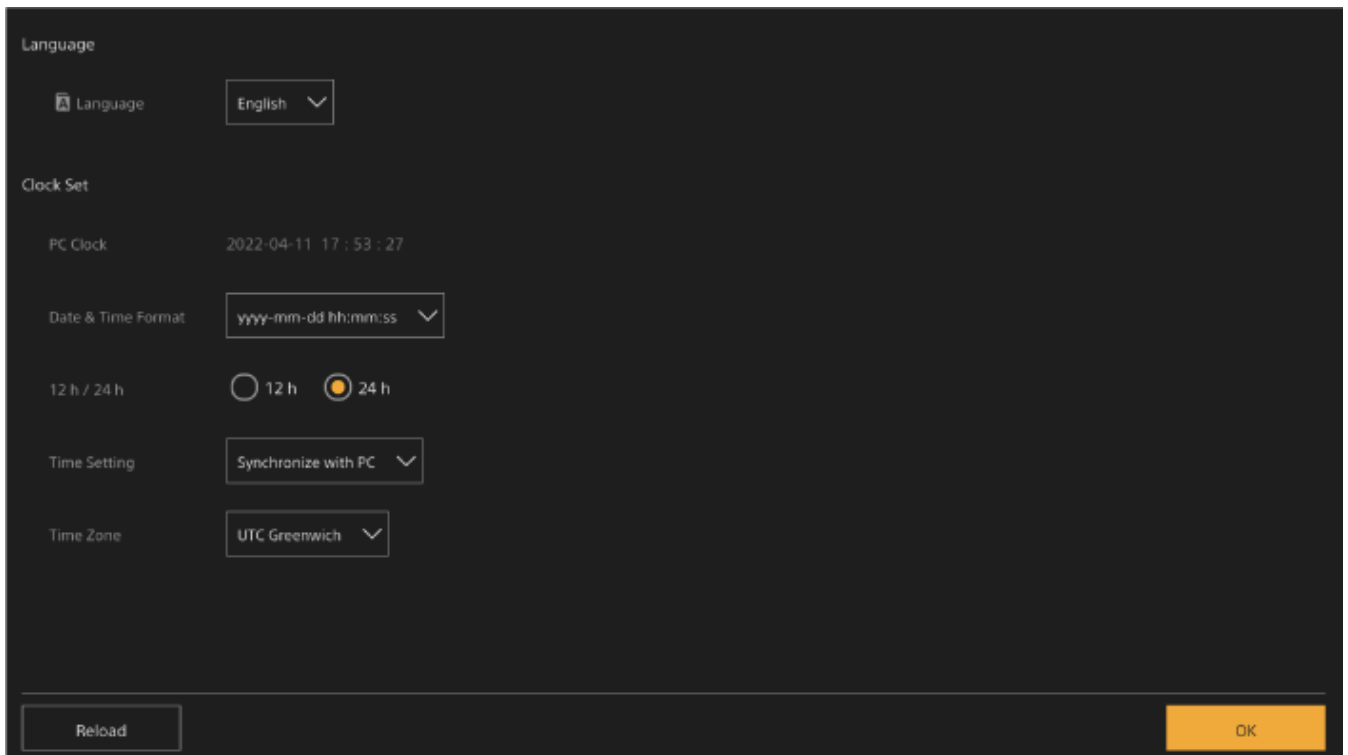

4 Specify the following items and press the [OK] button.

[Language]

Select the language to use for the Web App and camera screen display. Changing the language will change the Web App display language.

[Date & Time Format]

Select the display format for the date and time from the following options.

[yyyy-mm-dd hh:mm:ss], [mm-dd-yyyy hh:mm:ss], [dd-mm-yyyy hh:mm:ss]

“yyyy” indicates the year, “mm” indicates the month, “dd” indicates the day, “hh” indicates the hour, “mm” indicates the minute, and “ss” indicates the second, respectively.

[12 h/24 h]

Select [12 h] (12-hour clock) or [24 h] (24-hour clock) for the time display.

[Time Setting]

Select the method for setting the date/time.

[Synchronize with PC]: Synchronize to the date/time of the computer or tablet.

[Manual setting]: Set manually. When this method is selected, entry fields for the date and time appear.

[Time Zone]

Select the time zone.

The live screen for shooting operations appears. Continue to configure the basic operation of the unit according to the operation mode.

Hint

- In some cases, such as when using the unit with a tablet as a pair, it may be easier to use a fixed IP address for the unit.
- To set a fixed IP address, first turn off [Network] – [Wired LAN] – [DHCP] (slider switch in the left position) in the web menu.

- The setup items related to a fixed IP address appear. Configure the items then press the [OK] button on the screen.

Related Topic

- [Accessing the Web App from a Web Browser](#)

TP1001804478

5-065-326-11(1) Copyright 2024 Sony Corporation

Resetting Unit Settings

This topic describes how to reset the settings of the unit.

The settings that are reset vary depending on the setting of SETUP switch 3 on the connector block.

1 Connect the power supply to the unit.

2 Set SETUP switch 3 on the connector block of the unit.

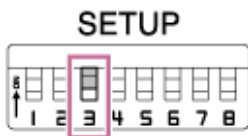

- To restore only the network settings to the factory default state, set switch 3 to OFF.
- To restore all settings of the unit to the factory default state, set switch 3 to ON.

3 Use the tip of a pen or other narrow object to press and hold the RESET switch for at least 5 seconds.

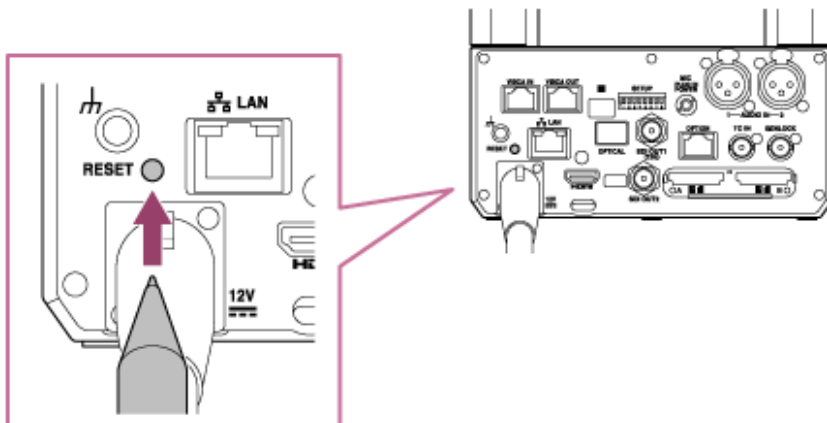

The settings are reset and the unit reboots.

Color Video Camera
BRC-AM7

Configuring Basic Operation

This topic describes how to configure the unit for basic operations.

Setting the shooting mode

You can select the shooting mode of the unit to match the workflow.

- Custom mode: Flexibly create images during shooting.
- Log shooting mode: Records S-Log content.
 - Flexible ISO mode: Exposure settings are set by ISO value adjustments matching the scene being shot.

Switch the shooting mode using [Project] – [Base Setting] – [Shooting Mode] in the web menu or camera menu.

Custom mode

You can select the video standard.

Switch using [Project] – [Base Setting] – [Target Display] in the web menu or camera menu.

- [SDR(BT.709)]: Shooting according to HD broadcast standard
- [HDR(HLG)]: Shooting according to next generation 4K broadcast standard

For details, see “Look Overview” and other topics in “Shooting with the Desired Look.”

Log shooting mode (Flexible ISO mode)

In Log shooting mode, you select the base color gamut for recorded signals and output signals. The color gamut selected here is the color gamut of the video output when the [LUT On/Off] settings are set to [LUT Off].

You can switch the color gamut using [Project] – [Flexible ISO Setting] – [Color Gamut] in the camera menu.

- [S-Gamut3.Cine/SLog3]: Easy to adjust color gamut for digital cinema (DCI-P3).
- [S-Gamut3/SLog3]: Sony wide color gamut that covers the ITU-R BT.2020 color gamut.

For details, see “Shooting with Look Adjustment in Post-Production.”

Supported functions in each shooting mode are given in the following table.

●: Supported, –: Not supported

	Custom	Flexible ISO
[ISO/Gain]	●	● (ISO only)
[LUT On/Off]	–	●
[Scene File]	●	–
[Paint/Look] (excluding [Base Look])	●	–

Setting the system frequency

Switch using [Project] – [Rec Format] – [Frequency] in the web menu or camera menu. The unit may reboot automatically after switching, depending on the selected value.

Note

- You cannot switch the system frequency during recording or playback.

Setting the codec

You can set the codec for recording.

Switch using [Project] – [Rec Format] – [Codec] in the web menu or camera menu.

Note

- You cannot switch the codec during recording or playback.

Setting the video format

You can set the video format for recording and the output format for output from the camera.

- Switch the video format for recording using [Project] – [Rec Format] – [Video Format] in the web menu or camera menu.
- Switch the output format from the SDI OUT and HDMI OUT connectors using [Monitoring] – [Output Format] in the web menu or camera menu.

Note

- You cannot switch the video format during recording or playback.
- Restrictions may apply to the SDI/HDMI/Stream signals, depending on the video format setting.

Setting the bit rate

You can set the bit rate for recording.

- Switch using [Project] – [Rec Format] – [Quality] in the web menu or camera menu.

Note

- You cannot switch the bit rate during recording or playback.

Related Topic

- [Look Overview](#)
- [Shooting with Look Adjustment in Post-Production](#)

TP1001804480

Color Video Camera
BRC-AM7

Memory Cards

The unit records audio and video on CFexpress Type A memory cards (available separately) or SDXC memory cards (available separately) inserted in the card slots.

CFexpress Type A memory cards

For details about CFexpress Type A memory cards* supported by the unit, see “Recommended Memory Cards.”

For details about operations with media from other manufacturers, refer to the operating instructions for the media or consult the manufacturer’s information.

*Referred to as “CFexpress cards” in this Help Guide.

SDXC memory cards

For details about SDXC memory cards* supported by the unit, see “Recommended Memory Cards.”

*Referred to as “SD cards” in this Help Guide.

TP1001868322

Recommended Memory Cards

The guaranteed operating conditions will vary depending on the [Rec Format] and recording settings.

Normal recording

✓ : Operation guaranteed

× : Operation not guaranteed

Recording format			[Bit Rate]	SDXC								CFexpress Type A	
System frequency	[Codec]	Resolution		Class 10	U1	U3	VSC V10	VSC V30	VSC V60	VSC V90	CFE200	CFE400	
119.88 Hz	XAVC HS Long 422	3840×2160	H	×	×	×	×	×	✓	✓	✓	✓	
			M	×	×	×	×	×	✓	✓	✓	✓	
			L	×	×	×	×	×	✓	✓	✓	✓	
	XAVC HS Long 420	3840×2160	H	×	×	×	×	×	✓	✓	✓	✓	
			M	×	×	×	×	×	✓	✓	✓	✓	
			L	×	×	×	×	×	✓	✓	✓	✓	
	XAVC S Long 422	3840×2160	H	×	×	×	×	×	✓	✓	✓	✓	
			M	×	×	×	×	×	✓	✓	✓	✓	
			L	×	×	×	×	×	✓	✓	✓	✓	
	XAVC S Long 420	3840×2160	H	×	×	×	×	×	✓	✓	✓	✓	
			M	×	×	×	×	×	✓	✓	✓	✓	
			L	×	×	×	×	×	✓	✓	✓	✓	
		1920×1080	H	×	×	✓	×	✓	✓	✓	✓	✓	✓
			M	✓	✓	✓	✓	✓	✓	✓	✓	✓	✓
			L	✓	✓	✓	✓	✓	✓	✓	✓	✓	✓

Recording format			[Bit Rate]	SDXC							CFexpress Type A	
System frequency	[Codec]	Resolution		Class 10	U1	U3	VSC V10	VSC V30	VSC V60	VSC V90	CFE200	CFE400
100 Hz	XAVC HS Long 422	3840×2160	H	x	x	x	x	x	✓	✓	✓	✓
			M	x	x	x	x	x	✓	✓	✓	✓
			L	x	x	x	x	x	✓	✓	✓	✓
	XAVC HS Long 420	3840×2160	H	x	x	x	x	x	✓	✓	✓	✓
			M	x	x	x	x	x	✓	✓	✓	✓
			L	x	x	x	x	x	✓	✓	✓	✓
	XAVC S Long 422	3840×2160	H	x	x	x	x	x	✓	✓	✓	✓
			M	x	x	x	x	x	✓	✓	✓	✓
			L	x	x	x	x	x	✓	✓	✓	✓
	XAVC S Long 420	3840×2160	H	x	x	x	x	x	✓	✓	✓	✓
			M	x	x	x	x	x	✓	✓	✓	✓
			L	x	x	x	x	x	✓	✓	✓	✓
		1920×1080	H	x	x	✓	x	✓	✓	✓	✓	✓
			M	✓	✓	✓	✓	✓	✓	✓	✓	✓
			L	✓	✓	✓	✓	✓	✓	✓	✓	✓

Recording format			[Bit Rate]	SDXC							CFexpress Type A	
System frequency	[Codec]	Resolution		Class 10	U1	U3	VSC V10	VSC V30	VSC V60	VSC V90	CFE200	CFE400
59.94 Hz	XAVC HS Long 422	3840×2160	H	x	x	✓	x	✓	✓	✓	✓	✓
			M	x	x	✓	x	✓	✓	✓	✓	✓
			L	x	x	✓	x	✓	✓	✓	✓	✓
	XAVC HS Long 420	3840×2160	H	x	x	✓	x	✓	✓	✓	✓	✓
			M	x	x	✓	x	✓	✓	✓	✓	✓
			L	✓	✓	✓	✓	✓	✓	✓	✓	✓
	XAVC S Long 422	3840×2160	H	x	x	✓	x	✓	✓	✓	✓	✓
			M	x	x	✓	x	✓	✓	✓	✓	✓
			L	x	x	✓	x	✓	✓	✓	✓	✓
		1920×1080	H	✓	✓	✓	✓	✓	✓	✓	✓	✓
			M	✓	✓	✓	✓	✓	✓	✓	✓	✓
			L	✓	✓	✓	✓	✓	✓	✓	✓	✓
	XAVC S Long 420	3840×2160	H	x	x	✓	x	✓	✓	✓	✓	✓
			M	x	x	✓	x	✓	✓	✓	✓	✓
			L	x	x	✓	x	✓	✓	✓	✓	✓
		1920×1080	H	✓	✓	✓	✓	✓	✓	✓	✓	✓
			M	✓	✓	✓	✓	✓	✓	✓	✓	✓
			L	✓	✓	✓	✓	✓	✓	✓	✓	✓
	XAVC S Intra 422	3840×2160	H	x	x	x	x	x	x	✓	✓	✓
			M	x	x	x	x	x	x	✓	✓	✓
			L	x	x	x	x	x	x	✓	✓	✓
		1920×1080	H	x	x	x	x	x	x	✓	✓	✓
			M	x	x	x	x	x	x	✓	✓	✓
			L	x	x	x	x	x	x	✓	✓	✓

Recording format			[Bit Rate]	SDXC							CFexpress Type A	
System frequency	[Codec]	Resolution		Class 10	U1	U3	VSC V10	VSC V30	VSC V60	VSC V90	CFE200	CFE400
50 Hz	XAVC HS Long 422	3840×2160	H	x	x	✓	x	✓	✓	✓	✓	✓
			M	x	x	✓	x	✓	✓	✓	✓	✓
			L	x	x	✓	x	✓	✓	✓	✓	✓
	XAVC HS Long 420	3840×2160	H	x	x	✓	x	✓	✓	✓	✓	✓
			M	x	x	✓	x	✓	✓	✓	✓	✓
			L	✓	✓	✓	✓	✓	✓	✓	✓	✓
	XAVC S Long 422	3840×2160	H	x	x	✓	x	✓	✓	✓	✓	✓
			M	x	x	✓	x	✓	✓	✓	✓	✓
			L	x	x	✓	x	✓	✓	✓	✓	✓
		1920×1080	H	✓	✓	✓	✓	✓	✓	✓	✓	✓
			M	✓	✓	✓	✓	✓	✓	✓	✓	✓
			L	✓	✓	✓	✓	✓	✓	✓	✓	✓
	XAVC S Long 420	3840×2160	H	x	x	✓	x	✓	✓	✓	✓	✓
			M	x	x	✓	x	✓	✓	✓	✓	✓
			L	x	x	✓	x	✓	✓	✓	✓	✓
		1920×1080	H	✓	✓	✓	✓	✓	✓	✓	✓	✓
			M	✓	✓	✓	✓	✓	✓	✓	✓	✓
			L	✓	✓	✓	✓	✓	✓	✓	✓	✓
	XAVC S Intra 422	3840×2160	H	x	x	x	x	x	x	✓	✓	✓
			M	x	x	x	x	x	x	✓	✓	✓
			L	x	x	x	x	x	x	✓	✓	✓
		1920×1080	H	x	x	x	x	x	x	✓	✓	✓
			M	x	x	x	x	x	x	✓	✓	✓
			L	x	x	x	x	x	x	✓	✓	✓

Recording format			[Bit Rate]	SDXC							CFexpress Type A		
System frequency	[Codec]	Resolution		Class 10	U1	U3	VSC V10	VSC V30	VSC V60	VSC V90	CFE200	CFE400	
29.97 Hz	XAVC S Long 422	3840×2160	H	x	x	✓	x	✓	✓	✓	✓	✓	
			M	x	x	✓	x	✓	✓	✓	✓	✓	
			L	x	x	✓	x	✓	✓	✓	✓	✓	
		1920×1080	H	✓	✓	✓	✓	✓	✓	✓	✓	✓	✓
			M	✓	✓	✓	✓	✓	✓	✓	✓	✓	✓
			L	✓	✓	✓	✓	✓	✓	✓	✓	✓	✓
	XAVC S Long 420	3840×2160	H	x	x	✓	x	✓	✓	✓	✓	✓	
			M	✓	✓	✓	✓	✓	✓	✓	✓	✓	
			L	✓	✓	✓	✓	✓	✓	✓	✓	✓	
		1920×1080	H	✓	✓	✓	✓	✓	✓	✓	✓	✓	✓
			M	✓	✓	✓	✓	✓	✓	✓	✓	✓	✓
			L	✓	✓	✓	✓	✓	✓	✓	✓	✓	✓
	XAVC S Intra 422	3840×2160	H	x	x	x	x	x	x	✓	✓	✓	
			M	x	x	x	x	x	x	✓	✓	✓	
			L	x	x	x	x	x	x	✓	✓	✓	
		1920×1080	H	x	x	x	x	x	x	✓	✓	✓	
			M	x	x	x	x	x	x	✓	✓	✓	
			L	x	x	x	x	x	x	✓	✓	✓	

Recording format			[Bit Rate]	SDXC							CFexpress Type A		
System frequency	[Codec]	Resolution		Class 10	U1	U3	VSC V10	VSC V30	VSC V60	VSC V90	CFE200	CFE400	
25 Hz	XAVC S Long 422	3840×2160	H	x	x	✓	x	✓	✓	✓	✓	✓	
			M	x	x	✓	x	✓	✓	✓	✓	✓	
			L	x	x	✓	x	✓	✓	✓	✓	✓	
		1920×1080	H	✓	✓	✓	✓	✓	✓	✓	✓	✓	✓
			M	✓	✓	✓	✓	✓	✓	✓	✓	✓	✓
			L	✓	✓	✓	✓	✓	✓	✓	✓	✓	✓
	XAVC S Long 420	3840×2160	H	x	x	✓	x	✓	✓	✓	✓	✓	
			M	✓	✓	✓	✓	✓	✓	✓	✓	✓	
			L	✓	✓	✓	✓	✓	✓	✓	✓	✓	
		1920×1080	H	✓	✓	✓	✓	✓	✓	✓	✓	✓	✓
			M	✓	✓	✓	✓	✓	✓	✓	✓	✓	✓
			L	✓	✓	✓	✓	✓	✓	✓	✓	✓	✓
	XAVC S Intra 422	3840×2160	H	x	x	x	x	x	x	✓	✓	✓	
			M	x	x	x	x	x	x	✓	✓	✓	
			L	x	x	x	x	x	x	✓	✓	✓	
		1920×1080	H	x	x	x	x	x	x	✓	✓	✓	
			M	x	x	x	x	x	x	✓	✓	✓	
			L	x	x	x	x	x	x	✓	✓	✓	

Recording format			[Bit Rate]	SDXC								CFexpress Type A	
System frequency	[Codec]	Resolution		Class 10	U1	U3	VSC V10	VSC V30	VSC V60	VSC V90	CFE200	CFE400	
23.98 Hz	XAVC HS Long 422	3840×2160	H	x	x	✓	x	✓	✓	✓	✓	✓	
			M	✓	✓	✓	✓	✓	✓	✓	✓	✓	
			L	✓	✓	✓	✓	✓	✓	✓	✓	✓	
	XAVC HS Long 420	3840×2160	H	x	x	✓	x	✓	✓	✓	✓	✓	
			M	✓	✓	✓	✓	✓	✓	✓	✓	✓	
			L	✓	✓	✓	✓	✓	✓	✓	✓	✓	
	XAVC S Long 422	3840×2160	H	x	x	✓	x	✓	✓	✓	✓	✓	
			M	x	x	✓	x	✓	✓	✓	✓	✓	
			L	x	x	✓	x	✓	✓	✓	✓	✓	
		1920×1080	H	✓	✓	✓	✓	✓	✓	✓	✓	✓	
			M	✓	✓	✓	✓	✓	✓	✓	✓	✓	
			L	✓	✓	✓	✓	✓	✓	✓	✓	✓	
	XAVC S Long 420	3840×2160	H	x	x	✓	x	✓	✓	✓	✓	✓	
			M	✓	✓	✓	✓	✓	✓	✓	✓	✓	
			L	✓	✓	✓	✓	✓	✓	✓	✓	✓	
		1920×1080	H	✓	✓	✓	✓	✓	✓	✓	✓	✓	
			M	✓	✓	✓	✓	✓	✓	✓	✓	✓	
			L	✓	✓	✓	✓	✓	✓	✓	✓	✓	
	XAVC S Intra 422	3840×2160	H	x	x	x	x	x	x	✓	✓	✓	
			M	x	x	x	x	x	x	✓	✓	✓	
			L	x	x	x	x	x	x	✓	✓	✓	
		1920×1080	H	x	x	x	x	x	x	✓	✓	✓	
			M	x	x	x	x	x	x	✓	✓	✓	
			L	x	x	x	x	x	x	✓	✓	✓	

S&Q

- ✓ : Operation guaranteed
- ✗ : Operation not guaranteed

Recording format			S&Q shooting frame rate	[Bit Rate]	SDXC							CFexpress Type A		
System frequency	[Codec]	Resolution			Class 10	U1	U3	VSC V10	VSC V30	VSC V60	VSC V90	CFE200	CFE400	
59.94 Hz	XAVC HS Long 422	3840×2160	1–60	H	x	x	x	x	x	✓	✓	✓	✓	
				M, L	x	x	x	x	x	✓	✓	✓	✓	
			100, 120	H	x	x	x	x	x	x	✓	✓	✓	✓
				M, L	x	x	x	x	x	x	✓	✓	✓	✓
	XAVC HS Long 420	3840×2160	1–60	H	x	x	x	x	x	✓	✓	✓	✓	
				M	x	x	x	x	x	✓	✓	✓	✓	
				L	x	x	x	x	x	✓	✓	✓	✓	
			100, 120	H	x	x	x	x	x	✓	✓	✓	✓	
				M	x	x	x	x	x	✓	✓	✓	✓	
				L	x	x	x	x	x	✓	✓	✓	✓	
	XAVC S Long 422	3840×2160	1–60	H, M, L	x	x	x	x	x	✓	✓	✓	✓	
			100, 120	H, M, L	x	x	x	x	x	x	✓	✓	✓	
1920×1080		1–60	H, M, L	x	x	✓	x	✓	✓	✓	✓	✓		
		100, 120	H, M, L	x	x	✓	x	✓	✓	✓	✓	✓		
		150, 180, 200, 240	H, M, L	x	x	x	x	x	✓	✓	✓	✓		
			H, M, L	x	x	x	x	x	✓	✓	✓	✓		
XAVC S Long 420	3840×2160	1–60	H, M, L	x	x	x	x	x	✓	✓	✓	✓		
		100, 120	H, M, L	x	x	x	x	x	✓	✓	✓	✓		
	1920×1080	1–60	H	x	x	✓	x	✓	✓	✓	✓	✓		
			M, L	x	x	✓	x	✓	✓	✓	✓	✓		
	150, 180, 200, 240	100, 120	H	x	x	✓	x	✓	✓	✓	✓	✓		
			M, L	x	x	✓	x	✓	✓	✓	✓	✓		
		H	x	x	x	x	x	✓	✓	✓	✓			
			M, L	x	x	✓	x	✓	✓	✓	✓			

Recording format			S&Q shooting frame rate	[Bit Rate]	SDXC							CFexpress Type A	
System frequency	[Codec]	Resolution			Class 10	U1	U3	VSC V10	VSC V30	VSC V60	VSC V90	CFE200	CFE400
	XAVC S Intra 422	3840×2160	1–60	H, M, L	x	x	x	x	x	x	✓	✓	✓
			100, 120	H, M, L	x	x	x	x	x	x	✓	✓	✓
		1920×1080	1–60	H, M, L	x	x	x	x	x	x	✓	✓	✓
			100, 120	H, M, L	x	x	x	x	x	x	✓	✓	✓

Recording format			S&Q shooting frame rate	[Bit Rate]	SDXC							CFexpress Type A		
System frequency	[Codec]	Resolution			Class 10	U1	U3	VSC V10	VSC V30	VSC V60	VSC V90	CFE200	CFE400	
50 Hz	XAVC HS Long 422	3840×2160	1–60	H	x	x	x	x	x	✓	✓	✓	✓	
				M, L	x	x	x	x	x	✓	✓	✓	✓	
			100, 120	H	x	x	x	x	x	x	✓	✓	✓	✓
				M, L	x	x	x	x	x	x	✓	✓	✓	✓
	XAVC HS Long 420	3840×2160	1–60	H	x	x	x	x	x	✓	✓	✓	✓	
				M	x	x	x	x	x	✓	✓	✓	✓	
				L	x	x	x	x	x	✓	✓	✓	✓	
			100, 120	H	x	x	x	x	x	✓	✓	✓	✓	
				M	x	x	x	x	x	✓	✓	✓	✓	
				L	x	x	x	x	x	✓	✓	✓	✓	
	XAVC S Long 422	3840×2160	1–60	H, M, L	x	x	x	x	x	✓	✓	✓	✓	
			100, 120	H, M, L	x	x	x	x	x	x	✓	✓	✓	
		1920×1080	1–60	H, M, L	x	x	✓	x	✓	✓	✓	✓	✓	
			100, 120	H, M, L	x	x	✓	x	✓	✓	✓	✓	✓	
			150, 180, 200, 240	H, M, L	x	x	x	x	x	✓	✓	✓	✓	
				H, M, L	x	x	x	x	x	✓	✓	✓	✓	
	XAVC S Long 420	3840×2160	1–60	H, M, L	x	x	x	x	x	✓	✓	✓	✓	
			100, 120	H, M, L	x	x	x	x	x	✓	✓	✓	✓	
1920×1080		1–60	H	x	x	✓	x	✓	✓	✓	✓	✓		
			M, L	x	x	✓	x	✓	✓	✓	✓	✓		
100, 120		H	x	x	✓	x	✓	✓	✓	✓	✓			
			M, L	x	x	✓	x	✓	✓	✓	✓			
		150, 180, 200, 240	H	x	x	x	x	x	✓	✓	✓			
			M, L	x	x	x	x	x	✓	✓	✓			

Recording format			S&Q shooting frame rate	[Bit Rate]	SDXC							CFexpress Type A	
System frequency	[Codec]	Resolution			Class 10	U1	U3	VSC V10	VSC V30	VSC V60	VSC V90	CFE200	CFE400
29.97 Hz	XAVC S Intra 422	3840×2160	1–60	H, M, L	x	x	x	x	x	x	✓	✓	✓
			100, 120	H, M, L	x	x	x	x	x	x	✓	✓	✓
		1920×1080	1–60	H, M, L	x	x	x	x	x	x	✓	✓	✓
			100, 120	H, M, L	x	x	x	x	x	x	✓	✓	✓
	XAVC S Long 422	3840×2160	1–60	H, M, L	x	x	x	x	x	✓	✓	✓	✓
			100, 120	H, M, L	x	x	x	x	x	x	✓	✓	✓
		1920×1080	1–60	H, M, L	x	x	✓	x	✓	✓	✓	✓	✓
			100, 120	H, M, L	x	x	x	x	x	✓	✓	✓	✓
150, 180, 200, 240			H, M, L	x	x	x	x	x	x	✓	✓	✓	
XAVC S Long 420	3840×2160	1–60	H	x	x	x	x	x	✓	✓	✓	✓	
			M, L	x	x	x	x	x	✓	✓	✓	✓	
		100, 120	H	x	x	x	x	x	x	✓	✓	✓	
			M, L	x	x	x	x	x	x	✓	✓	✓	✓
	1920×1080	1–60	H	x	x	✓	x	✓	✓	✓	✓	✓	
			M, L	x	x	✓	x	✓	✓	✓	✓	✓	
		100, 120	H	x	x	x	x	x	✓	✓	✓	✓	
			M, L	x	x	✓	x	✓	✓	✓	✓	✓	
	150, 180, 200, 240	H	x	x	x	x	x	x	✓	✓	✓		
		M, L	x	x	x	x	x	✓	✓	✓	✓		
	XAVC S Intra 422	3840×2160	1–60	H, M, L	x	x	x	x	x	x	✓	✓	✓
			120	H, M, L	x	x	x	x	x	x	✓	✓	
1920×1080		1–60	H, M, L	x	x	x	x	x	x	✓	✓	✓	
		120	H, M, L	x	x	x	x	x	x	✓	✓	✓	

Recording format			S&Q shooting frame rate	[Bit Rate]	SDXC							CFexpress Type A			
System frequency	[Codec]	Resolution			Class 10	U1	U3	VSC V10	VSC V30	VSC V60	VSC V90	CFE200	CFE400		
25 Hz	XAVC S Long 422	3840×2160	1–60	H, M, L	x	x	x	x	x	✓	✓	✓	✓		
			100, 120	H, M, L	x	x	x	x	x	x	✓	✓	✓		
		1920×1080	1–60	H, M, L	x	x	✓	x	✓	✓	✓	✓	✓	✓	
			100, 120	H, M, L	x	x	x	x	x	x	✓	✓	✓	✓	
			150, 180, 200, 240	H, M, L	x	x	x	x	x	x	x	✓	✓	✓	
		XAVC S Long 420	3840×2160	1–60	H	x	x	x	x	x	x	✓	✓	✓	✓
					M, L	x	x	x	x	x	x	✓	✓	✓	✓
				100, 120	H	x	x	x	x	x	x	x	✓	✓	✓
					M, L	x	x	x	x	x	x	x	✓	✓	✓
	1920×1080		1–60	H	x	x	✓	x	✓	✓	✓	✓	✓	✓	
				M, L	x	x	✓	x	✓	✓	✓	✓	✓	✓	
			100, 120	H	x	x	x	x	x	x	✓	✓	✓	✓	
				M, L	x	x	✓	x	✓	✓	✓	✓	✓	✓	
	150, 180, 200, 240		H	x	x	x	x	x	x	x	✓	✓	✓		
			M, L	x	x	x	x	x	x	✓	✓	✓	✓		
	XAVC S Intra 422		3840×2160	1–60	H, M, L	x	x	x	x	x	x	x	✓	✓	✓
				100	H, M, L	x	x	x	x	x	x	x	x	✓	✓
		1920×1080	1–60	H, M, L	x	x	x	x	x	x	x	✓	✓	✓	
			100	H, M, L	x	x	x	x	x	x	x	✓	✓	✓	

Recording format			S&Q shooting frame rate	[Bit Rate]	SDXC							CFexpress Type A		
System frequency	[Codec]	Resolution			Class 10	U1	U3	VSC V10	VSC V30	VSC V60	VSC V90	CFE200	CFE400	
23.98 Hz	XAVC HS Long 422	3840×2160	1–60	H	x	x	x	x	x	✓	✓	✓	✓	
				M, L	x	x	x	x	x	✓	✓	✓	✓	
			100, 120	H	x	x	x	x	x	x	✓	✓	✓	✓
				M, L	x	x	x	x	x	✓	✓	✓	✓	✓
	XAVC HS Long 420	3840×2160	1–60	H	x	x	x	x	x	✓	✓	✓	✓	
				M	x	x	x	x	x	✓	✓	✓	✓	
				L	x	x	x	x	x	✓	✓	✓	✓	
			100, 120	H	x	x	x	x	x	x	✓	✓	✓	✓
				M	x	x	x	x	x	✓	✓	✓	✓	✓
				L	x	x	x	x	x	✓	✓	✓	✓	✓
	XAVC S Long 422	3840×2160	1–60	H, M, L	x	x	x	x	x	✓	✓	✓	✓	
			100, 120	H, M, L	x	x	x	x	x	x	✓	✓	✓	
		1920×1080	1–60	H, M, L	x	x	✓	x	✓	✓	✓	✓	✓	
			100, 120	H, M, L	x	x	x	x	x	✓	✓	✓	✓	
			150, 180, 200, 240	H, M, L	x	x	x	x	x	x	✓	✓	✓	
	XAVC S Long 420	3840×2160	1–60	H	x	x	x	x	x	✓	✓	✓	✓	
				M, L	x	x	x	x	x	✓	✓	✓	✓	
100, 120			H	x	x	x	x	x	x	✓	✓	✓		
			M, L	x	x	x	x	x	✓	✓	✓	✓		
1920×1080		1–60	H, M, L	x	x	✓	x	✓	✓	✓	✓	✓		
		100, 120	H, M, L	x	x	x	x	x	✓	✓	✓	✓		
		150, 180, 200, 240	H, M, L	x	x	x	x	x	x	✓	✓	✓		

Recording format			S&Q shooting frame rate	[Bit Rate]	SDXC							CFexpress Type A	
System frequency	[Codec]	Resolution			Class 10	U1	U3	VSC V10	VSC V30	VSC V60	VSC V90	CFE200	CFE400
	XAVC S Intra 422	3840×2160	1–60	H, M, L	x	x	x	x	x	x	✓	✓	✓
			120	H, M, L	x	x	x	x	x	x	✓	✓	✓
		1920×1080	1–60	H, M, L	x	x	x	x	x	x	✓	✓	✓
			120	H, M, L	x	x	x	x	x	x	✓	✓	✓

TP1001804481

Color Video Camera
BRC-AM7

Inserting Memory Cards

This topic describes the precautions when inserting memory cards.

1 Open the media cover of the card slot section.

2 Insert a memory card.

For CFexpress cards, the label faces up.

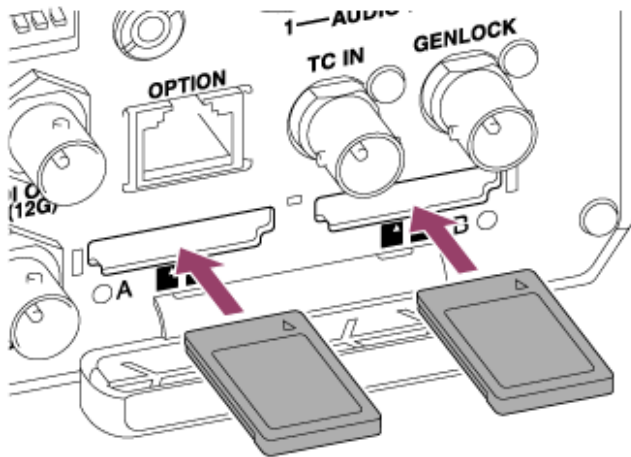

Note

- On a ceiling mounted unit, the label faces down.

For SD cards, the label faces down.

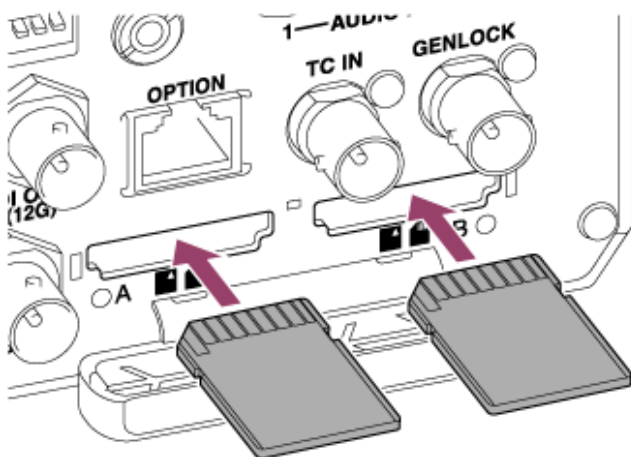

Note

- On a ceiling mounted unit, the label faces up.

The access indicator is lit red, then changes to green if the card is usable.

Note

- If the access indicator blinks red continuously and does not change to green, temporarily turn off the unit, and remove and reinsert the memory card.

3 Close the media cover.

Note

- The memory card, memory card slot, and image data on the memory card may be damaged if the card is forced into the slot in the incorrect orientation.
- When recording to media inserted in both CFexpress Type A/SD card slots A and B, insert media in both slots that is recommended for the format of the recording.

TP1001804482

5-065-326-11(1) Copyright 2024 Sony Corporation

Color Video Camera
BRC-AM7

Ejecting a Memory Card

Open the media cover of the card slot section, and lightly press the memory card in to eject the card.

Note

- If the unit is turned off or the memory card is removed while the memory card is being accessed, the integrity of data on the card cannot be guaranteed. All data recorded on the card may be discarded. Always make sure the access indicator of the memory card slot is green or off before turning off the unit or removing the memory card.
- When removing a memory card immediately after recording is finished, the memory card may be hot, but this does not indicate a problem.

TP1001804483

Color Video Camera
BRC-AM7

Formatting (Initializing) Memory Cards

If an unformatted memory card or a memory card that was formatted in a different specification is inserted, the message "Media Needs to be Formatted" is displayed in the camera image panel. Format the card using the following procedure.

- 1 Select [TC/Media] – [Format Media] in the camera menu.**
- 2 Select Media(A) (slot A) or Media(B) (slot B), then select the formatting method ([Full Format] or [Quick Format]).**

A confirmation message appears.
[Full Format]: Initializes the media completely, including the data region and data management information.
[Quick Format]: Initializes the data management information of the media only.
- 3 Select [Execute].**

A message is displayed while formatting is in progress, and the access indicator is lit red.
When formatting ends, a completion message appears.

Note

- Formatting a memory card erases all data, including recorded video data and setup files.
- Messages may appear during execution depending on the formatting process duration.

If formatting fails

Memory cards not supported by the unit cannot be formatted.
A warning message is displayed. Follow the instructions to replace the card with a supported memory card.

To use a card formatted on the unit in the slot of another device

First, make a backup of the card, then reformat the card in the device to be used.

TP1001804484

Color Video Camera
BRC-AM7

Checking the Remaining Recording Time

When shooting (recording/standby), you can monitor the remaining capacity of the memory card in each slot using the slot A/B remaining media indicators in the camera image panel.

The remaining recording time is calculated from the remaining capacity of the media in each slot and the current recording format (recording bit rate), and is displayed in units of minutes.

Memory card replacement timing

When the total remaining recording time on the two memory cards becomes less than 5 minutes, the message [Media Near Full] appears and the recording/tally lamp starts blinking to warn you.

Replace with media that has free space.

If you continue recording until the total remaining recording time reaches zero, the message changes to [Media Full] and recording stops.

Note

- Up to approximately 9999 clips can be recorded on one memory card.

TP1001804485

Color Video Camera
BRC-AM7

Restoring Memory Cards

If for any reason an error should occur in a memory card, the card must be restored before use.

When you load a memory card that needs to be restored, a message appears in the camera image panel asking whether you want to restore it.

To restore a card

Select [Execute] using the arrow buttons in the GUI control panel and press the [Set] button.

A message and progress status (%) are displayed while formatting is in progress, and the access indicator is lit red.

When restoration ends, a completion message appears.

If restoration fails

- Memory cards on which memory errors have occurred cannot be restored. A warning message is displayed. Follow the instructions to replace the memory card.
- Memory cards on which memory errors have occurred may become usable if they are reformatted.
- In some cases, some clips can be restored while others cannot. The restored clips can be played normally.

Note

- For restoration of media recorded with this unit, be sure to use this unit.
- Media recorded with a device other than this unit or with another unit of different version (even of the same model) may not be restored using this unit.
- Clips shorter than 2 seconds cannot be restored.

TP1001804486

Starting/Stopping Recording

This topic describes how to start/stop recording.

- 1 **Attach the necessary devices, and check that power of the unit and peripheral devices is being supplied.**

Note

- Recording is not supported when using a PoE++ power supply.

- 2 **Insert the memory card(s).**

- 3 **Check the power status of the unit at the top left of the Web App screen.**

When power supply is on

When the power to the unit is turned on, the live operation screen, playback operation screen, or web menu is displayed in the Web App.

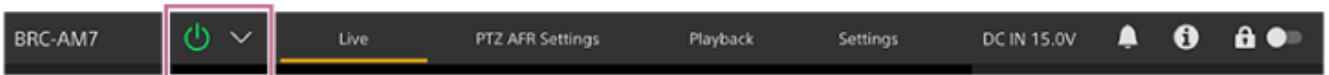

The POWER lamp lights up on the front of the unit and the camera image appears on the live operation screen of the Web App.

Note

- If the administrator password has not been configured, a screen prompting you to configure the password appears. See "Initializing the Unit."

When power supply is in standby state

When the power supply of the unit is in standby state, a message is displayed in the Web App indicating the power supply is in standby state.



Press the power switch and select [Power ON] in the switch menu. The unit turns on, the POWER lamp lights up green on the front of the unit, and the camera image appears on the live operation screen of the Web App.

Hint

- You can also turn on the unit using the power button on the supplied infrared remote control.

4 Press the record START/STOP button.

Recording starts, and the recording/tally lamp (2 places) of the unit lights up.

During recording, the record START/STOP button lights. Also, an icon for the target recording media and [●Rec] are displayed.

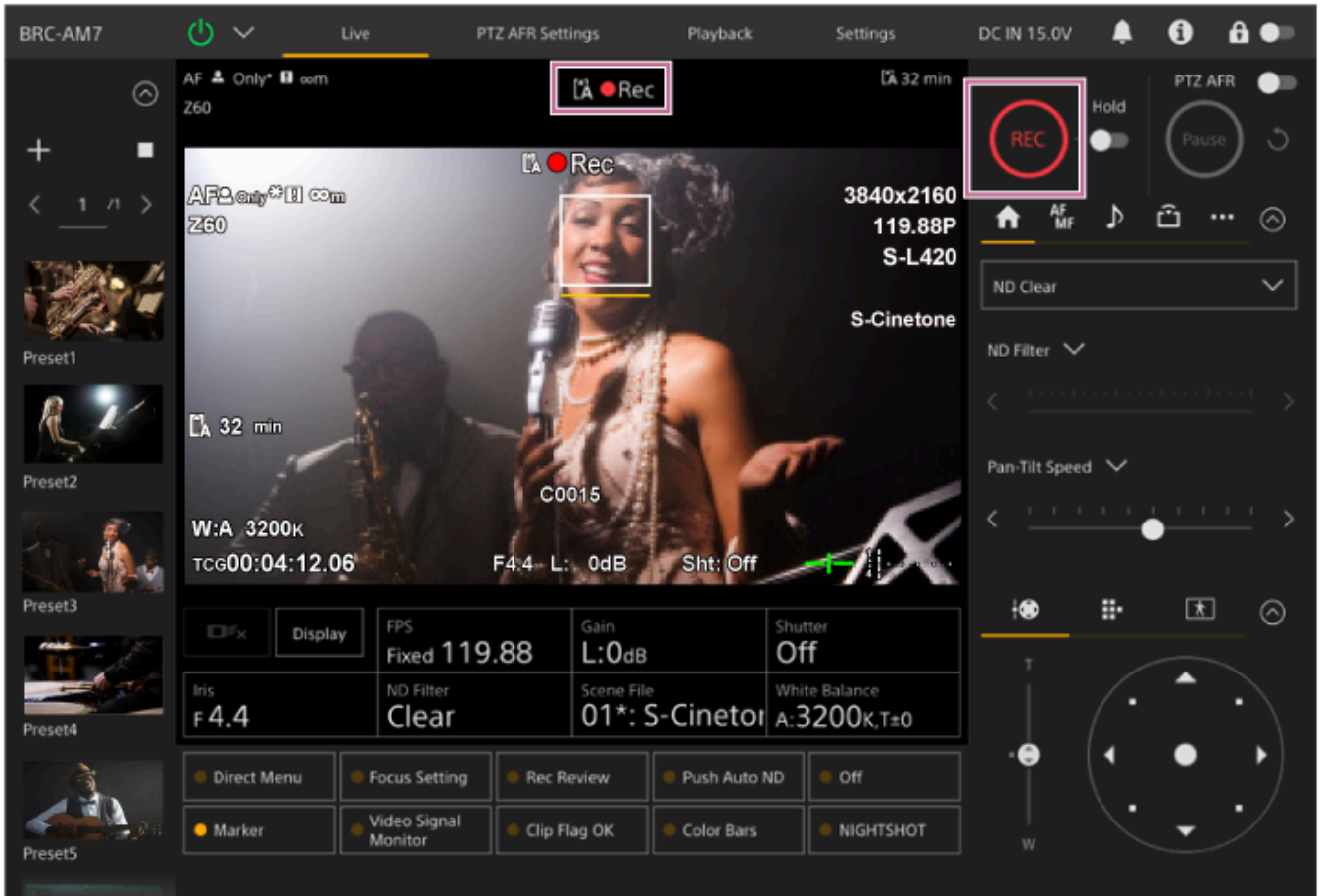

5 To stop recording, press the record START/STOP button again.

Recording stops, and the recording/tally lamp (2 places) of the unit turns off.

During recording standby state, the record START/STOP button is not lit. Also, an icon for the target recording media and [Stby] are displayed.

Hint

- You can also start/stop recording using the record START/STOP button on the supplied infrared remote control.

To switch the power supply of the unit to standby state

Press the power switch in the Web App and select [Power Standby] in the switch menu to set the power supply of the unit to standby state.

Hint

- You can also set the power supply to standby state using the power button on the supplied infrared remote control.

Related Topic

- [Initializing the Unit](#)

TP1001804487

5-065-326-11(1) Copyright 2024 Sony Corporation

Color Video Camera
BRC-AM7

Switching Between Memory Cards

When two memory cards are inserted, you can press the [Slot Select] button on the playback control panel of the Web App to switch memory cards.

Hint

- You can also press the SLOT SEL (memory card slot (A)/(B) select) button on the supplied infrared remote control to switch memory cards.

About relay recording

When recording, the unit automatically switches to the second memory card just before the remaining capacity on the first card is reduced to zero (relay recording). You can continue recording continuously when switching memory cards by replacing the memory card that is full with a new memory card.

Note

- You cannot switch between memory cards during playback mode. Also, continuous playback of a clip spanning media in slot A and slot B is not supported.

About recorded data

When you stop recording, the video, audio, and accompanying data from the start to the end of the recording are saved as a single “clip” on a memory card.

Clip name of recorded data

The name of each clip recorded by the unit is automatically assigned using [TC/Media] – [Clip Name Format] in the camera menu.

Maximum clip duration

Up to 6 hours per clip.

The maximum duration of continuous recording is the same as the maximum duration of a clip. If the recording time exceeds the maximum duration of a clip, a new clip is created automatically and recording continues. The new clip appears as a separate clip on the thumbnail screen.

Multiple clips are recorded in succession during relay recording, but recording will stop automatically after approximately 24 hours.

Note

- Do not eject a memory card while recording to it is in progress. When recording, only change memory cards in slots for which the slot access indicator is off.
- When the remaining capacity on the memory card being recorded becomes less than one minute and a recordable memory card is inserted in the other slot, a “Will Switch Slots Soon” message appears. The message disappears after switching memory card slots.
- Relay recording may not operate if recording is started when the remaining memory card capacity is less than one minute. For correct relay recording, check that the remaining memory card capacity is more than one minute before starting recording.
- Video created using the relay recording function of the unit cannot be played back seamlessly on the unit.
- To combine video created using the relay recording function of the unit, use “Catalyst Browse” software.

Color Video Camera
BRC-AM7

Checking the Audio

Audio is output from SDI / HDMI / Stream of the unit. Select the combination of audio channels that are output from SDI2 and HDMI using [Audio] – [Audio Output] – [SDI2/HDMI/Strm Out CH] in the camera menu.

[CH1/CH2]: CH1 and CH2 combination

[CH3/CH4]: CH3 and CH4 combination

When checking the audio in the Web App, use the audio level meter at the bottom right of the camera image.

TP1001804489

Color Video Camera
BRC-AM7

Specifying Time Data

This topic describes how to set time data.

Setting the timecode

Set the timecode to record using [TC/Media] – [Timecode] in the camera menu.

Setting user bits

You can add an 8-digit hexadecimal number to the recorded image as user bits. You can also set the user bits to the current time. Set using [TC/Media] – [Users Bit] in the camera menu.

Displaying time data

Set the timecode to display using [TC/Media] – [TC Display] – [Display Select] in the camera menu.

Pressing an assignable button with [DURATION/TC/U-BIT] assigned will switch the display between the timecode, user bits, and duration in sequence.

TP1001804490

Color Video Camera
BRC-AM7

Reviewing the Recording (Rec Review)

You can review the last recorded clip on the screen (recording review).

Note

- Rec Review is not supported if the video format is changed after recording a clip.

Setting the Rec Review start position

You can set the playback start position to one of the following using [Technical] – [Rec Review] in the camera menu.

- Last 3 seconds of the clip
- Last 10 seconds of the clip
- Start of the clip

Hint

- If you want to review a specific clip after recording multiple clips, press the [Thumbnail] button to display the thumbnail screen, and select the clip to start playback.
- You can also press the THUMBNAIL button of the supplied infrared remote control to display the thumbnail screen.
- Playback operations, such as fast forward, are supported in Rec Review mode. For details, see “Playing Recorded Clips.”

Rec Review method

Assign the Rec Review function to one of the assignable buttons on the basic configuration adjustment panel beforehand.

- For details about assignment, see “Assignable Buttons” in “Useful Functions.”

Stop recording and then press an assignable button assigned with the Rec Review function to start playback of the previously recorded clip.

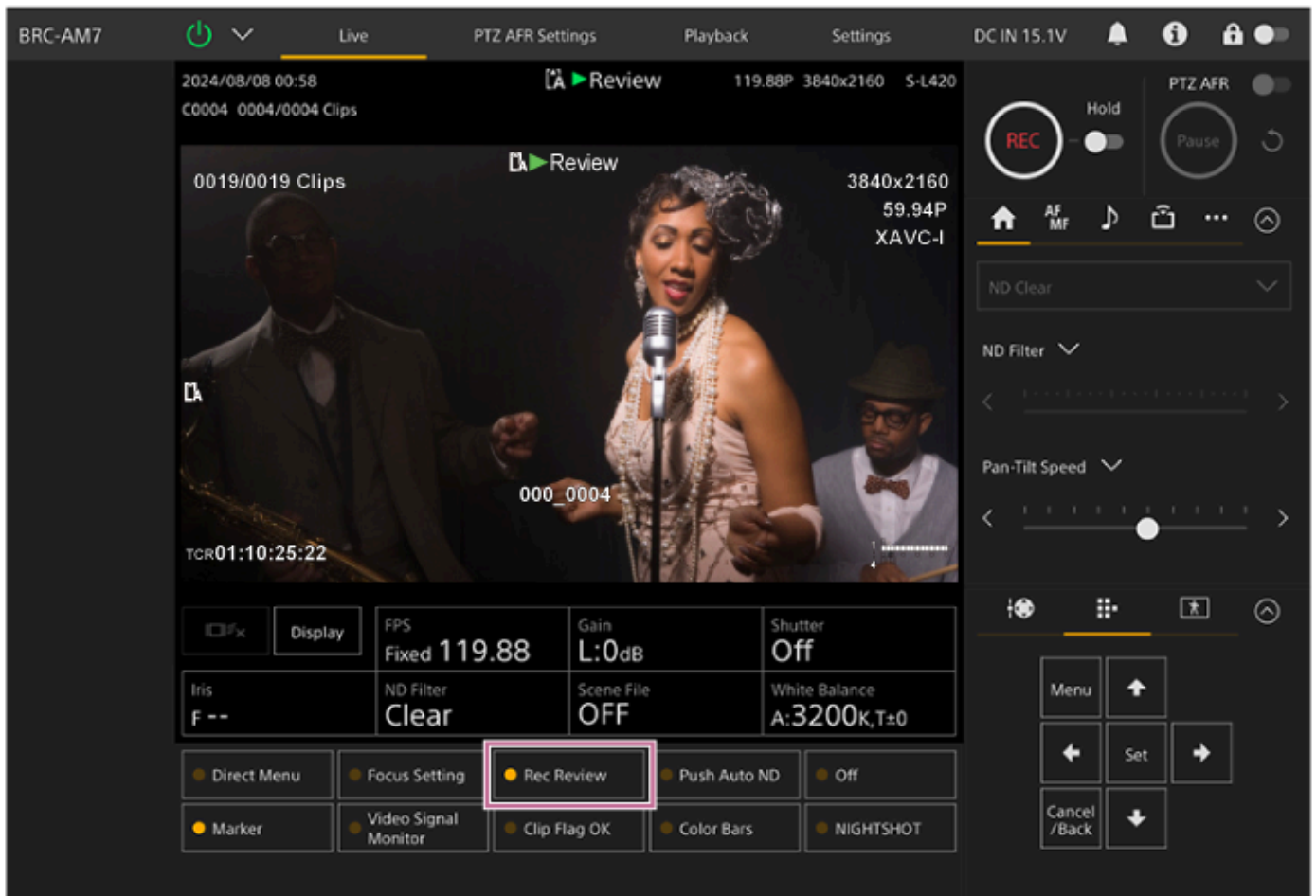

The clip is played to the end, Rec Review ends, and the unit returns to Stby (recording standby) state.

To stop Rec Review

Press an assignable button with Rec Review assigned or press the [Cancel/Back] button.

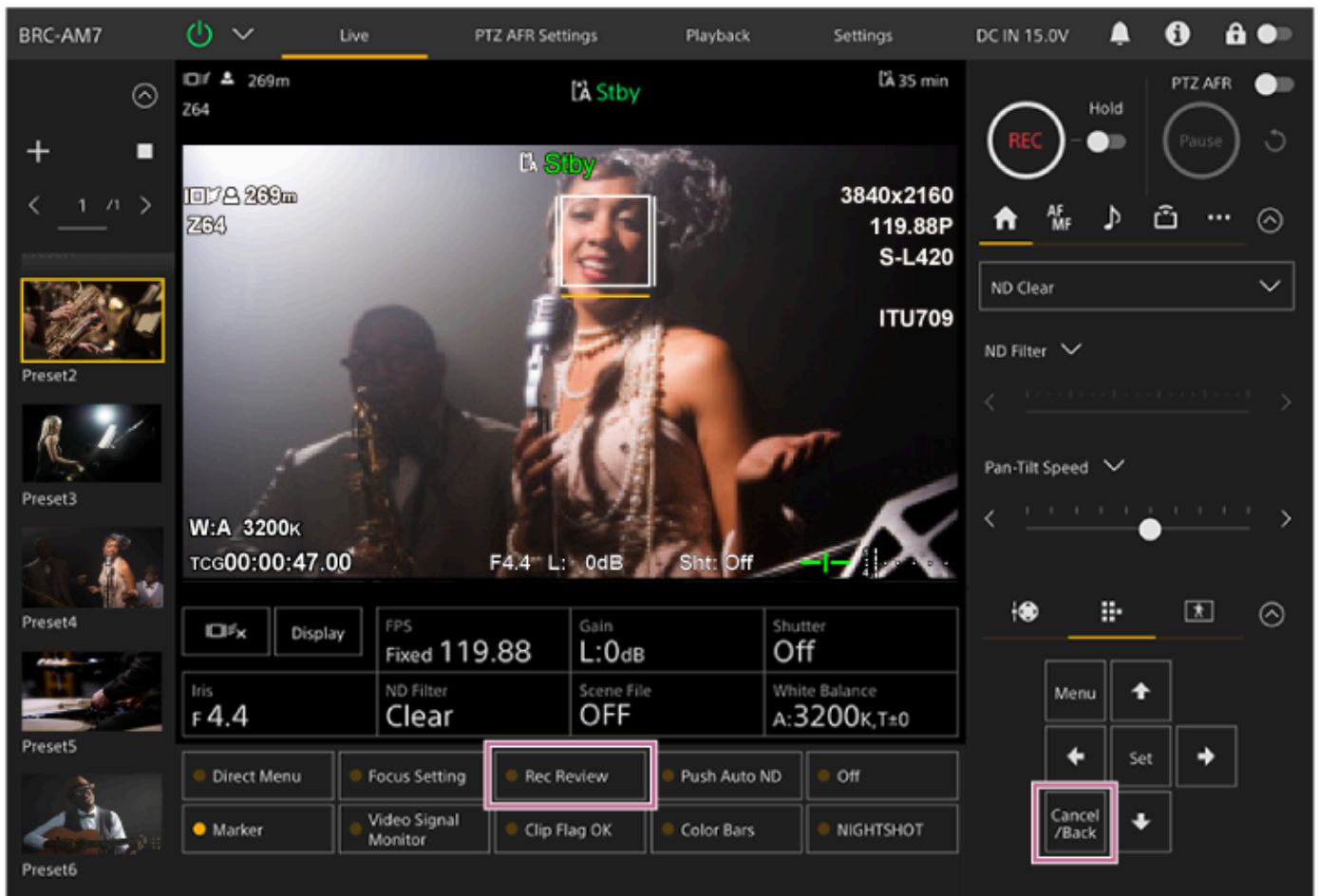

Hint

- You can also press the CANC./ BACK button of the supplied infrared remote control to stop the Rec Review function.

Related Topic

- [Assignable Buttons](#)
- [Playing Recorded Clips](#)

TP1001804491

Framing Adjustment Screen

The framing is adjusted using the following parts of the live operation screen of the Web App.

When PTZ auto framing is off



When PTZ auto framing is on

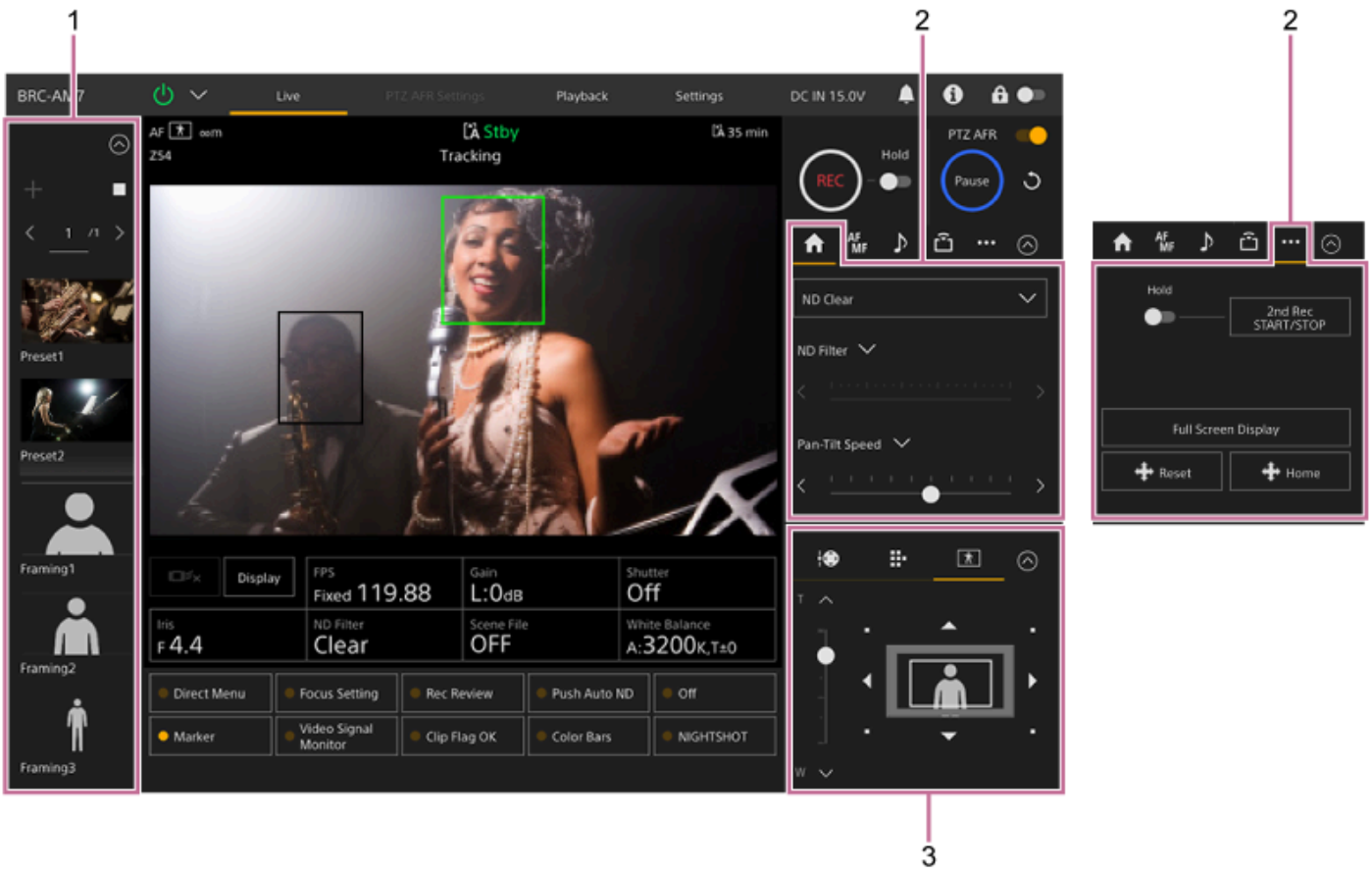

1. Preset position control panel / Composition preset control panel

2. (Main) tab / (Others) tab

3. Framing control panel or AFR composition adjustment panel

Note

- Depending on the direction of the camera and the zoom position, part of the unit or cables connected to the connector block may be visible. Before shooting, check the range that will be captured. You can also control the pan/tilt range using [Pan-Tilt] – [P/T Range Limit] in the web menu. When the unit is turned on or pan/tilt reset is executed, this range limit setting is ignored. For details, see [Pan-Tilt] – [P/T Range Limit] in the web menu.

Hint

- You can also control the framing using the supplied infrared remote control.

TP1001804492

Color Video Camera
BRC-AM7

Adjusting the Shooting Direction Using the Web App

Moving the camera horizontally is called panning, and move the camera vertically is called tilting. You can adjust the shooting direction using pan/tilt operations.

- 1 Press the  (Pan/tilt/zoom) tab in the framing control panel to display the joystick.
- 2 Drag the center of the joystick in the direction you want to view while monitoring the camera image panel.

The direction and speed of the camera changes in response to the drag direction and level. You can adjust the pan/tilt more precisely by pressing the peripheral areas of the joystick.

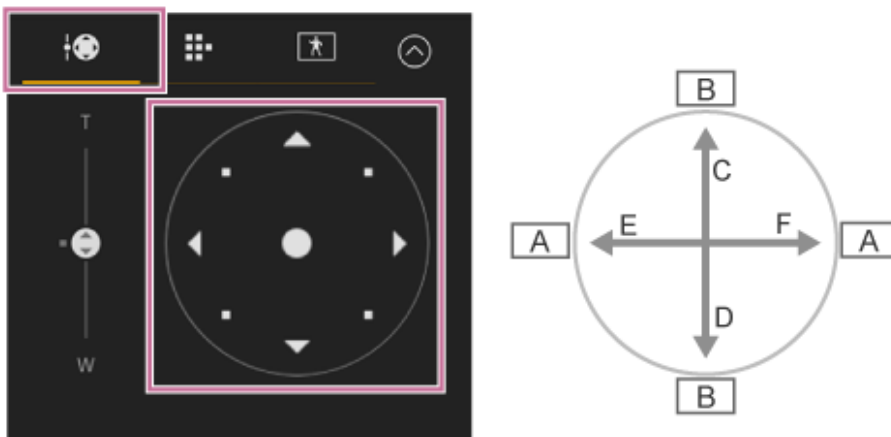



- A: Pan
- B: Tilt
- C: Up
- D: Down
- E: Left
- F: Right

Hint

- If [Execute Pan-Tilt Reset] is displayed below the joystick, an inconsistency has occurred in the pan/tilt control origin information of the unit. Execute the pan/tilt reset function to update the origin information. For details, see "Resetting the Pan/Tilt."

To face the camera back to the front

Press the  (Pan/tilt home) button on the  (Others) tab in the camera control panel.

Note

- Depending on the direction of the camera and the zoom position, part of the unit or cables connected to the connector block may be visible. Before shooting, check the range that will be captured. You can also control the pan/tilt range using [Pan-Tilt] – [P/T Range Limit] in the web menu. When the unit is turned on or pan/tilt reset is executed, this range limit setting is ignored. For details, see [Pan-Tilt] – [P/T Range Limit] in the web menu.

Color Video Camera
BRC-AM7

Setting the Pan/Tilt Operating Speed

You can change the pan/tilt operating speed using the [Pan-Tilt Speed] slider in the camera control panel by operating the joystick in the framing control panel.

1 Press the  (Main) tab in the camera control panel.

2 Select the [Pan-Tilt Speed] slider from the list.

If the [Pan-Tilt Speed] slider is not displayed, select either of the two slider function selection buttons to display the slider.

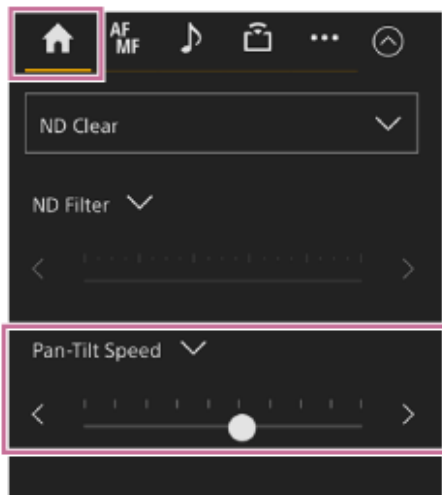

3 Move the slider knob left or right.

Moving the knob to the left decreases the operating speed, while moving the knob to the right increases the operating speed.

Note

- If there is a wall or other obstacle within the range of motion of the camera, be careful not to hit the camera head during pan/tilt operation.
- You can change the pan/tilt acceleration setting using [Pan-Tilt] – [P/T Acceleration] – [Ramp Curve] in the web menu or camera menu.

TP1001804494

Setting the Pan/Tilt Operation Acceleration

You can set the acceleration operation when using the joystick over nine gradations using [Pan-Tilt] – [P/T Acceleration] – [Ramp Curve] in the web menu or camera menu. Increase the value for more rapid changes in speed, or decrease the value for more gradual changes in speed.

For greater responsiveness when operating the pan/tilt, select a value in the range 7 to 9.

Set the preset position acceleration operation using [Pan-Tilt] – [P/T Preset] – [Ramp Curve] in the web menu.

For greater positional accuracy at the start/end of the movement to a preset position, a value in the range 1 to 6 is recommended.

- For details about preset position, see “Saving/Restoring Pan/Tilt and Zoom Position Using the Supplied Infrared Remote Control.”

Relationship between [Ramp Curve] setting and pan/tilt operation

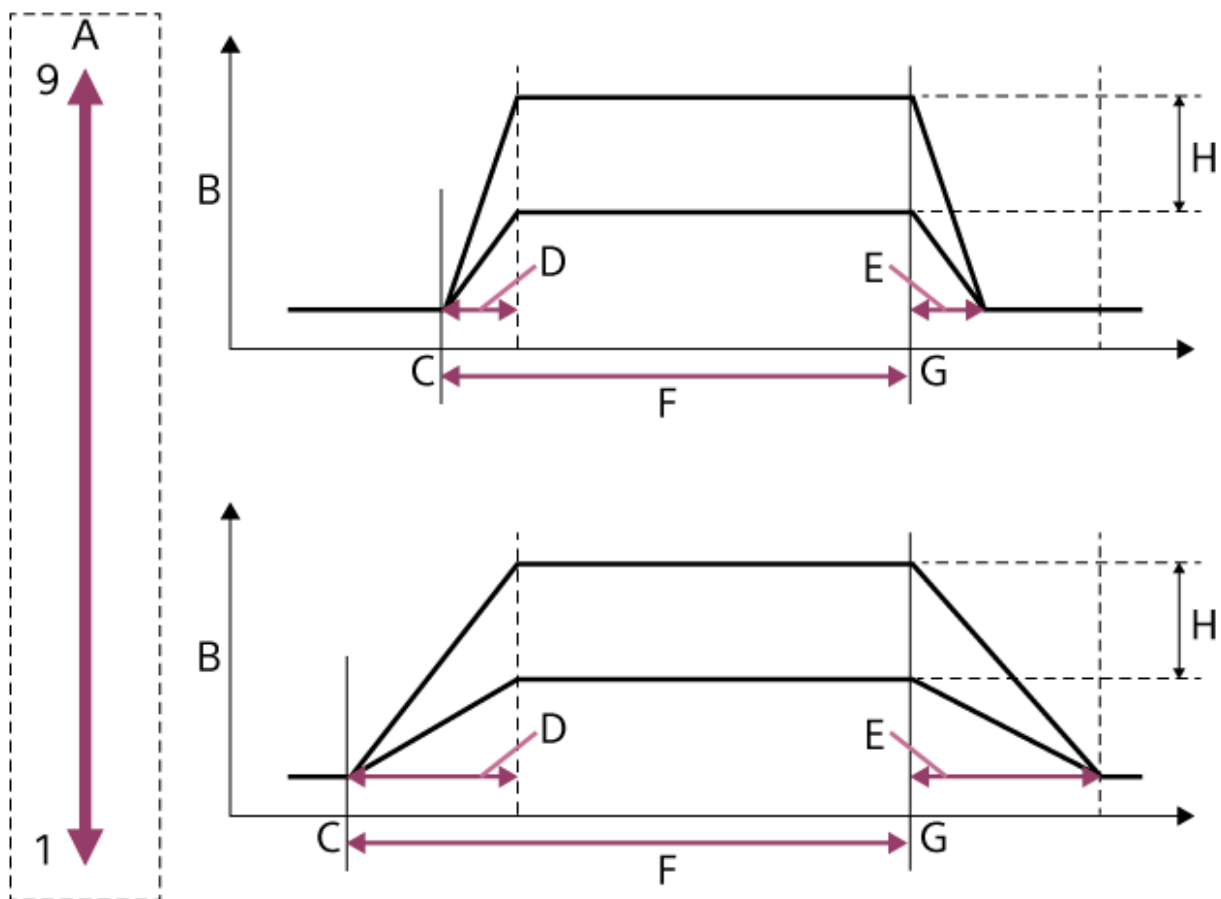

A: [Ramp Curve] setting (fastest (9) to slowest (1))

B: Operating speed

C: Operation start point

D: Acceleration time

E: Deceleration time

F: Operating time

G: Operation end point

H: Maximum speed

Color Video Camera
BRC-AM7

Adjusting the Shooting Direction Using the Supplied Infrared Remote Control





You can adjust the shooting direction using the pan/tilt operation buttons of the supplied infrared remote control.

1 Press the arrow buttons to control the pan/tilt.

Press the arrow button of the direction you want to view while monitoring the camera image.

To move a short distance, press the arrow button briefly.

To move a large distance, press and hold the arrow button.

To move diagonally, press and hold the  (up arrow) or  (down arrow) button and press the  (left arrow) or  (right arrow) button.

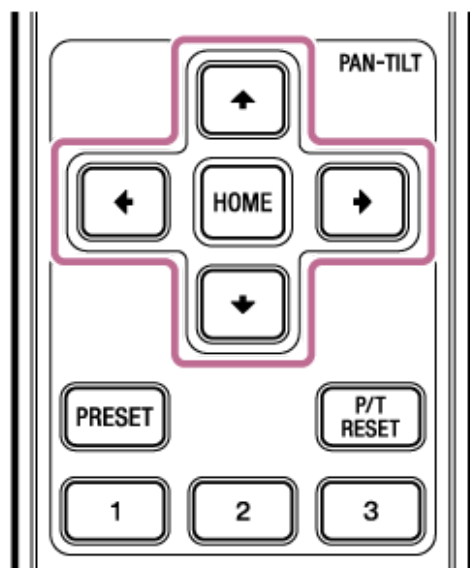

To face the camera back to the front

Press the HOME button.

Note

- Depending on the direction of the camera and the zoom position, part of the unit or cables connected to the connector block may be visible. Before shooting, check the range that will be captured. You can also control the pan/tilt range using [Pan-Tilt] – [P/T Range Limit] in the web menu. When the unit is turned on or pan/tilt reset is executed, this range limit setting is ignored. For details, see [Pan-Tilt] – [P/T Range Limit] in the web menu.

TP1001804496

Color Video Camera
BRC-AM7

Setting the Zoom Type

Set the type of zoom using [Technical] – [Zoom] – [Zoom Type] in the camera menu.

[Optical Zoom Only]: Optical zoom only operation.

[On(Clear Image Zoom)]: Optical zoom and Clear Image Zoom are supported.

Note

- Clear Image Zoom is not available in the following cases.
 - When [Shooting] – [S&Q Motion] – [Setting] is set to [On] in the camera menu and the [Frame Rate] setting is higher than 60fps
 - When [Project] – [Rec Format] – [Frequency] is set to 119.88 or 100 in the web menu or camera menu

Clear Image Zoom

The unit is equipped with a zoom function that uses image signal processing called Clear Image Zoom.

The maximum zoom ratio using Clear Image Zoom varies depending on the recording resolution.

- When the recording resolution is QFHD: 1.5×
- When the recording resolution is HD: 2×

TP1001804497

Color Video Camera
BRC-AM7

Adjusting the Zoom Using the Web App

You can adjust the zoom of the unit using optical zoom or Clear Image Zoom. This topic describes how to make adjustments using the Web App. For details about Clear Image Zoom, see “Setting the Zoom Type.”

- 1 Press the  (Pan/tilt/zoom) tab in the framing control panel to display the pan/tilt control panel.
- 2 Slide the [Zoom] slider knob in the [T] (Telephoto) direction or [W] (Wide) direction to adjust the zoom.

The zoom speed varies with the movement of the slider.

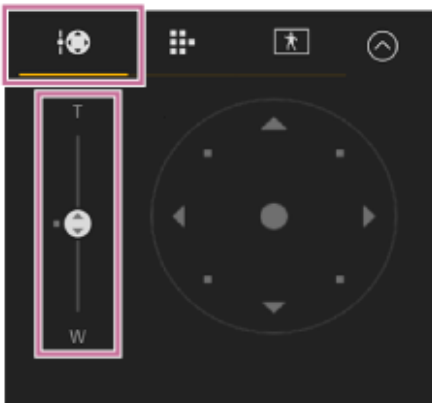

Note

- Depending on the direction of the camera and the zoom position, part of the unit or cables connected to the connector block may be visible. Before shooting, check the range that will be captured. You can also control the pan/tilt range using [Pan-Tilt] – [P/T Range Limit] in the web menu. When the unit is turned on or pan/tilt reset is executed, this range limit setting is ignored. For details, see [Pan-Tilt] – [P/T Range Limit] in the web menu.

Related Topic

- [Setting the Zoom Type](#)

TP1001804498

Color Video Camera
BRC-AM7

Setting the Zoom Operating Speed Using the Web App

You can change the zoom operating speed of the [Zoom] slider in the framing control panel using the [Zoom Speed] slider in the camera control panel.

1 Press the  (Main) tab in the camera control panel.

2 Select the [Zoom Speed] slider from the list.

If the [Zoom Speed] slider is not displayed, select either of the two slider function selection buttons to display the slider.

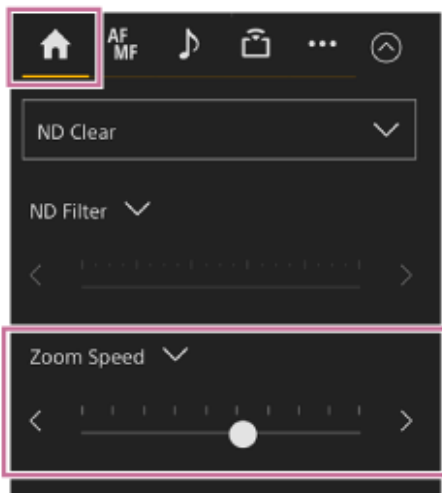

3 Move the [Zoom Speed] slider knob left or right.

Moving the knob to the left decreases the operating speed, while moving the knob to the right increases the operating speed.

TP1001804499

Color Video Camera
BRC-AM7

Adjusting the Zoom Using the Supplied Infrared Remote Control

You can adjust the zoom of the unit using optical zoom or Clear Image Zoom. This topic describes how to make adjustments using the supplied infrared remote control. For details about Clear Image Zoom, see “Setting the Zoom Type.”

1 Press the zoom button to adjust the zoom.

Press the T (Telephoto) or W (Wide) button while monitoring the screen to adjust the zoom.

To zoom in, press the T button.

To zoom out, press the W button.

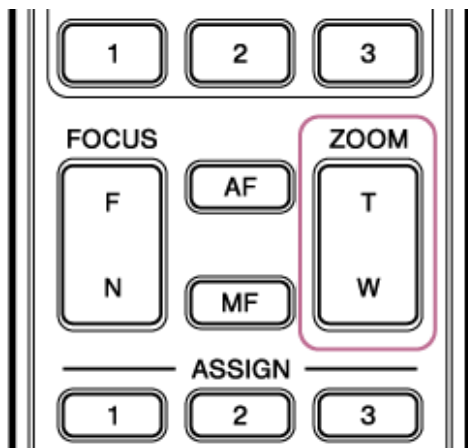

Note

- Depending on the direction of the camera and the zoom position, part of the unit or cables connected to the connector block may be visible. Before shooting, check the range that will be captured. You can also control the pan/tilt range using [Pan-Tilt] – [P/T Range Limit] in the web menu. When the unit is turned on or pan/tilt reset is executed, this range limit setting is ignored. For details, see [Pan-Tilt] – [P/T Range Limit] in the web menu.

Related Topic

- [Setting the Zoom Type](#)

TP1001804500

Color Video Camera
BRC-AM7

Saving/Restoring Pan/Tilt, Zoom Position, and Focus Setting Using the Web App

You can save the pan/tilt, zoom position, and focus setting and recall them when required using the Web App (preset position function).

- For details about the items that can be saved/restored, see “Preset Position Saved Items.”

Note

- A preset position cannot be saved if the Clear Image Zoom ratio exceeds 1×.
- If the [Pan-Tilt] – [P/T Direction] – [Ceiling] setting in the web menu is changed, all the saved preset positions are deleted.

1 Determine the position that you want to save using pan/tilt and zoom operations.

2 Press the [+] button in the preset position control panel.

The image with the saved position is displayed in the preset position control panel.

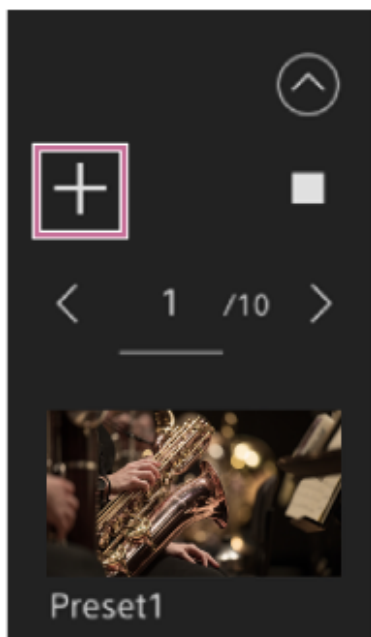

Hint

- If the preset position control panel is not displayed, press the  (Open) button to display it.
- Positions are saved in sequence from [Preset1].
- If there are unused presets within a sequence of presets, positions will be saved in presets starting with the unused presets. For example, if preset positions are saved in [Preset1] and [Preset3] but not in [Preset2], the next preset positions will be saved in [Preset2] and then in [Preset4].
- Up to 100 preset positions can be saved.
- You can rename each preset position. See “Renaming Preset Positions Using the Web App.”

3 Restore a saved position.

Double-press the position thumbnail you want to restore in the preset position control panel to restore the corresponding position.

Hint

- You can also restore a position by pressing the image, pressing the  (Preset position menu) button that appears and selecting [Recall].
- The transition speed to a saved position is determined by the [Pan-Tilt] – [P/T Preset] – [Pan-Tilt Speed] – [Common Speed] setting in the web menu when the position was saved. You can also change the transition speed after saving. For details, see “Changing the Transition Speed (Pan-Tilt/Zoom/Focus) When Restoring a Preset Position.”
- The degree of change in the pan/tilt position when moving to a preset position can be adjusted using the transition speed and [Ramp Curve] settings. For details, see “Changing the Transition Speed (Pan-Tilt/Zoom/Focus) When Restoring a Preset Position” and “Setting the Pan/Tilt Operation Acceleration.”
- If a different preset is recalled during preset playback, the operation of the first recalled preset stops and operation of the subsequently recalled preset starts.

Note

- If the temperature of the environment has changed significantly between when a preset position was saved and when it is restored, deviation in the framing may occur.
- While a preset position is being restored, you cannot perform any operations other than restoring or canceling the preset position.

To cancel the restore preset position operation

Press the  (Cancel restore) button displayed on the preset position control panel during restore preset position operation to cancel the restore operation. Use the joystick and [Zoom] slider to adjust the framing.

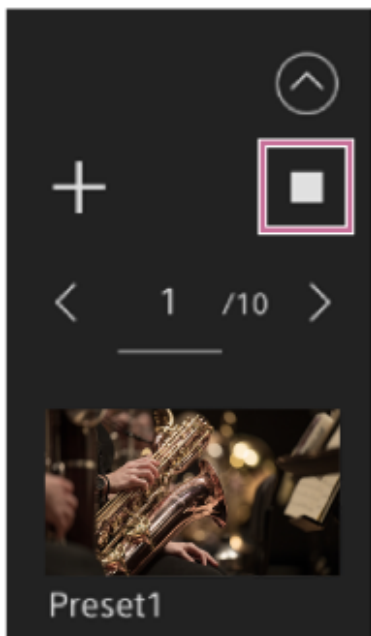

Related Topic

- [Preset Position Saved Items](#)
- [Renaming Preset Positions Using the Web App](#)
- [Changing the Transition Speed \(Pan-Tilt/Zoom/Focus\) When Restoring a Preset Position](#)
- [Setting the Pan/Tilt Operation Acceleration](#)

Color Video Camera
BRC-AM7

Renaming Preset Positions Using the Web App

You can rename saved preset positions.

1 Press the preset position you want to rename.

The  (Preset position menu) button appears at the top right of the image.

2 Press the  (Preset position menu) button and select [Rename] from the displayed menu.

3 Enter a new preset name.



TP1001804502

Color Video Camera
BRC-AM7

Replacing a Saved Preset Position with a New Position Using the Web App

You can replace a saved preset position with a new position.

- 1 Determine the position that you want to save using pan/tilt and zoom operations.**
- 2 Press the position image you want to replace in the preset position control panel.**

The  (Preset position menu) button appears at the top right of the image.
- 3 Press the  (Preset position menu) button and select [Replace] from the displayed menu.**



The new position replaces the current setting.

TP1001804503

Color Video Camera
BRC-AM7

Deleting a Saved Preset Position Using the Web App

You can delete saved preset positions.

- 1 Press the position image you want to delete in the preset position control panel.**
The  (Preset position menu) button appears at the top right of the image.
- 2 Press the  (Preset position menu) button and select [Delete] from the displayed menu.**
The saved position is deleted.

TP1001804504

Color Video Camera
BRC-AM7

Changing the Transition Speed (Pan-Tilt/Zoom/Focus) When Restoring a Preset Position

You can change the transition speed (pan/tilt operation, zoom operation, focus operation) when restoring a saved preset position.

1 Set [Pan-Tilt] – [P/T Preset] – [Pan-Tilt Speed] to [Setting Way] to [Separate] in the web menu.

2 Press the image for the preset position for which you want to change the transition speed.

The  (Preset position menu) button appears at the top right of the image.

3 Press the  (Preset position menu) button and select [Edit...] from the displayed menu.

The setup screen for the selected preset position appears.



4 Set the transition speeds (Pan-Tilt/Zoom/Focus) you want to change using the sliders or enter values directly and press the [OK] button.

The next time a saved position is restored, the camera will move at the configured speed.

Hint

- When [Pan-Tilt] – [P/T Preset] – [Pan-Tilt Speed] – [Setting Way] is set to [Common] in the web menu, all preset positions will be restored at the speed set using [Pan-Tilt] – [P/T Preset] – [Pan-Tilt Speed] – [Common Speed].
- You can also set the default value when [Pan-Tilt] – [P/T Preset] – [Pan-Tilt Speed] – [Setting Way] is set to [Separate] in the web menu.
- After zoom movement is completed, the camera moves to the saved focus position.
- After the movement is completed, [AF Transition Speed] returns to its original setting.

Color Video Camera
BRC-AM7

Saving/Restoring Pan/Tilt and Zoom Position Using the Supplied Infrared Remote Control

You can save the pan/tilt and zoom position and recall them when required using the supplied infrared remote control.

- 1 Adjust the pan/tilt and zoom of the camera.
- 2 Press and hold the PRESET button and press one of the 1 to 3 buttons.

The position is saved.

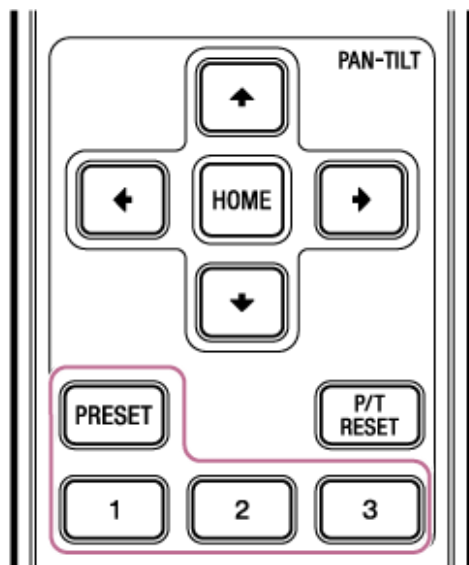

- 3 Restore a saved position.

Press one of the 1 to 3 buttons to restore that preset position.

Hint

- The transition speed when restoring a preset position is the transition speed value that was saved using [Pan-Tilt] – [P/T Preset] in the web menu. You can change the transition speed after saving a value. For details, see “Changing the Transition Speed (Pan-Tilt/Zoom/Focus) When Restoring a Preset Position.”

Related Topic

- [Changing the Transition Speed \(Pan-Tilt/Zoom/Focus\) When Restoring a Preset Position](#)

TP1001804507

Color Video Camera
BRC-AM7

About PTZ Auto Framing

The unit is equipped with a PTZ auto framing function that recognizes people and automatically adjusts the camera direction and zoom position.

PTZ auto framing has two modes: “manual tracking start mode” in which you can start tracking a person manually, and “auto tracking start mode” in which tracking of a person will start automatically when the person enters an area configured beforehand.

Set the mode to use before using this function using the procedure described in “Configuring PTZ Auto Framing Initial Settings.”

- For details about PTZ auto framing operation in manual tracking start mode, see “Specifying the Subjects for Automatic Tracking (manual tracking start mode).”
- For details about PTZ auto framing operation in auto tracking start mode, see “Selecting Subjects in a Specified Position and Tracking Automatically (auto tracking start mode).”

You can monitor the PTZ auto framing execution status using the tally lamp of the unit. For details, see “Checking the PTZ Auto Framing Status Remotely.”

Note

- During PTZ auto framing, the information displayed on the camera image is minimal.
- During auto focus, the person being tracked is the focus target. To focus on something other than the person you are tracking, set to manual focus.
- Settings related to auto focus cannot be changed during PTZ auto framing operation.
- Proper auto tracking operation may not be possible if the camera focus or exposure is not set properly, or due to factors such as the shooting environment (for example, brightness), the shooting angle (extremely high angle or low angle), or the density, size, clothing, movement, or obscuring of people.
- The full effectiveness of the face recognition function may not be obtained if the following conditions are not met.
 - Facing toward the front
 - Normal facial expression (eyes closed, no extreme facial expressions such as anger or crying)
 - No excessive covering of the face (sunglasses, mask, etc.)
- If the [Zoom Type] setting, which affects the framing, when PTZ auto framing is executed is different from the setting when PTZ auto framing was configured, auto tracking may not work properly.
- If the [Zoom Type] was changed, change the settings on the [Start Position] screen and [Detection Settings] screen of the PTZ AFR setup screen. For details, see “Configuring PTZ Auto Framing Initial Settings.”
- When using a DC IN power supply, PTZ auto framing may stop or become unusable if the input voltage is low.
- If the [P/T Range Limit] was changed, check the settings on the [Start Position] screen and [Detection Settings] screen of the PTZ AFR setup screen. For details, see “Configuring PTZ Auto Framing Initial Settings.”
- PTZ auto framing cannot be executed during thumbnail display, playback, Rec Review, and when HDMI output is not possible.

Related Topic

- [Configuring PTZ Auto Framing Initial Settings](#)
- [Specifying the Subjects for Automatic Tracking \(manual tracking start mode\)](#)
- [Selecting Subjects in a Specified Position and Tracking Automatically \(auto tracking start mode\)](#)
- [PTZ Auto Framing Using the Supplied Infrared Remote Control](#)
- [Checking the PTZ Auto Framing Status Remotely](#)

Configuring PTZ Auto Framing Initial Settings

This topic describes how to configure PTZ auto framing initial settings.

1 Press the [PTZ AFR Settings] tab.

The [Initial Setup] screen of the PTZ AFR setup screen appears.

2 Check the description on the screen and press the [Start] button.

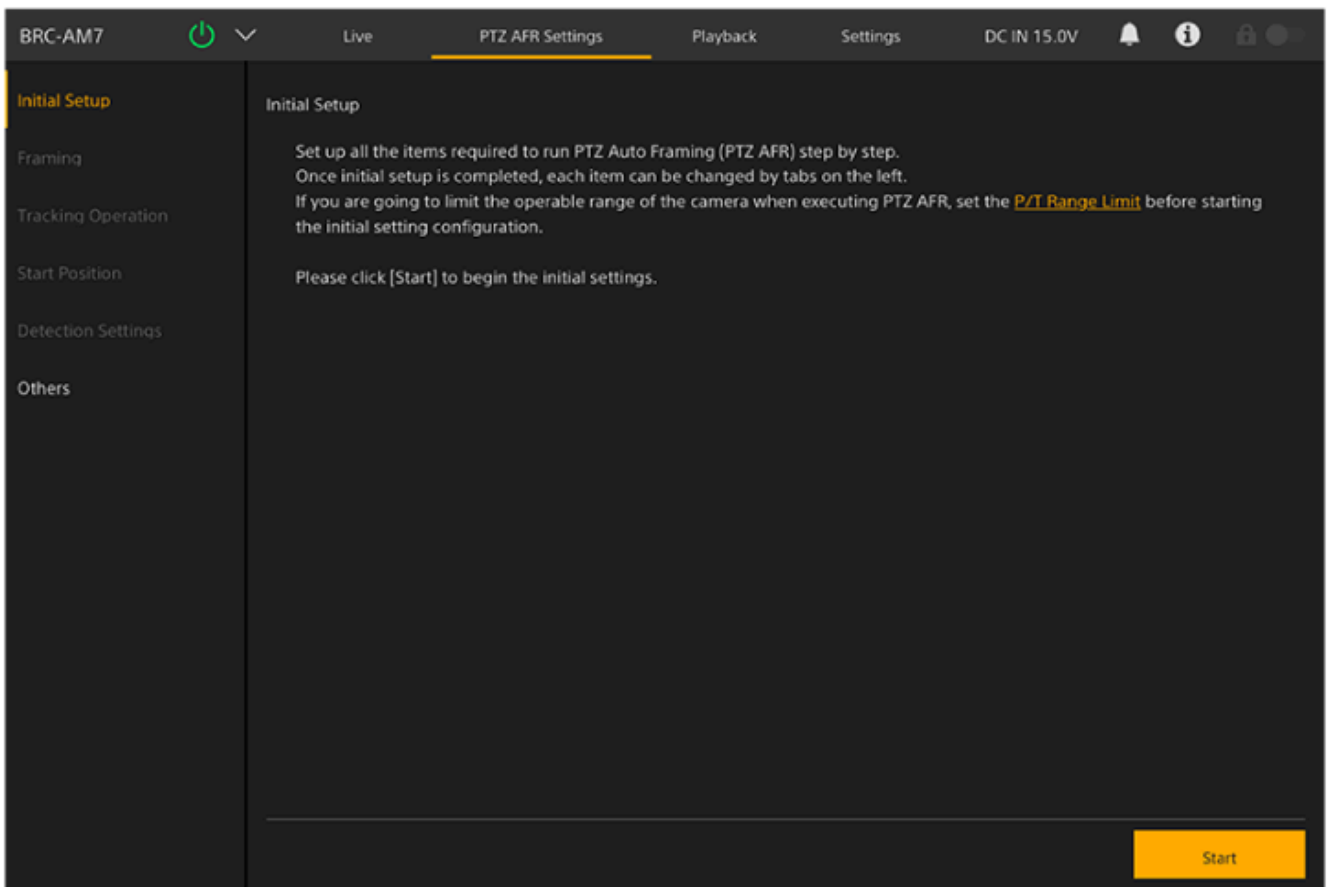

Hint

- The [Start] button is displayed only when configuring settings for the first time.

Configuration of the PTZ auto framing settings starts.

3 Adjust the desired PTZ auto framing composition on the [Framing] screen.

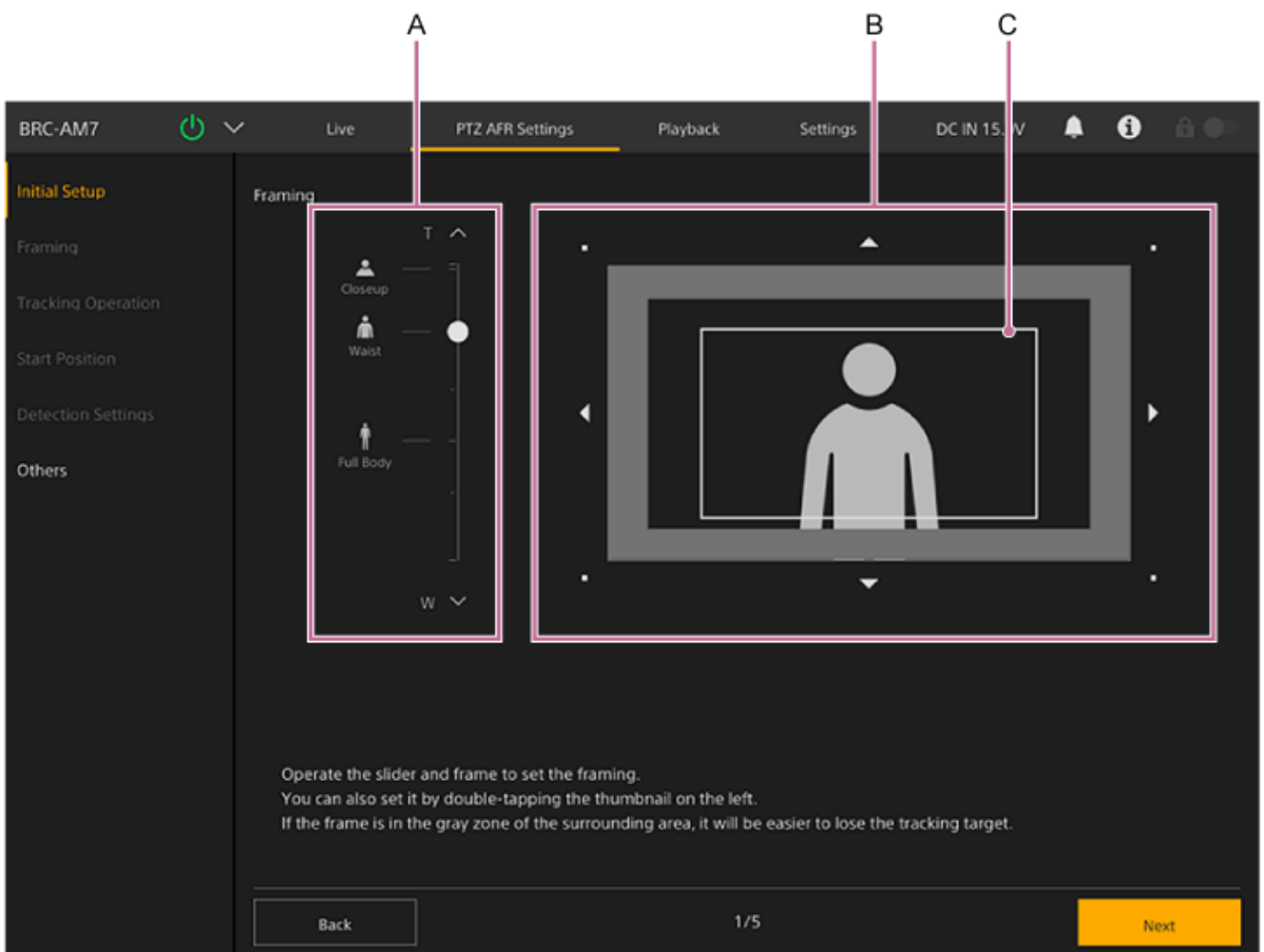

A: Human body size slider

B: Composition adjustment panel

C: Composition frame

Adjust the size and position of the person within the image.

Hint

- Double-clicking an icon on the left side of the human body size slider will set the composition frame to the size (zoom ratio) and position of the person for that icon.

Note

- If the white composition frame overlaps the gray zone, it will be easy to lose people moving in the opposite direction.
- If you compose your shot so that the person is large, it will be easy to lose people if they move quickly. In this case, make the person smaller and position them so that there is enough room to move around.

4 When finished configuring, press the [Next] button.

The next setup screen appears.

5 Set the tracking mode on the [Tracking Operation] screen.

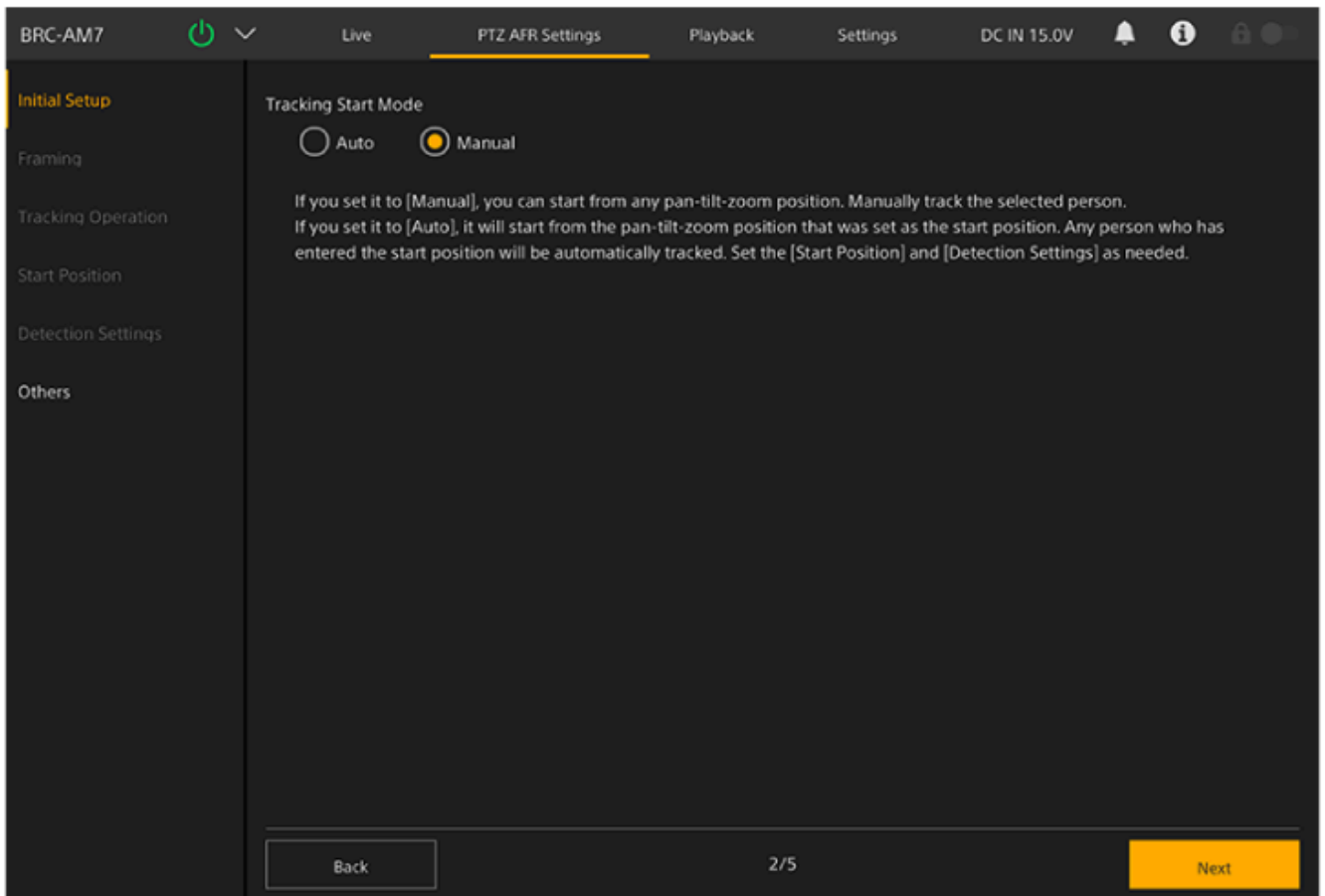

Sets the tracking start mode.

- [Auto]: In this mode, tracking a person automatically starts when a person enters the specified detection area in the field of view configured for the start position (auto tracking start mode). When this setting is selected, configuration on the [Start Position] screen and [Detection Settings] is required.
- [Manual]: In this mode, tracking does not start until you manually specify the person to track (manual tracking start mode).

6 When finished configuring, press the [Next] button.

The next setup screen appears.

- When [Auto] is selected, go to step 7.
- When [Manual] is selected, go to step 11.

7 Set the start position for auto tracking on the [Start Position] screen.

Configure the start position used when PTZ auto framing is in auto tracking start mode. This setting is not required for manual tracking start mode.

The camera will return to the start position when you press the  (Restart) button on the live operation screen or if tracking of the person you were tracking is lost.

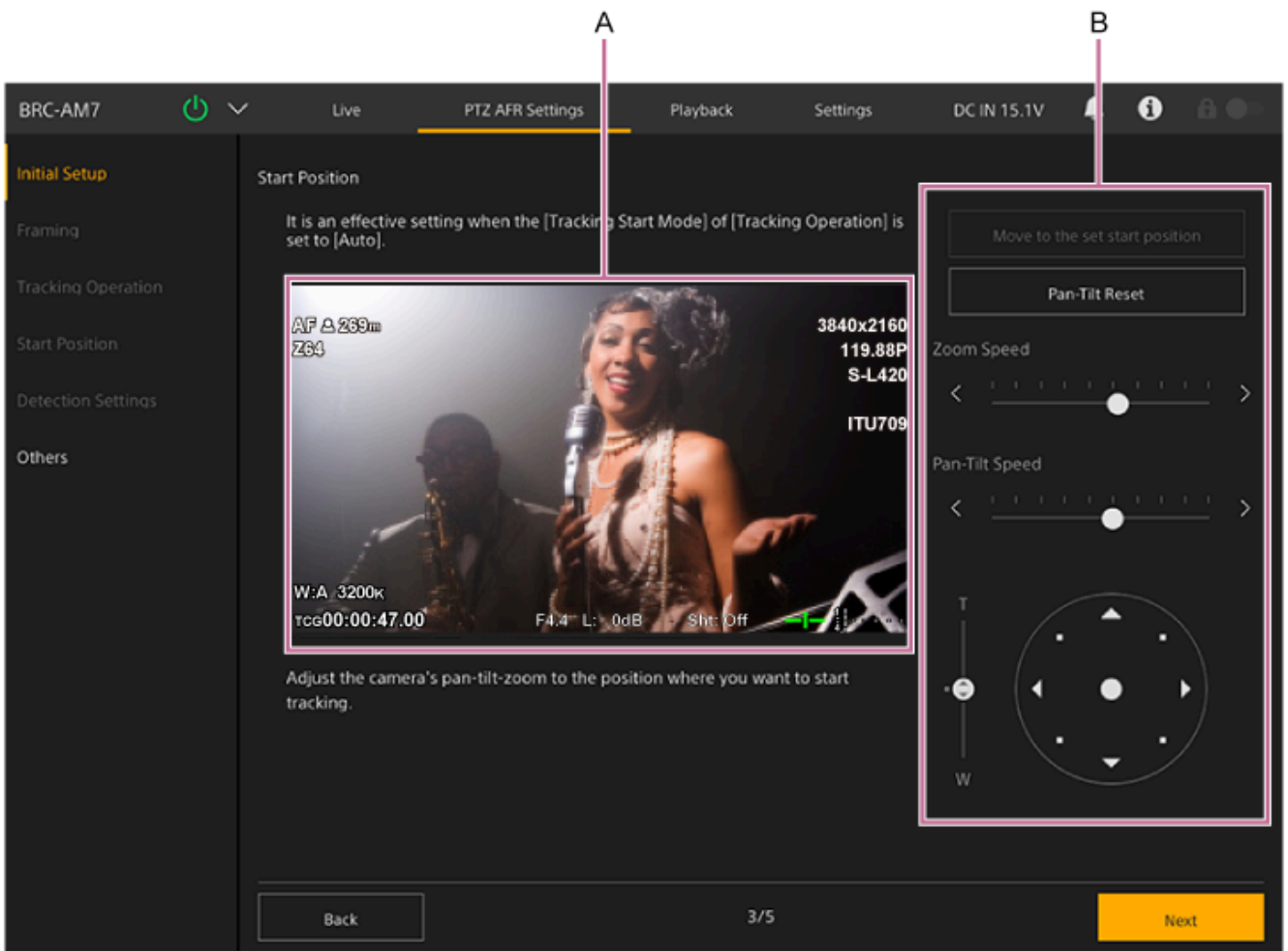

A: Camera image panel
 B: Framing control panel
 Set the start position.

- Set the start position using the framing control panel to pan, tilt and zoom the camera image while monitoring the camera image in the camera image panel. You can adjust the pan/tilt and zoom transition speed using the sliders.
- By default, the [Move to the set start position] button is disabled. It is enabled after the initial configuration is completed. Press it to move to the currently configured start position.
- Press the [Pan-Tilt Reset] button to reset the pan/tilt. Press the button when the POWER lamp and NETWORK lamp are blinking simultaneously on the front panel of the unit or when [Execute Pan-Tilt Reset.] is displayed in the framing control panel.

Note

- Reconfiguration will be required in the following cases.
 - When [Rec Format] – [Video Format] is changed from 1920×1080 to 3840×2160 during Clear Image Zoom operation
 - When the [Zoom Type] setting is changed
 - When [S&Q Motion] – [Frame Rate] is set to a value exceeding 60fps
 - When [P/T Range Limit] is changed
 - When [P/T Direction] – [Direction] – [Ceiling] is changed

8 When finished configuring, press the [Next] button.

The next setup screen appears.

9 Set the detailed settings related to auto tracking start on the [Detection Settings] screen.

This setting is not required for manual tracking start mode.

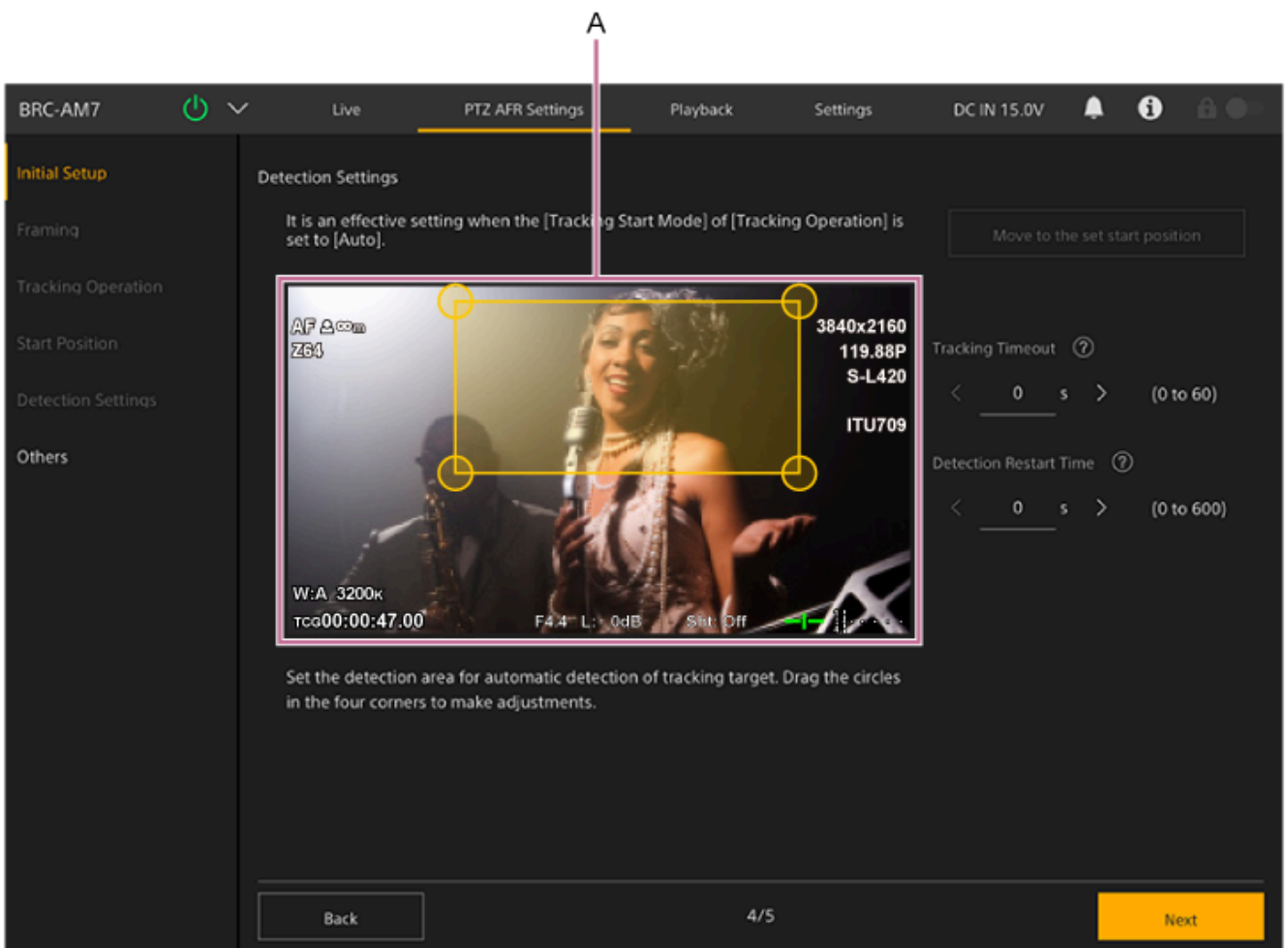

A: Detection range setup panel

Sets the range for detecting the target person to track.

- Set the tracking range by dragging the circles on the four corners of the orange frame in the detection range setup panel while monitoring the camera image. A person entering this range will become the target for auto tracking.
- By default, the [Move to the set start position] button is disabled. It is enabled after the initial configuration is completed. Press it to move to the currently configured start position.
- [Tracking Timeout]: Set the time for returning to the start position if detection of the tracking target face is lost. Set to 0 seconds to disable the timeout function (default value: 0 seconds).
- [Detection Restart Time]: Set the time between when auto tracking starts until it restarts automatically. Set to 0 seconds to disable the auto restart function (default value: 0 seconds).

Note

- Reconfiguration will be required if the start position setting is changed.

10 When finished configuring, press the [Next] button.

The next setup screen appears.

11 Configure the settings on the [Others] screen.

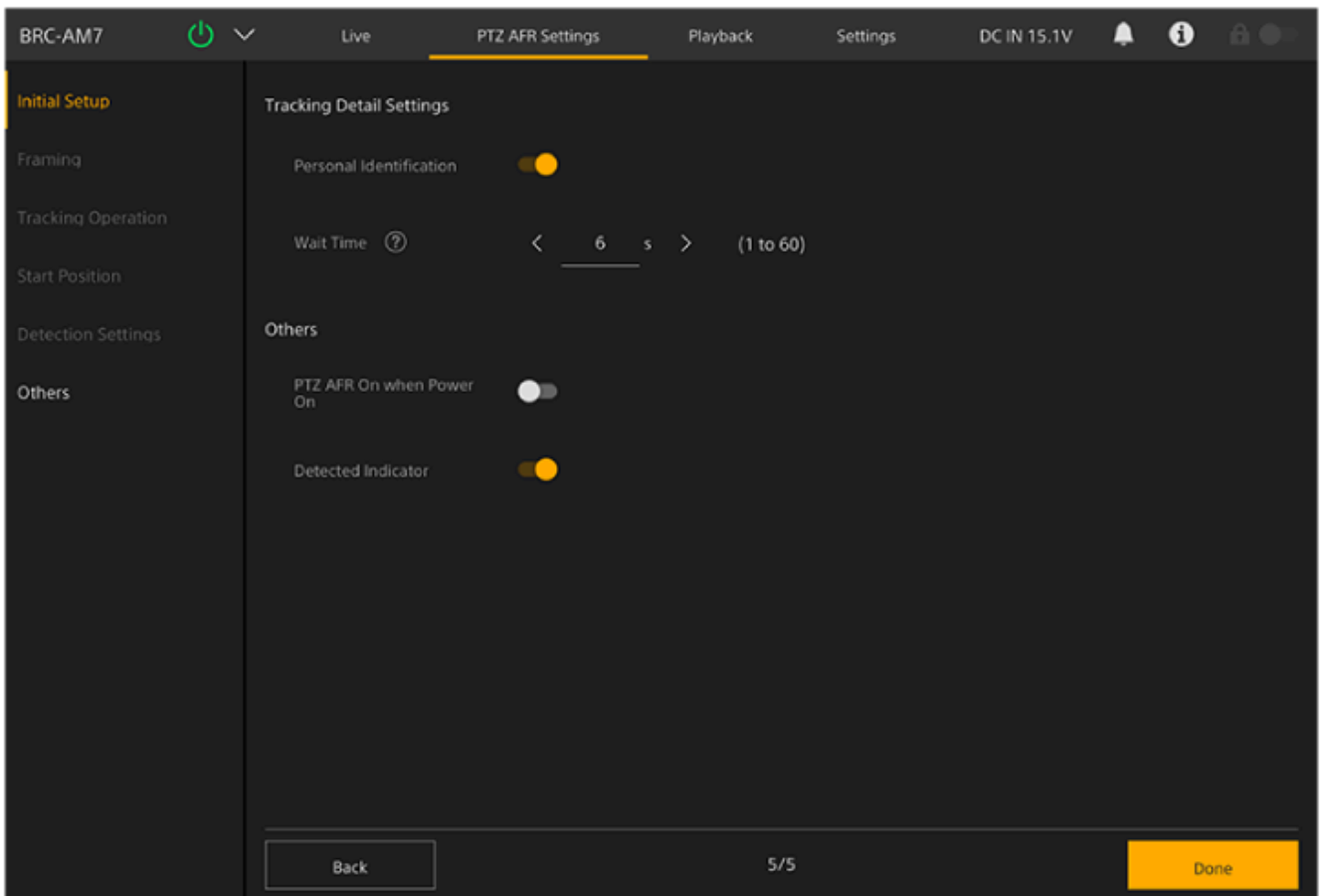

Configure the following settings, as required.

- [Personal Identification]: Set to the on position for normal operation. Set to the off position if you want the camera to automatically track someone at all times without identifying them.
- [Wait Time]: Set the time to stop pan/tilt/zoom operation and wait when the tracking target is lost.
- [PTZ AFR On when Power On]: Set to the on position to start with PTZ auto framing enabled when the unit is turned on.
- [Detected Indicator]: Set to the on position to display a frame around a detected person's face as a target or candidate for auto tracking. It also displays the detection range for the start position.

12 When finished configuring, press the [Done] button.

The following completion screen appears.

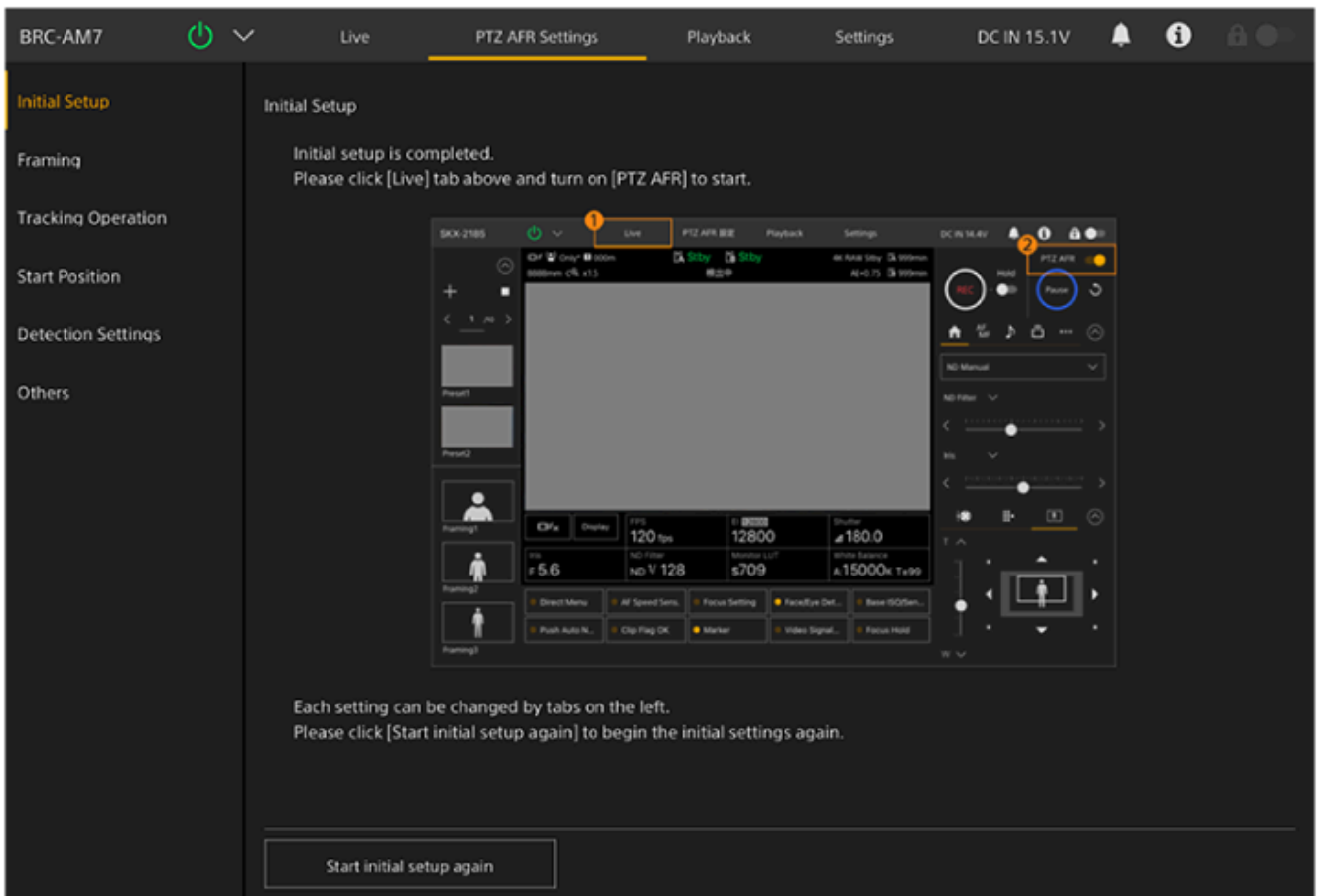

Configuration of the PTZ auto framing initial settings is completed.

Once you have completed the initial setup, you can open each page individually from the items on the left side of the PTZ AFR settings screen. If any settings are changed, press the [OK] button on each page to apply the settings.

TP1001804508

Color Video Camera
BRC-AM7

Specifying the Subjects for Automatic Tracking (manual tracking start mode)

In this mode, you manually specify the person you want to track to start tracking.

1 Check that the human tracking start mode is set to manual tracking start mode on the PTZ AFR setup screen.

For details about the tracking start mode, see “Configuring PTZ Auto Framing Initial Settings.”
If the initial settings have not been configured, the unit operates in manual tracking start mode.

2 Capture the person you want to track in the Web App framing control panel using the camera.

Hint

- You can also recall a preset position setting and use that framing to capture a person.

3 Set the [PTZ AFR] switch to the on position on the live operation screen.

The area around the [Pause] button blinks blue.

Hint

- You can also press the PTZ AUTO FRAMING ON button and OFF button of the supplied infrared remote control to set the [PTZ AFR] switch on/off.

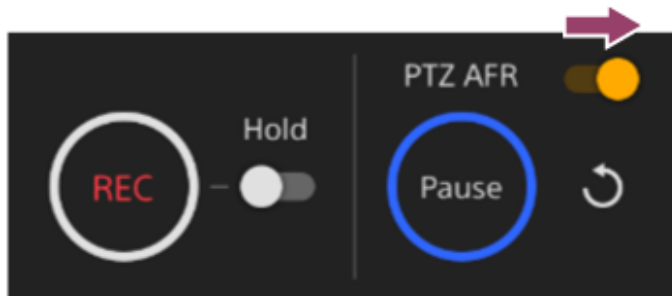

4 Tap a person to track in the camera image panel.

The area around the [Pause] button is lit blue.

During auto tracking, the [Pause] button is enabled.

You can change the person to track at any time during auto framing. Tap the person you want to track to switch the tracking target to that person.

5 Press the [Pause] button to pause pan/tilt/zoom operation due to auto tracking, as required.

The area around the [Pause] button blinks blue.

- If you press the [Pause] button during auto framing, the pan/tilt/zoom operation due to auto tracking is paused, and the button changes to a [Resume] button. To resume auto framing, press the [Resume] button.
- If you operate the joystick/zoom slider or recall a preset position during auto framing, the pan/tilt/zoom operation due to auto tracking is paused, and the button changes to a [Resume] button. To resume, press the [Resume] button.
- You can also tap a person to track to resume, instead of using the [Resume] button.

6 Press the  (AFR composition adjustment) tab on the live screen control panel to display the AFR composition adjustment panel.

7 Adjust the size of the person and composition position in the AFR composition adjustment panel.

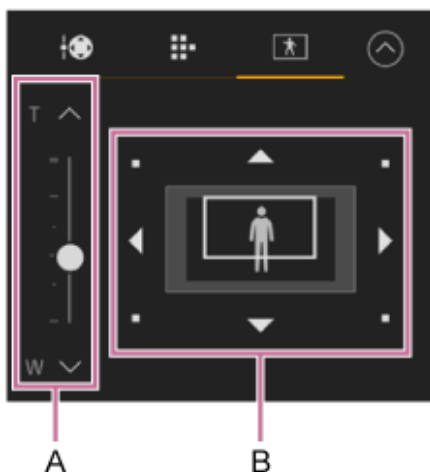

A: Human body size slider

B: Composition adjustment panel

Adjust the size and position of the person within the image.

- Set the size of the person within the image using the human body size slider.
- Set the position of the person within the image using the composition adjustment panel. Specify the composition by dragging the white composition frame.

Note

- If the white composition frame overlaps the surrounding gray zone, it will be easy to lose people moving in the opposite direction. Basically, adjust the composition frame so that the person does not enter the gray area.
- If you compose your shot so that the person is large, it will be easy to lose people if they move quickly. In this case, make the person smaller and position them so that there is enough room to move around.

Hint

- Unless you have a specific preference, setting auto focus is recommended. The tracking performance will be reduced if the person is out of focus.
- In manual tracking start mode, the  (Restart) button is disabled.

Related Topic

- [Configuring PTZ Auto Framing Initial Settings](#)

TP1001804510

Color Video Camera
BRC-AM7

Selecting Subjects in a Specified Position and Tracking Automatically (auto tracking start mode)

You can automatically track a person who appears at a specified position.

- 1 **Check that the human tracking mode is set to auto tracking start mode on the PTZ AFR setup screen and that the settings required for auto tracking have been configured.**

For details, see “Configuring PTZ Auto Framing Initial Settings.”

- 2 **Set the [PTZ AFR] switch to the on position on the live operation screen.**

The area around the [Pause] button blinks blue.

Hint

- You can also press the PTZ AUTO FRAMING ON button and OFF button of the supplied infrared remote control to set the [PTZ AFR] switch on/off.

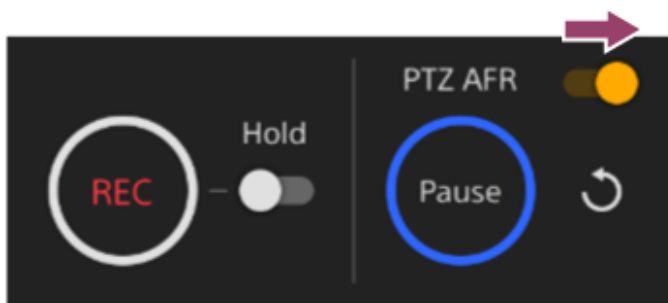

The camera image automatically moves to the start position. Auto tracking starts when a person enters the detection area.

During auto tracking, the [Pause] button is enabled and the surrounding area is lit blue.

- If detection of the person being tracked is lost, you can press the  (Restart) button to return to the start position and wait for detection of a tracking target to resume tracking. You can also manually operate the pan/tilt/zoom to bring the tracking subject into the field of view and press the [Resume] button to resume tracking.

Hint

- Unless you have a specific preference, setting auto focus is recommended. The tracking performance will be reduced if the person is out of focus.
- If you press the [Pause] button during auto framing, the pan/tilt/zoom operation due to auto tracking is paused, and the button changes to a [Resume] button. To resume auto framing, press the [Resume] button.
- If you operate the joystick/zoom slider or recall a preset position during auto framing, the pan/tilt/zoom operation due to auto tracking is paused, and the button changes to a [Resume] button. To resume, press the [Resume] button.
- During auto framing, you can adjust the composition in the AFR composition adjustment panel. For details, see “Specifying the Subjects for Automatic Tracking (manual tracking start mode).”
- If a tracking target is specified manually in auto tracking start mode, tracking of that person will take priority. To return to auto tracking start mode, press the  (Restart) button.

- If the camera completely loses sight of a person specified manually, the camera returns to auto tracking start mode.

Related Topic

- [Structure of the PTZ AFR Settings Screen](#)
- [Specifying the Subjects for Automatic Tracking \(manual tracking start mode\)](#)

TP1001804511

5-065-326-11(1) Copyright 2024 Sony Corporation

Color Video Camera
BRC-AM7



Recalling a PTZ Auto Framing Composition Preset

When PTZ auto framing is enabled, three composition presets are displayed on the live operation screen. You can change the composition instantly by recalling a composition preset instead of operating the AFR composition adjustment panel.

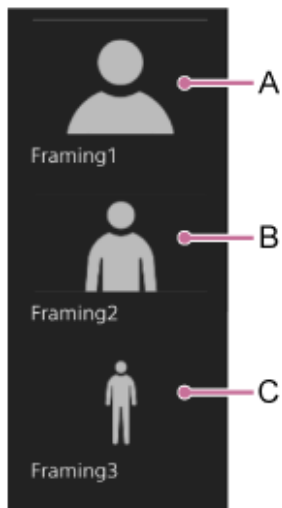
The unit is shipped with three typical composition presets.



A: Close-up size
B: Waist size
C: Full body size

- 1 Set the [PTZ AFR] switch to the on position on the live operation screen.**
The composition preset control panel is displayed on the left side of the live operation screen.
- 2 Press the composition preset to recall.**
The  (Preset Framing Menu) button appears at the top right of the image.
- 3 Press the  (Preset Framing Menu) button and select [Recall] from the displayed menu.**
The selected composition preset is recalled in the AFR composition adjustment panel.

Hint

- You can also double-tap a composition preset to recall it.

To rename a composition preset

You can rename a composition preset. For details, see “Renaming a PTZ Auto Framing Composition Preset.”

To change a composition preset

You can change a composition preset. For details, see “Switching a PTZ Auto Framing Composition Preset to a New Preset.”

Hint

- The number of composition presets is three (fixed). They cannot be added or deleted.

Related Topic

- [Renaming a PTZ Auto Framing Composition Preset](#)
- [Switching a PTZ Auto Framing Composition Preset to a New Preset](#)



TP1001868323

5-065-326-11(1) Copyright 2024 Sony Corporation

Renaming a PTZ Auto Framing Composition Preset

- 1 Set the [PTZ AFR] switch to the on position on the live operation screen.**

The composition preset control panel is displayed on the left side of the live operation screen.
- 2 Press the composition preset to rename.**

The  (Preset Framing Menu) button appears at the top right of the image.
- 3 Press the  (Preset Framing Menu) button and select [Rename] from the displayed menu.**
- 4 Enter a new composition preset name.**

TP1001868324

Switching a PTZ Auto Framing Composition Preset to a New Preset

You can replace an existing composition preset with a new composition.

1 Set the [PTZ AFR] switch to the on position on the live operation screen.

The composition preset control panel is displayed on the left side of the live operation screen.

2 Adjust the size of the person and position in the AFR composition adjustment panel.

For details about adjustment, see “Specifying the Subjects for Automatic Tracking (manual tracking start mode).”

3 Select the composition preset to replace, press the  (Preset Framing Menu) button and select [Replace] from the displayed menu.

The composition adjusted in step 2 is registered as a composition preset.

The composition preset changes to the new composition.



Replacement example

Hint

- [Framing] on the PTZ AFR settings screen and the AFR composition adjustment panel are linked. To return to the default composition, replace the composition by setting a typical composition in [Framing].

Related Topic

- [Specifying the Subjects for Automatic Tracking \(manual tracking start mode\)](#)

TP1001868325

Color Video Camera
BRC-AM7

PTZ Auto Framing Using the Supplied Infrared Remote Control

You can turn PTZ auto framing on/off using the supplied infrared remote control.

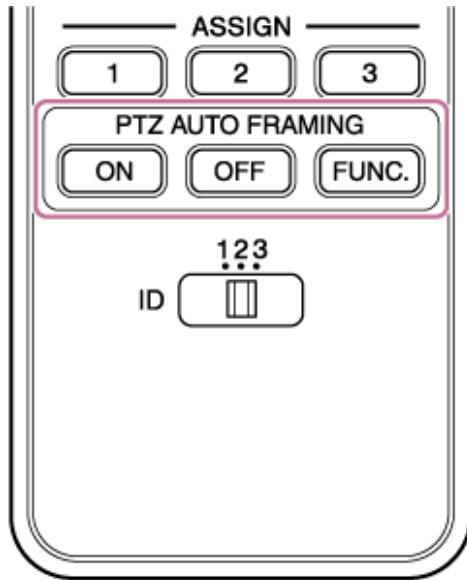

Press the ON button turn on PTZ auto framing.

Press the OFF button to turn off PTZ auto framing.

Hint

- The FUNC. button is not used on the unit.

TP1001868326

Checking the PTZ Auto Framing Status Remotely

You can monitor the PTZ auto framing status using the tally lamp of the unit.

1 Set **[Technical]** – **[Tally]** – **[Tally Control]** to **[PTZ AFR]** in the web menu.

The tally lamp changes as follows according to the PTZ auto framing status.

Tally lamp	PTZ auto framing status
Not lit	PTZ auto framing is off.
Lit blue	Auto tracking is in progress.
Blinking blue	PTZ auto framing is on, but operator intervention is required. Check the message displayed in the camera image panel of the live operation screen and take the required action.

Hint

- In auto tracking start mode, the tally lamp blinks blue until a person enters the detection area.

Related Topic

- [\[Tally\]](#)

TP1001804512

Focus Adjustment Screen

The focus is adjusted using the following parts of the live operation screen of the Web App.

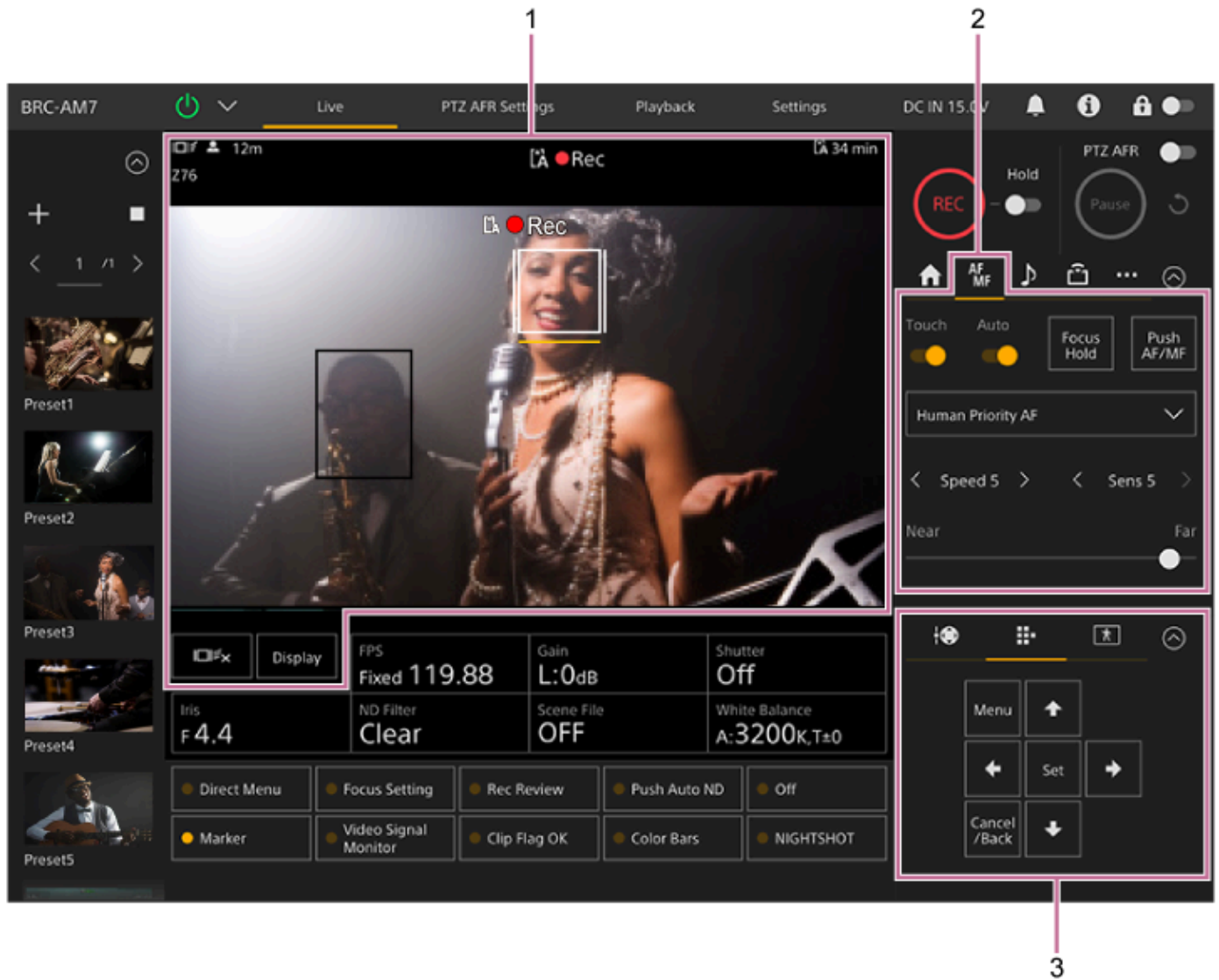

1. Camera image panel

You can adjust the focus by touching the camera image. You can disable touch operation in the Web App by setting the [Touch Focus] switch on the  (Focus) tab to the off position in the camera control panel.

2. Camera control panel – (Focus) tab

3. GUI control panel

Color Video Camera
BRC-AM7

Adjusting the Focus Manually Using the Web App

You can adjust the focus manually, for example, in the following cases.

- Subjects partially obscured by water droplets
- Subjects with low contrast against the background
- Subjects further away than nearby subjects

Note

- Manual focusing cannot be controlled from the Web App while zoom operation is in progress.

- 1 Slide the [Auto Focus] switch to the left position in the camera control panel to turn auto focus off.

Manual focus mode is activated.

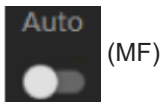

- 2 Adjust using the slider at the bottom of the  (Focus) tab.

Hint

- You can also use auto focus when manual adjustment is the main method of operation. For details, see “Setting the Auto Focus Target Manually (AF Assist) Using the Web App.”

Related Topic

- [Setting the Auto Focus Target Manually \(AF Assist\) Using the Web App](#)

TP1001804514

Color Video Camera
BRC-AM7

Adjusting the Focus Manually Using the Supplied Infrared Remote Control

You can adjust the focus manually using the supplied infrared remote control.

- 1 Press the MF button on the infrared remote control.
- 2 Adjust the focus manually using the F (Far) button and N (Near) button.

To focus on a far subject, press the F button.
To focus on a near subject, press the N button.

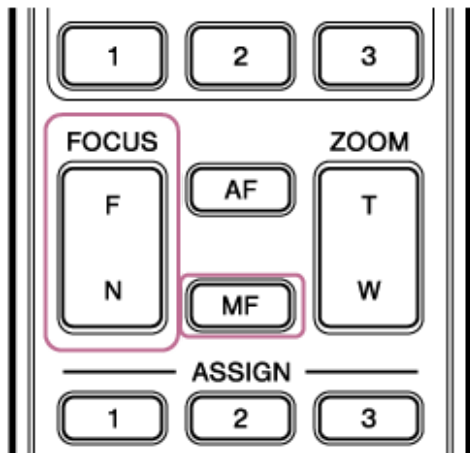

Hint

- You can also use auto focus when manual adjustment is the main method of operation. For details, see “Focusing Manually During Auto Focus Using the Supplied Infrared Remote Control.”

Related Topic

- [Focusing Manually During Auto Focus Using the Supplied Infrared Remote Control](#)

TP1001804515

Focusing by Specifying a Focus Position (Spot Focus)

In manual focus mode, you can specify the position where you want to adjust the focus in the camera image panel.

1 Set [Shooting] – [Focus] – [Touch Function in MF] to [Spot Focus] in the web menu or camera menu.

2 Slide the [Touch Focus] switch on the  (Focus) tab to the right position to turn it on.

3 Slide the [Auto Focus] switch on the  (Focus) tab to the left position to turn it off.

4 Specify the focus position.

The spot focus marker appears and the image is adjusted to be in focus at that position.

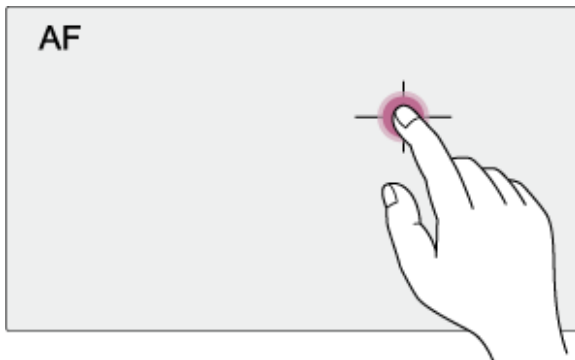

Example of specifying the position by touch operation

Hint

- In spot focus mode, you can press an assignable button assigned with [Push AF/MF] to temporarily stop spot focus and enable auto focus while the button is pressed. The focus returns to manual focus when you release the button.

Color Video Camera
BRC-AM7

Using Auto Focus Temporarily (Push Auto Focus (AF))

When in manual focus mode, you can adjust the focus temporarily using auto focus by pressing the [Push AF/MF] button to focus automatically while the button is pressed.

This is useful when you want to move the focus slowly from one subject to another subject during manual focus.

1 Slide the [Auto Focus] switch on the  (Focus) tab to the left position to turn it off.

2 Press the [Push AF/MF] button.

Auto focus is active while the button is pressed.

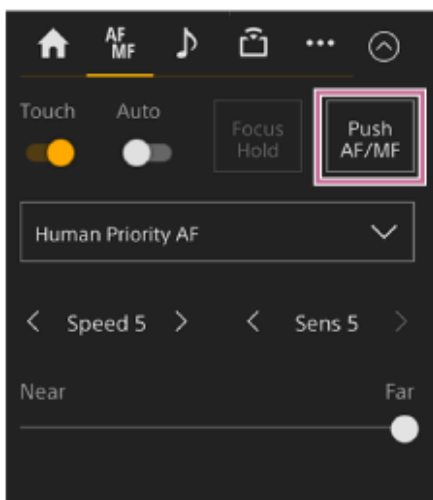

Push auto focus is released and the focus returns to manual focus when you release the button.

Hint

- The same operation is supported using an assignable button assigned with [Push AF/MF].

TP1001804517

Color Video Camera
BRC-AM7

Adjusting the Focus Automatically Using the Web App

The unit uses phase detection AF for high-speed focusing and contrast AF for high-accuracy focusing. The combination of these two AF methods provides auto focus with both high speed and high accuracy.

- 1 Slide the [Auto Focus] switch to the right position in the camera control panel to turn it on.

Auto focus mode is activated.

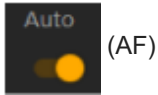

Note

- Accuracy may not be obtained depending on the shooting conditions.

Hint

- During auto focus mode, you can adjust the focus using the Focus slider in the camera control panel. For details, see "Setting the Auto Focus Target Manually (AF Assist) Using the Web App."

Related Topic

- [Setting the Auto Focus Target Manually \(AF Assist\) Using the Web App](#)

TP1001804518

Color Video Camera
BRC-AM7

Adjusting the Focus Automatically Using the Supplied Infrared Remote Control

You can adjust the focus automatically using the supplied infrared remote control.

1 Press the AF button on the infrared remote control.

The focus on a subject is adjusted automatically.

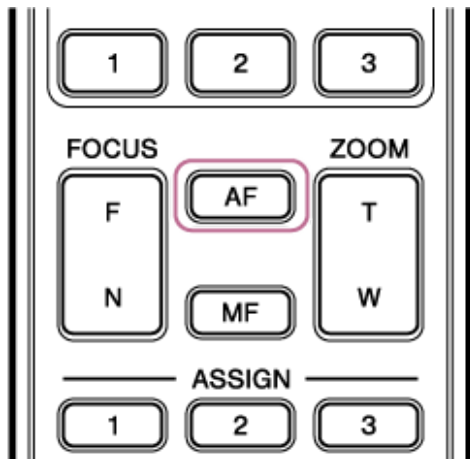

Note

- Auto focus is the basic operation, but you can make manual adjustments as an auxiliary function. For details, see “Focusing Manually During Auto Focus Using the Supplied Infrared Remote Control.”

Related Topic

- [Focusing Manually During Auto Focus Using the Supplied Infrared Remote Control](#)

TP1001804519

Color Video Camera
BRC-AM7

Setting the Auto Focus Area/Position (Focus Area)

You can set the target area for auto focus and adjust the focus for that area.

- 1 Press the [Menu] button on the GUI control panel to open the camera menu.

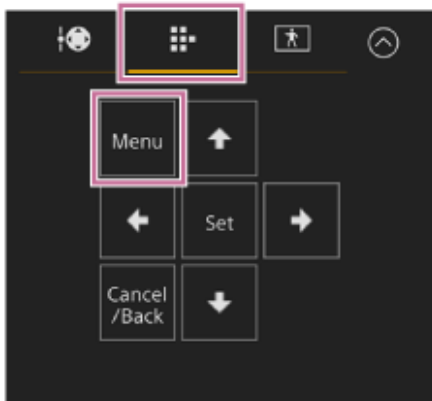

- 2 Set the target area for auto focus using [Shooting] – [Focus] – [Focus Area] in the camera menu.

[Wide]:

Searches for a subject over a wide angle of the image when focusing. A frame is not displayed.

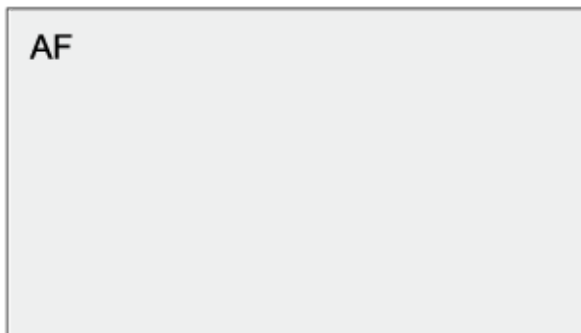

[Zone]:

Automatically searches for a focus position within the specified zone.

After selection, specify the position using the arrow buttons in the GUI control panel.

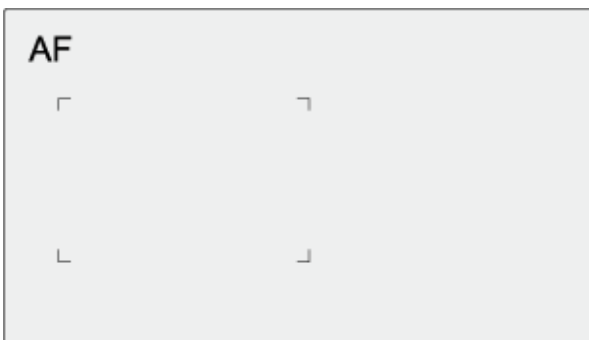

You can return to the center position by pressing and holding the [Set] button.

[Flexible Spot]:

Focuses on a specified position in the image.

After selection, specify the position using the arrow buttons in the GUI control panel.

AF



You can return to the center position by pressing and holding the [Set] button.

Note

- The focus area frame is not hidden when using the [Display] button on the camera image panel.

Hint

- You can display/hide the focus area frame indicator using [Monitoring] – [Display On/Off] – [Focus Area Indicator] in the camera menu.

TP1001804520

Color Video Camera
BRC-AM7

Changing the Focus Area Quickly (Focus Setting)

You can change the position and size of the auto focus area quickly during shooting by assigning [Focus Setting] to an assignable button.

- For details about assignable buttons, see “Assignable Buttons.”

The operation varies depending on the focus area setting.

When [Shooting] – [Focus] – [Focus Area] is set to [Flexible Spot] or [Zone] in the camera menu

- You can change the position of the focus area by pressing an assignable button assigned with [Focus Setting] and adjusting using the arrow buttons in the GUI control panel. You can return the position of the focus area to the center while adjusting the position by pressing the [Set] button.
- You can change the size of the focus area by pressing and holding an assignable button assigned with [Focus Setting]. After changing the size, you can change the position of the focus area by pressing the [Set] button. When finished, press an assignable button assigned with [Focus Setting] to return to the original screen.

When [Shooting] – [Focus] – [Focus Area] is set to [Wide] in the camera menu

You can only change the size of the focus area by pressing and holding an assignable button assigned with [Focus Setting]. The position can also be changed by first changing the type to [Flexible Spot] or [Zone].

Hint

- The focus area frame is displayed orange when the position of the focus area can be changed.

Related Topic

- [Assignable Buttons](#)

TP1001804521

Color Video Camera
BRC-AM7

Moving the Focus Area Frame Using Touch Operation (Touch Focus Area)

You can change the position of the focus area by pressing an assignable button assigned with [Focus Setting] to change the focus area display to orange, and then move the focus area frame using touch operation in the camera image panel.

Tap the screen to move the focus area, with the focus area centered on the tapped position. Drag on the screen to move the focus area to the position traced by your finger.

Hint

- You can enable/disable the touch focus area on the shooting screen using an assignable button assigned with [Focus Setting].

1 Tap any position.

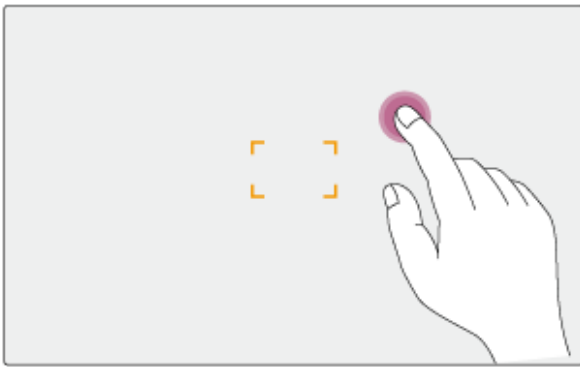

The tapped position becomes the center of the focus area.

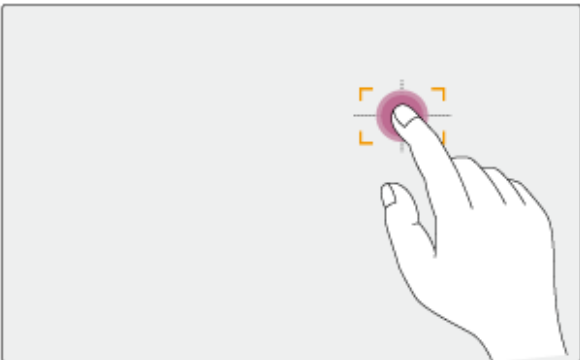

2 Drag to move the focus area, tracing your finger position.

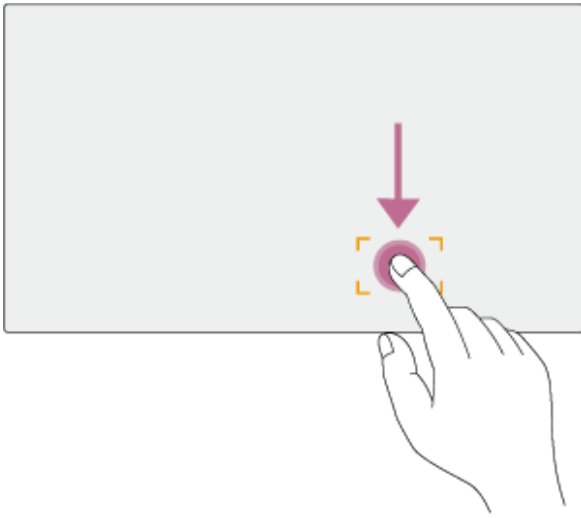

Note

- If you tap a position or drag the focus area to a position that exceeds the setting range, the focus area is set to the top/bottom/left/right edge of the setting range.
- This function is not available in the following circumstances.
 - When the [Touch Focus] switch is turned off in the camera control panel
 - When the focus area frame is displayed in gray or is not displayed at all

TP1001804522

Color Video Camera
BRC-AM7

Adjusting the Auto Focus Operation (AF Transition Speed, AF Subject Shift Sensitivity)

You can adjust the auto focus operation by changing the transition speed and the subject shift sensitivity.

Setting the AF transition speed

You can set the speed of the focus drive for when the subject changes using the [AF Transition Speed] button in the camera control panel.

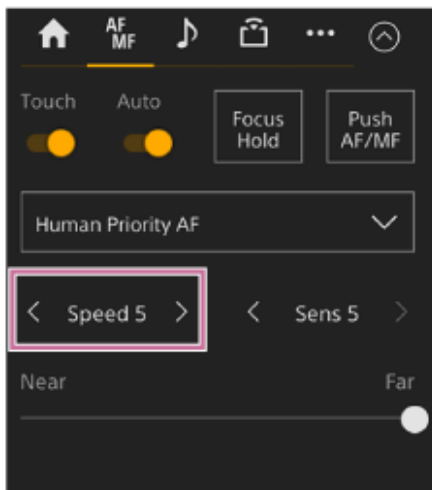

Select the speed from the range [Speed 1] (Slow) to [Speed 7] (Fast) in increments of 1. Press the < button to decrease the value (slower) or the > button to increase the value (faster).

When set to low speed, the focus moves slowly when the subject to be focused changes, enabling the shooting with impressive image expression.

When set to high speed, the focus switches between subjects quickly. In the example below, the focus changes quickly from the building in the background to the person walking in the foreground. The subject that enters the frame is immediately focused, making this setting ideal for documentary shooting which requires quick focusing.

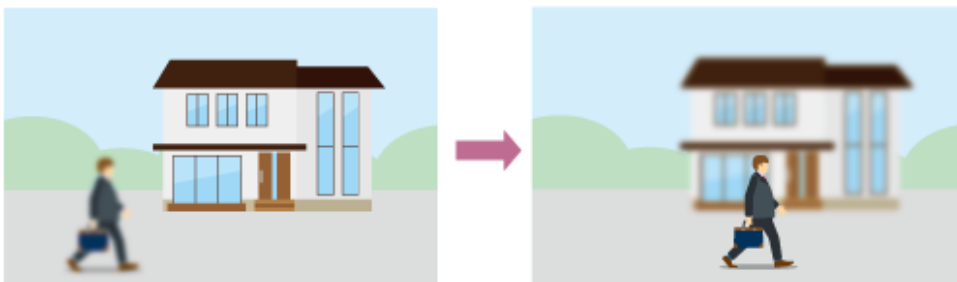

AF subject shift sensitivity

You can set the sensitivity for changing between subjects using [AF Subj. Shift Sens.] button in the camera control panel.

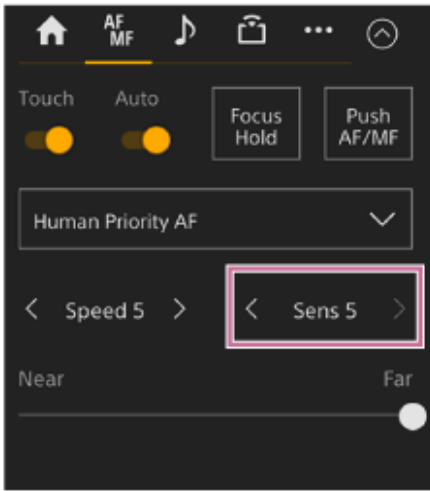

Select the sensitivity from the range [Sens 1] (Locked On) to [Sens 5] (Responsive) in increments of 1. Press the < button to decrease the value (change slowly) or the > button to increase the value (change rapidly).
 When set to a low sensitivity, the focus does not readily shift even if another subject moves in front of the in-focus subject.



When set to a high sensitivity, the focus shifts to give priority to the subject that moves in front.



Hint

- If [AF Speed/Sens.] is assigned to an assignable button, the level bars for adjusting values are displayed in the camera image panel in the following order each time the button is pressed, allowing you to change the AF transition speed and AF subject shift sensitivity settings.
 AF transition speed → AF subject shift sensitivity → No display ...

Color Video Camera
BRC-AM7

Setting the Auto Focus Target Manually (AF Assist) Using the Web App

After shifting and adjusting the focus manually, you can pass focus control to auto focus for fine focus adjustment.

- 1 Set [Shooting] – [Focus] – [AF Assist] to [On] in the camera menu.
- 2 Set [Shooting] – [Focus] – [AF Assist Control] to [On] in the web menu.
- 3 Slide the [Auto Focus] switch to the right position in the camera control panel to turn it on.
Auto focus mode is activated.
- 4 Set the focus target using the [Focus] slider in the camera control panel.

[Near]: Focus on a near subject.

[Far]: Focus on a far subject.

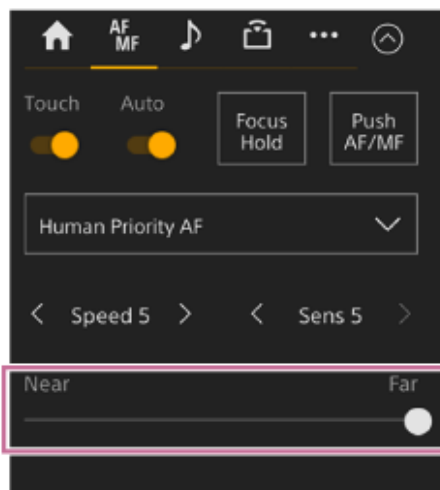

In the AF assist state, a subject at the distance set with the [Focus] slider will be focused automatically.

Note

- In the AF assist state, shifting the focus becomes difficult, regardless of the [Shooting] – [Focus] – [AF Subj. Shift Sens.] setting in the camera menu.
- The AF assist state is canceled by the following.
 - When the subject focused using the [Focus] slider is no longer visible
 - When switching to manual focus
 - When realtime tracking AF is started

Hint

- The AF assist state can be canceled quickly by using an assignable button assigned with [Push AF/MF].
- Realtime tracking AF stops when the [Focus] slider is operated.
- In human only AF mode, auto focus focuses on the face closest to the position of the [Focus] slider.

Color Video Camera
BRC-AM7

Focusing Manually During Auto Focus Using the Supplied Infrared Remote Control

When [Shooting] – [Focus] – [AF Assist] is set to [On] in the camera menu, you can use the F (Far) button and N (Near) button on the supplied infrared remote control even during auto focus to adjust the focus on a subject.

TP1001804525

Color Video Camera
BRC-AM7

Using Manual Focus Temporarily During Auto Focus (Push Manual Focus)

Press the [Push AF/MF] button when in auto focus mode to focus manually while the button is pressed. The focus returns to auto focus when you release the button.

This allows you to temporarily stop auto focus and focus manually when something that is not the subject of shooting crosses in front of the subject.

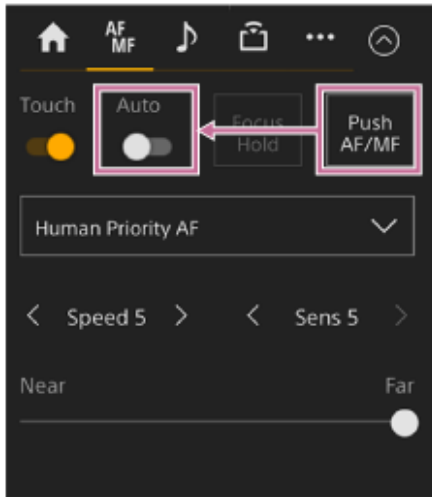

Hint

- The same operation is supported using an assignable button assigned with [Push AF/MF].

TP1001804526

Color Video Camera
BRC-AM7

Detecting and AF Tracking a Person

The unit can detect people as a target to track, and then adjust the focus on faces, eyes, head, or body within the focus area. This function is available only when the focus mode is auto focus mode or during push auto focus.

When a person is detected, a gray subject recognition frame is displayed. When auto focusing is possible, the frames change to white and tracking starts.

If a more pinpoint recognition area (such as the eyes) is recognized, that area will automatically be given priority and a recognition frame is displayed.

When multiple individuals are detected, the main subject is automatically determined.

This function is available only when the focus mode is AF mode or during push auto focus.

Hint

- When the focus area is set to [Zone] or [Flexible Spot] and individuals overlap within the specified focus area, subject recognition frames are displayed on the recognized areas (face/eye/head/body).

Setting using the [Subject Recognition AF] button in the camera control panel

Press the [Subject Recognition AF] button and set subject recognition AF operation.

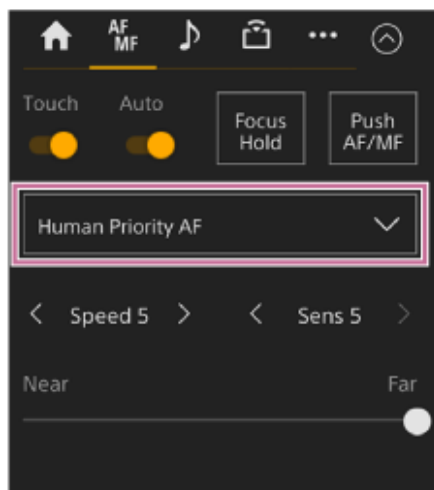

[Human Only AF]: The camera detects subjects (people) and focuses on and tracks their faces, eyes, heads, or bodies. While a face/eye/body/head is not detected, AF is temporarily stopped and the human only AF  (auto focus paused) icon is displayed. This mode is effective when you want to focus and track people only.

[Human Priority AF]: The camera detects the face/eye/head/body of subjects (people) and prioritizes the focusing/tracking on the face/eye/head/body. When a face/eye/head/body is not detected, focusing is in AF mode (default setting).

[AF]: The subject recognition AF function is disabled.

Note

- During push auto focus operation, [Human Priority AF] is activated even if [Human Only AF] is currently selected.
- When the [Auto Focus] switch is turned off, subject recognition AF operation is not available (excluding during push auto focus operation and realtime tracking AF operation).
- If you turn the unit off while [Human Only AF] is selected, the mode automatically switches to [Human Priority AF] when the unit is next turned on.

Hint

- You can set the subject recognition AF operation using [Shooting] – [Focus] – [Subject Recognition AF] in the camera menu.

To remove subject recognition frames

You can show/hide the subject recognition frames using [Monitoring] – [Display On/Off] – [Subject Recognition Frame] in the camera menu.

To switch subject recognition AF operation using an assignable button

Assign [Subject Recognition AF] to an assignable button. You can then switch subject recognition AF operation between [Human Priority AF], [Human Only AF], and [AF] each time you press the button.

Setting using the direct menu

You can also set the subject recognition AF operation using the direct menu.

- For details about the direct menu, see “Direct Menu Operation.”

Related Topic

- [Direct Menu Operation](#)

TP1001804527

Color Video Camera
BRC-AM7

AF Tracking a Specified Subject (Realtime Tracking AF)

You can maintain focus on a subject by specifying the subject by touch operation or by selecting a subject recognition frame on the camera image panel.

When a subject is selected, a white tracking frame is displayed and tracking starts.

Hint

- Tracking occurs over the entire image area, regardless of the focus area setting.
- When [Shooting] – [Focus] – [Touch Function in MF] is set to [Tracking AF] in the web menu or camera menu, realtime tracking AF is supported even when the focus mode is MF mode.

The following actions occur for the tracking target, depending on the subject recognition AF operating mode.

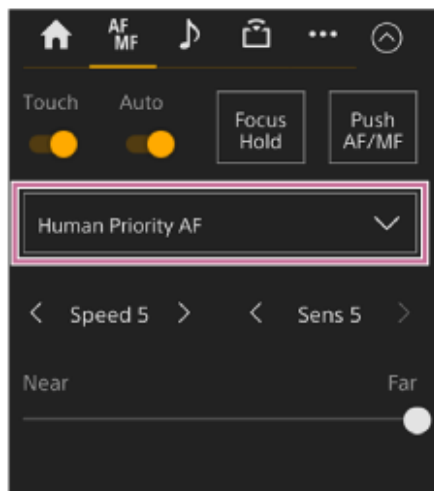

[Human Only AF] or [Human Priority AF]: Focusing and tracking of the specified subject.

If the tracking target is a person and a face/eye/head/body is detected, the camera focuses on that face/eye/head/body.

When a tracking target face/eye/head/body is detected, the tracking target face is saved. When saved, the  (saved tracking face) icon is displayed.

Note

- If tracking AF is started during manual focus, the tracking target face is not saved.

[AF]: Use for focusing and tracking of a specified subject. Face/eye/head/body detection does not occur, even if the tracking target is a person.

Starting realtime tracking AF

When a specific subject is specified as the tracking target, tracking of that target starts.

Specifying by touch operation

Slide [Touch Focus] switch on the  (Focus) tab in the camera control panel to the right position to turn it on, then tap the target subject to track in any of the following states.

- During manual focus or during push manual focus, and when [Shooting] – [Focus] – [Touch Function in MF] is set to [Tracking AF] in the web menu or camera menu
- During auto focus or during push auto focus (AF)

Specifying using the arrow buttons in the GUI control panel

When [Shooting] – [Focus] – [Multi Selector Function] is set to [Pointer] in the camera menu, you can quickly select a subject on the screen using the arrow buttons in the GUI control panel instead of touch operation.

Move the tracking AF pointer to the target subject to track using the arrow buttons, and press the [Set] button in the GUI control panel.

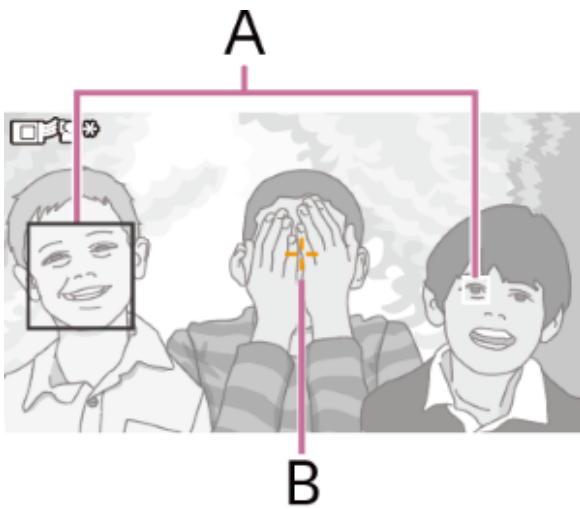

A: Eye/face detection frame

B: Tracking AF pointer

You can select a subject even when screen operation is locked.

You can change the color and edge of the tracking AF pointer to make it easier to see or to prevent the pointer from interfering with shooting.

Specifying by subject recognition frame selection

When [Shooting] – [Focus] – [Multi Selector Function] is set to [Subject Sel. Cursor] in the camera menu, you can select a subject recognition frame using the arrow buttons in the GUI control panel.

Move the subject selection cursor (orange underline) to the target subject to track using the arrow buttons, and press the [Set] button in the GUI control panel.

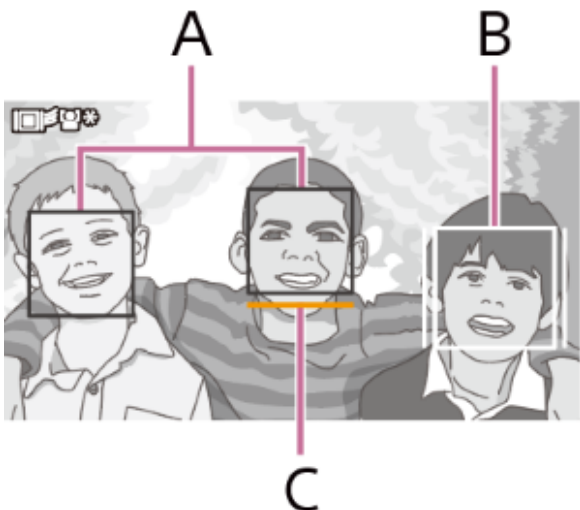

A: Face detection frames (gray)

B: Tracking frame

C: Face selection cursor (orange)

Hint

- You can also change the target to track during realtime tracking AF.

Note

- During manual focus, tracking cannot be started using subject recognition frame selection.

Stopping realtime tracking AF

Press the  (realtime tracking AF stop) button.



Hint

- Realtime tracking AF will stop in the following cases:
 - When the [Auto Focus] switch is turned on/off
 - When the focus mode is changed
 - When AF assist is executed
 - When the focus area setting or face/eye detection AF action is changed
 - When an assignable button assigned with [Push AF/MF] is pressed
 - When the tracking target is not within the shooting screen or when the subject is out of focus for a few seconds
- When a tracking face is saved (when the  (saved tracking face icon) is displayed), realtime tracking AF will resume when the saved tracking face enters the image area. To clear the tracking face, stop realtime tracking AF as described above.

TP1001804528

Brightness Adjustment Screen

You can adjust the brightness by adjusting the iris, gain, shutter speed, and by adjusting the light level using ND filters in the following control panels of the Web App live operation screen. You can also adjust the brightness automatically.



1. Camera control panel – (Main) tab

2. Camera basic configuration panel

Displays the setting status of basic functions required for shooting on buttons. Press a button to display the corresponding setup screen for each function in the camera basic configuration adjustment panel below.

3. Camera basic configuration adjustment panel

Displays the adjustment panel for the setup item selected on the camera basic configuration panel.

Color Video Camera
BRC-AM7

Setting the Target Level for Automatic Brightness Adjustment

The target level for automatic brightness adjustment is set using the [AE Level] slider in the camera control panel.

1 Press the (Main) tab in the camera control panel.

If the [AE Level] slider is not displayed, select either of the two slider function selection buttons and select the [AE Level] slider from the list.

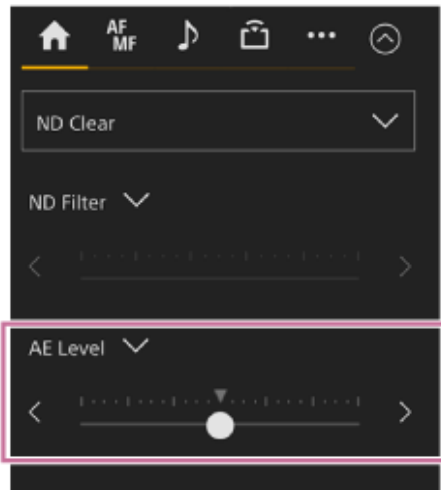

The [AE Level] slider appears.

2 Set the target level using the slider.

Move the slider knob to the left to make the image darker. Move the slider knob to the right to make the image brighter.

Hint

- Can also be set using [Shooting] – [Auto Exposure] – [Level] in the camera menu.

TP1001804530

Color Video Camera
BRC-AM7

Adjusting the Iris Automatically

You can adjust the brightness automatically according to the subject.

1 Press the [Iris] button in the camera basic configuration panel.

The frame of the [Iris] button changes to orange.



The Iris adjustment panel appears.

2 Slide the [Auto] switch to the right position to turn it on.

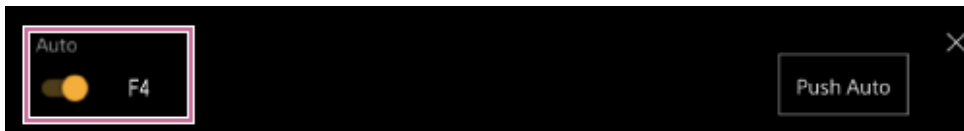

The iris switches to auto adjustment mode. The auto adjusted iris value is displayed on the right side of the switch.

Hint

- You can also assign [Auto Iris] to an assignable button.

TP1001804531

Adjusting the Iris Manually

You can adjust the brightness manually.

- 1 Press the [Iris] button in the camera basic configuration panel.

The frame of the [Iris] button changes to orange.



The Iris adjustment panel appears.

- 2 Slide the [Auto] switch to the left position to turn it off.

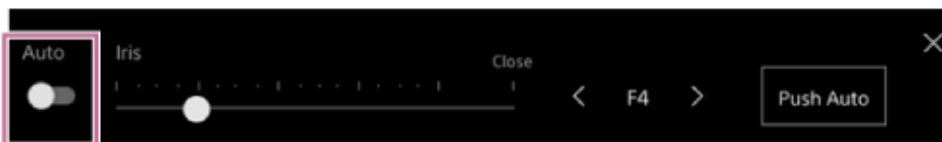

The iris switches to manual adjustment mode.

- 3 Adjust the iris using the [Iris] slider or [Iris] adjustment buttons.



Hint

- The slider and adjustment button settings are linked.
- You can also assign the iris to the slider on the  (Main) tab in the camera control panel.

To temporarily adjust the iris automatically

You can also press the [Push Auto] button on the Iris adjustment panel to adjust the iris automatically while the button is pressed.



Hint

- Press an assignable button assigned with the [Push Auto Iris] function to adjust the iris automatically while the button is pressed.

The iris returns to manual mode when you release the button.

TP1001804532

5-065-326-11(1) Copyright 2024 Sony Corporation

Color Video Camera
BRC-AM7

Adjusting the Gain Automatically

You can adjust the brightness automatically using the gain.

- 1 Press the [ISO/Gain] button in the camera basic configuration panel.

The frame of the [ISO/Gain] button changes to orange.

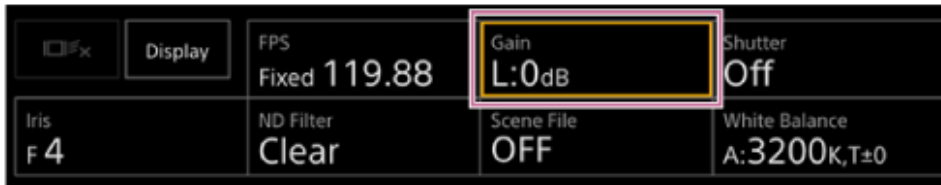

The ISO/Gain adjustment panel appears.

- 2 Slide the [AGC] switch to the right position to turn it on.



The gain switches to auto adjustment mode. The auto adjusted gain value is displayed on the right side of the switch.

Hint

- You can also perform the same action by setting [Shooting] – [Auto Exposure] – [AGC] to [On] in the camera menu.
- You can also assign [AGC] to an assignable button.

TP1001804533

Adjusting the Gain Manually

You can adjust the brightness manually using the gain.

You can control the gain when you want to adjust the exposure while using a fixed iris setting or when you want to prevent the gain increasing due to AGC.

1 Press the [ISO/Gain] button in the camera basic configuration panel.

The frame of the [ISO/Gain] button changes to orange.

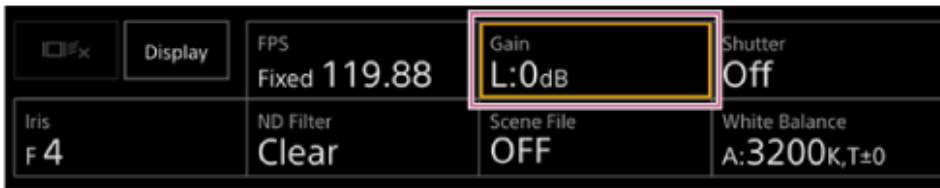

The ISO/Gain adjustment panel appears.

2 Slide the [AGC] switch to the left position to turn it off.



The gain switches to manual adjustment mode.

3 Adjust the gain using the [ISO/Gain] slider or [ISO/Gain] adjustment buttons.



Hint

- The slider and adjustment button settings are linked.

To temporarily adjust the gain manually

You can also adjust the gain temporarily by assigning [ISO/Gain] to a slider function selection button on the (Main) tab in the camera control panel and using the slider.

This is useful when you want to adjust the exposure by one step without changing the depth of field.

The adjustment result returns to the preset value configured using [ISO/Gain<L>] after performing any of the following operations.

- Changing ISO/Gain adjustment items
- Setting the AGC switch to the on position
- Switching the power supply of the unit to standby

To temporarily adjust the gain automatically using an assignable button

Press an assignable button assigned with the [Push AGC] function to adjust the gain automatically while the button is pressed.

The gain returns to manual mode when you release the button.

The adjustment result returns to the preset value configured using [ISO/Gain<L>] after performing any of the following operations.

- Changing ISO/Gain adjustment items
- Setting the AGC switch to the on position
- Switching the power supply of the unit to standby

TP1001804534

5-065-326-11(1) Copyright 2024 Sony Corporation

Color Video Camera
BRC-AM7

Adjusting the Shutter Automatically

You can adjust the shutter automatically in response to the brightness of the image.

1 Press the [Shutter] button in the camera basic configuration panel.

The frame of the [Shutter] button changes to orange.



The Shutter adjustment panel appears.

2 Press the [Shutter Type] button and select [Auto] from the list.

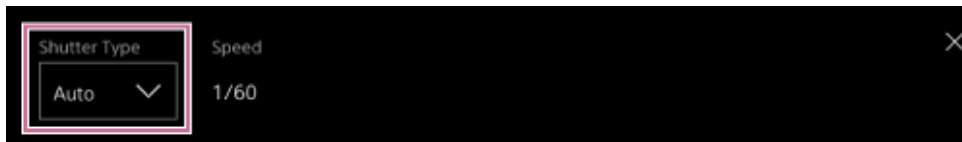

Hint

- You can also perform the same action by setting [Shooting] – [Auto Exposure] – [Auto Shutter] to [On] in the camera menu.
- You can also assign [Auto Shutter] to an assignable button.

TP1001804535

Adjusting the Shutter Manually

You can adjust the shutter manually.

- 1 Press the [Shutter] button in the camera basic configuration panel.

The frame of the [Shutter] button changes to orange.



The Shutter adjustment panel appears.

- 2 Press the [Shutter Type] button and select [Speed] from the list.



- 3 Adjust the shutter using the [Speed] slider or [Speed] adjustment buttons.



To adjust the exposure time to match the frame interval, select [Off] in step 2. You can also set a fixed value using [ECS] (frequency) or automatically adjust it using [Auto].

Example: Set using [ECS] (frequency)



Hint

- The slider and adjustment button settings are linked.
- To use [Angle] instead of [Speed] or [Off], set [Shooting] – [Shutter] – [Mode] to [Angle] in the camera menu.

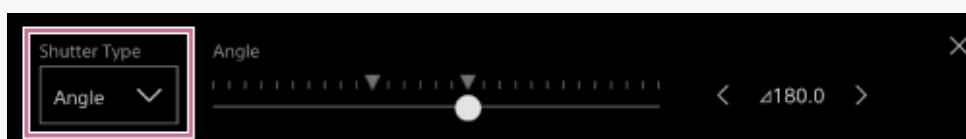

Color Video Camera
BRC-AM7

About the ND Filter

In conditions where the lighting is too bright, you can set the appropriate brightness by changing the ND filter. When shooting a brightly lit subject, closing the iris too much may cause diffraction blur, producing an image starting to go out of focus (typical phenomena in cameras). You can suppress this effect to obtain better shooting results using the ND filter. The unit features the following ND filter modes.

Preset mode

- See “Adjusting in Preset Mode.”

Variable mode (automatic adjustment)

- See “Adjusting Automatically in Variable Mode.”

Variable mode (manual adjustment)

- See “Adjusting Manually in Variable Mode.”

Related Topic

- [Adjusting in Preset Mode](#)
- [Adjusting Automatically in Variable Mode](#)
- [Adjusting Manually in Variable Mode](#)

TP1001804537

Color Video Camera
BRC-AM7

Adjusting in Preset Mode

You can select three ND filter transmittance values beforehand and quickly switch between them when shooting.

1 Set [Shooting] – [ND Filter] – [Mode] to [Preset] in the camera menu.

2 Press the [ND Filter] button in the camera basic configuration panel.

The frame of the [ND Filter] button changes to orange.

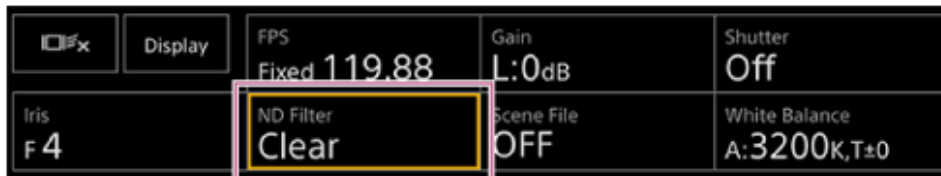

The ND Filter adjustment panel appears.

3 Press the [ND Filter] button and select one of the following from the list.

[Clear]: No ND filter.

[Preset1]: Transmittance set by [Shooting] – [ND Filter] – [Preset1] in the camera menu.

[Preset2]: Transmittance set by [Shooting] – [ND Filter] – [Preset2] in the camera menu.

[Preset3]: Transmittance set by [Shooting] – [ND Filter] – [Preset3] in the camera menu.

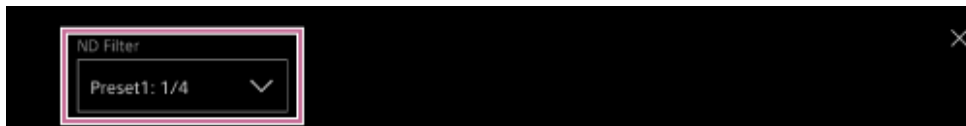

When one of [Preset1] to [Preset3] is selected for the ND filter, the transmittance value is displayed beside the ND filter name.

Hint

- When an assignable button assigned with [ND Filter Position] is pressed, the ND filter changes in the sequence [Clear] → [Preset1] → [Preset2] → [Preset3] → [Clear].

TP1001804538

Color Video Camera
BRC-AM7

Adjusting Automatically in Variable Mode

You can enable auto exposure adjustment using the ND filter.

1 Set [Shooting] – [ND Filter] – [Mode] to [Variable] in the camera menu.

2 Press the [ND Filter] button in the camera basic configuration panel.

The frame of the [ND Filter] button changes to orange.

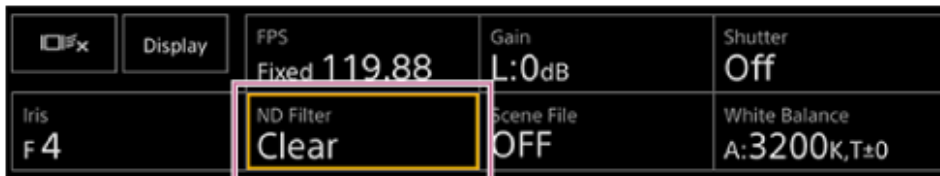

The ND Filter adjustment panel appears.

3 Press the [ND Filter] button and select [Auto] from the list.

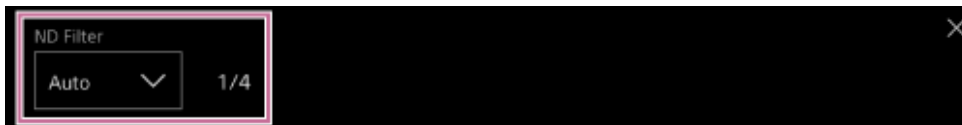

The automatically adjusted ND filter transmittance value is displayed beside the [ND Filter] button.

Note

- When the ND filter is switched to or from [Clear] during shooting, the ND filter frame is displayed on the image and an operating sound is emitted.

Hint

- You can also assign [Auto ND Filter] to an assignable button, and press the button to switch between [Auto] and [Manual].

TP1001804539

Color Video Camera
BRC-AM7

Adjusting Manually in Variable Mode

You can perform manual exposure adjustment using the ND filter.

1 Set [Shooting] – [ND Filter] – [Mode] to [Variable] in the camera menu.

2 Press the [ND Filter] button in the camera basic configuration panel.

The frame of the [ND Filter] button changes to orange.

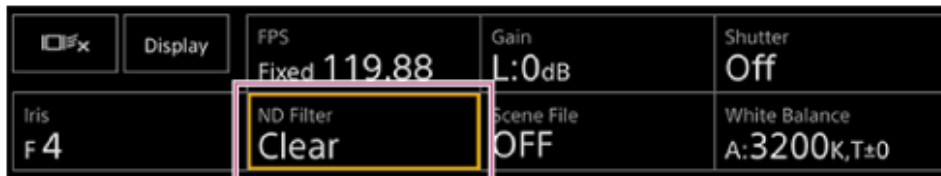

The ND Filter adjustment panel appears.

3 Press the [ND Filter] button and select [Manual] from the list.



4 Adjust the transmittance of the ND filter using the [ND Filter] slider or [ND Filter] adjustment buttons.



Hint

- The slider and adjustment button settings are linked.
- You can also adjust the ND filter on the  (Main) tab in the camera control panel.

To temporarily adjust automatically

You can assign [Push Auto ND] to an assignable button, and temporarily turn auto ND filter on while the button is pressed. Releasing the button sets auto ND filter back to off. Set the ND filter to [Manual].

Note

- When the ND filter is switched to or from [Clear] during shooting, the ND filter frame is displayed on the image and an operating sound is emitted.

Hint

- You can also assign [ND Filter Position] to an assignable button, and press the button to switch between [Manual] and [Clear].

- You can also press the [Push Auto] button on the ND Filter adjustment panel to turn auto ND filter on while the button is pressed.

TP1001804540

5-065-326-11(1) Copyright 2024 Sony Corporation

White Balance Adjustment Screen

You can adjust the white balance using the live operation screen of the Web App to obtain a white balance that makes the image look more natural.

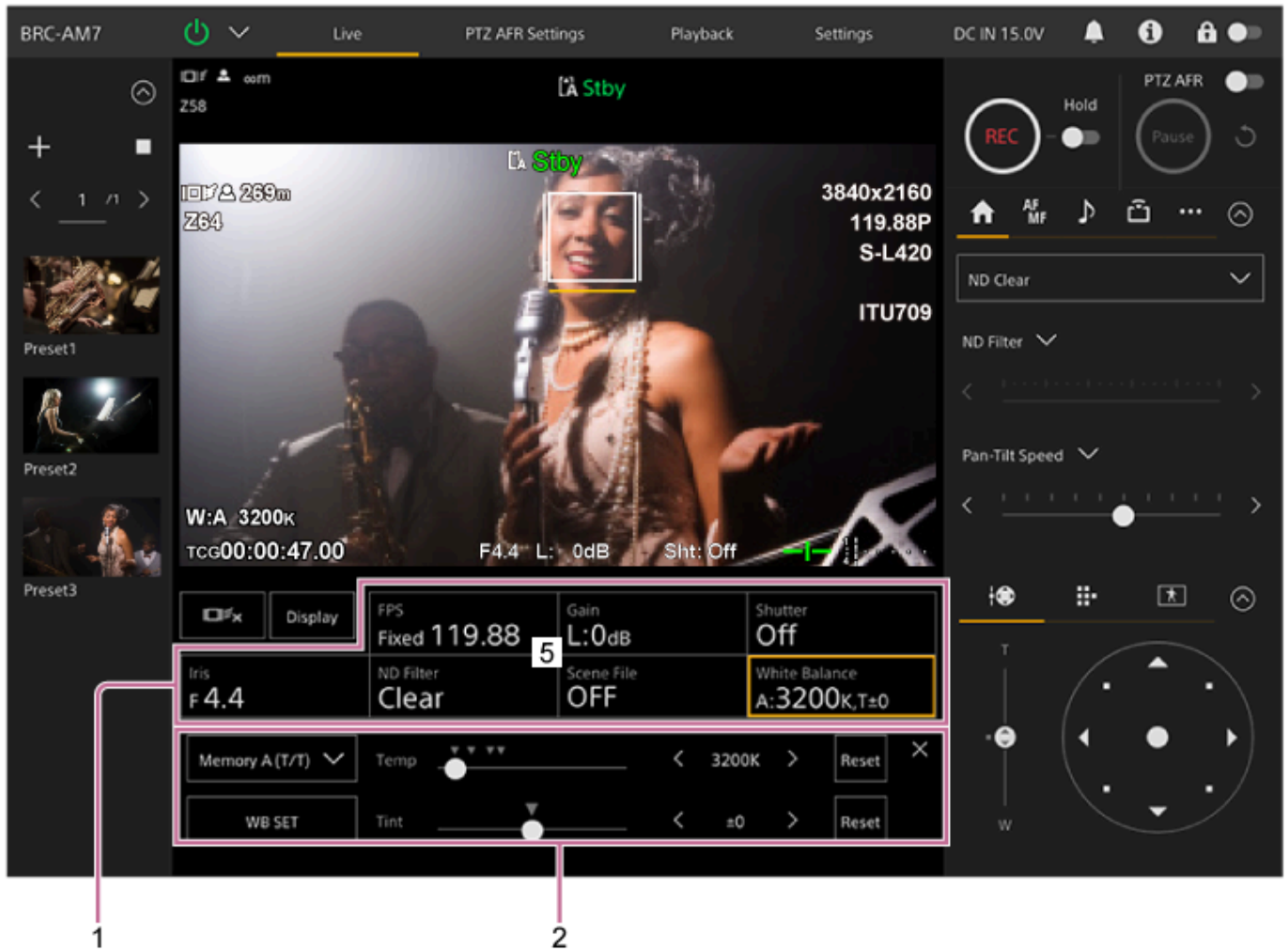

1. Camera basic configuration panel

2. Camera basic configuration adjustment panel

Displays the adjustment panel for the setup item selected on the camera basic configuration panel.

Color Video Camera
BRC-AM7

Adjusting the White Balance Automatically

You can obtain an appropriate adjusted white balance at all times using ATW (auto tracking white balance). When ATW is enabled, the white balance is automatically adjusted as the color temperature of the light source changes.

1 Press the [White Balance] button in the camera basic configuration panel.

The frame of the [White Balance] button changes to orange.



The White Balance adjustment panel appears.

2 Press the [White Mode] button and select [ATW] from the list.

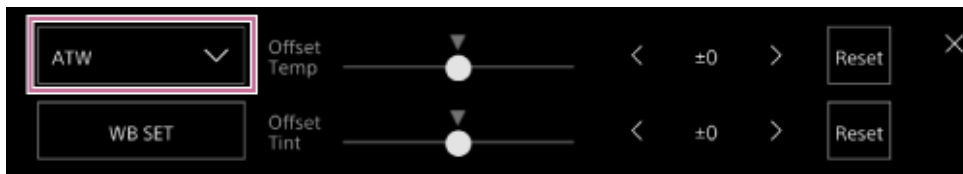

Note

- It may not be possible to adjust to the appropriate color using ATW, depending on the lighting and subject conditions. Examples:
 - When a single color dominates the subject, such as sky, sea, ground, or flowers.
 - When the color temperature is extremely high or extremely low.
- If the ATW auto tracking speed is slow or the appropriate effect cannot be obtained, press the [WB SET] button to run auto white balance.

Hint

- You can select the response speed when in ATW mode from five steps (1, 2, 3, 4, 5) using [Shooting] – [White Setting] – [ATW Speed] in the camera menu. The lower the number, the faster the response speed.
- You can freeze the current white balance setting by assigning the [ATW Hold] function to an assignable button, and pressing the assignable button to temporarily pause ATW during ATW mode.

TP1001804542

Adjusting the White Balance Manually

You can adjust the white balance manually.

1 Press the [White Balance] button in the camera basic configuration panel.

The frame of the [White Balance] button changes to orange.



The White Balance adjustment panel appears.

2 Press the [White Mode] button and select one of the following from the list.

[Memory A (T/T)]



[Memory A (R/B)]

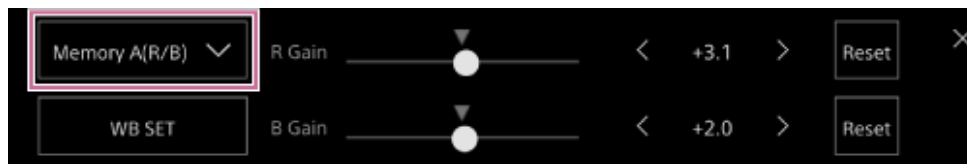

[Preset]



3 Adjust the white balance using the sliders or adjustment buttons.

Hint

- The slider and adjustment button settings are linked.
- The difference between [Memory A (T/T)] and [Memory A (R/B)] is that the axis of adjustment is different, but the adjustment results are linked.

For [Memory A (T/T)]

This mode adjusts the white balance saved in memory A by adjusting the color temperature (Temp) and Tint.

You can set the color temperature in 20 K increments in the range 2000 K to 5600 K. Values above 5600 K can be set at intervals equal to the amount of color change (mired) from 5580 K to 5600 K.

Pressing the [Reset] button on the right side of [Temp] or [Tint] restores the corresponding setting to the default value.

For [Memory A (R/B)]

This mode adjusts the white balance saved in memory A by adjusting the [R Gain] and [B Gain]. Pressing the [Reset] button restores the corresponding gain setting to the default value.

For [Preset]

This mode adjusts the color temperature to a preset value.

You can set the value in 100 K increments.

In preset mode, you can also assign [Preset White Select] to an assignable button, and press the button to change to a preconfigured preset value.

[Custom]: 3200 K → 4300 K → 5600 K → 6300 K → 3200 K...

[Flexible ISO]: 3200 K → 4300 K → 5500 K → 3200 K...

TP1001804543

5-065-326-11(1) Copyright 2024 Sony Corporation

Running Auto White Balance

In memory A mode, the white balance to save is adjusted automatically.

- 1 Press the [White Balance] button in the camera basic configuration panel.

The frame of the [White Balance] button changes to orange.



The White Balance adjustment panel appears.

- 2 Press the [White Mode] button and select [Memory A (T/T)] or [Memory A (R/B)] from the list.

[Memory A (T/T)]

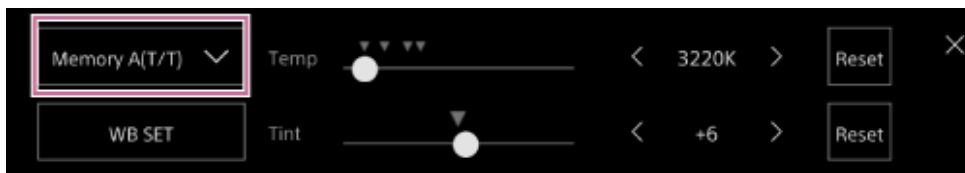

[Memory A (R/B)]

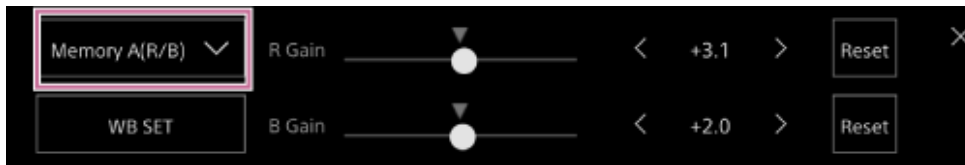

- 3 Place white paper (or other object) in a location with the same lighting source and conditions as the subject, then zoom in on the paper to show white on the screen.

- 4 Adjust the brightness.

Adjust the iris using the procedure in "Adjusting the Iris Manually."

- 5 Press the [WB SET] button on the white balance adjustment panel.

[Memory A (T/T)]



[Memory A (R/B)]

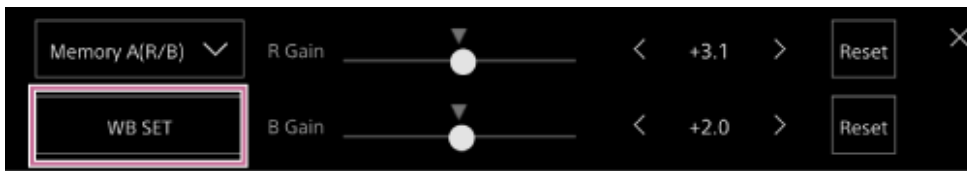

If auto white balance is run in memory mode, the result of auto adjustment is saved in memory A.

Note

- If the adjustment is not successful, an error message is displayed on the screen for about three seconds. If the error message persists after repeated attempts to set white balance, contact your Sony service representative.

Hint

- You can also run it in ATW mode. You can use this when you want to quickly adjust the white balance during ATW operation. After adjustment, the mode returns to normal ATW operation.

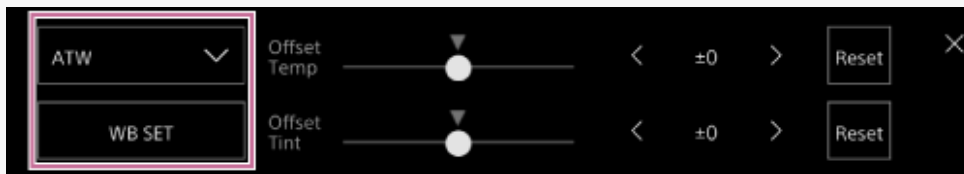

Related Topic

- [Adjusting the Iris Manually](#)

TP1001804544

Audio Configuration Screen

You can adjust the audio level to be recorded by the unit on the live operation screen of the Web App. Configure settings beforehand using the camera menu or web menu.

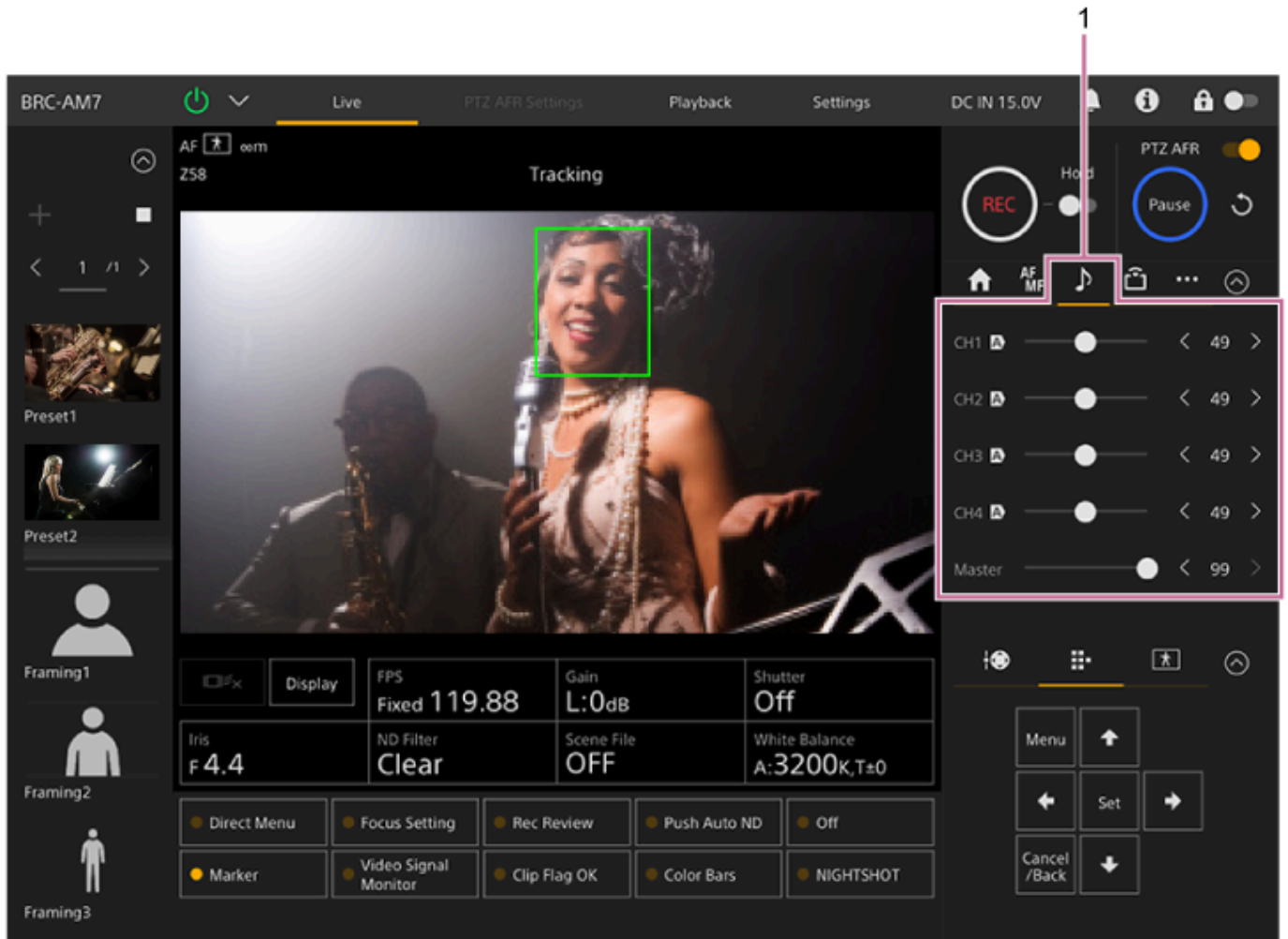

1. Camera control panel – (Audio) tab

TP1001804545

Color Video Camera
BRC-AM7

Selecting the Audio Input Device

Set the following switches according to the device connected to the AUDIO IN connector.

- 1 Set the following to match the type of connected audio input device using [Audio] – [Audio Input] in the web menu.

Item	Setting	Description
[AUDIO IN 1 MIC +48V]	[On]	Enables the AUDIO IN 1 connector +48 V power supply (phantom power supply).
	[Off]	Disables AUDIO IN 1 connector +48 V power supply (phantom power supply).
[AUDIO IN 2 MIC +48V]	[On]	Enables the AUDIO IN 2 connector +48 V power supply (phantom power supply).
	[Off]	Disables AUDIO IN 2 connector +48 V power supply (phantom power supply).

- 2 Select the audio input using [Audio] – [Audio Input] – [CH1 Input Select] to [CH4 Input Select] in the web menu or camera menu.

Note



- Audio is not recorded in Slow & Quick Motion mode.

TP1001804546

Color Video Camera
BRC-AM7

Adjusting the Audio Recording Level Automatically

Set the channel for which you want to adjust the audio recording level automatically to [Auto] on the [Audio] page of the web menu or using [Audio] – [Audio Input] – [CH1 Level Control] to [CH4 Level Control] in the camera menu.

The channels specified for auto adjustment are indicated by an  (Auto) icon beside the corresponding channels on the  (Audio) tab of the live operation screen.

TP1001804547

Color Video Camera
BRC-AM7

Adjusting the Audio Recording Level Manually

You can adjust the audio recording level manually.

- 1 Set the channel for which you want to adjust the audio recording level manually to [Manual] on the [Audio] page of the web menu or using [Audio] – [Audio Input] – [CH1 Level Control] to [CH4 Level Control] in the camera menu.
- 2 Press the  (Audio) tab in the camera control panel.
- 3 On the [Audio] screen in the camera control panel, set the audio recording level using the slider or adjustment buttons for the channel whose audio recording level you want to set manually.

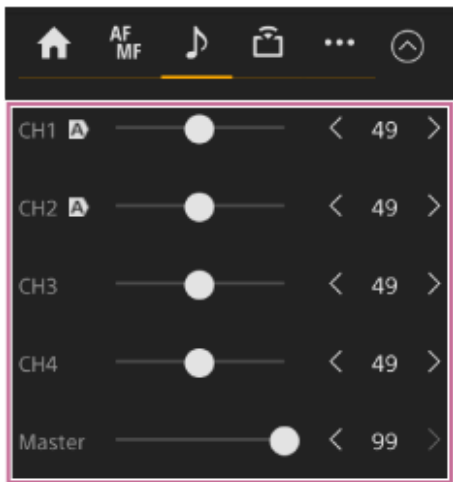

Note

- Channels for which the  (Auto) icon is displayed are adjusted automatically. Changes to values using the slider or buttons are not applied to the recorded audio.

Hint

- The slider and adjustment button settings in each row are linked.
- You can check the audio input level in realtime using the audio level meter display on the shooting screen.

TP1001804548

Color Video Camera
BRC-AM7

Direct Menu Operation

You can check the status and settings of the unit displayed overlaid on the camera image, and select and change the settings using the GUI control buttons on the infrared remote control.

The following items can be configured.

[Subject Recognition AF]

[White Mode]

[Color Temp]

[Scene File]

[ND Filter Position]

[Auto ND Filter]

[ND Filter] value

[Auto Iris]

[Iris] value

[AGC]

[ISO/Gain] value

[Shutter Type]

[Auto Shutter]

[Shutter] value

[Auto Exposure Mode]

[Auto Exposure Level]

[S&Q Motion] and [Frame Rate]

1 Press an assignable button assigned with [Direct Menu] on the infrared remote control.

The [Direct Menu] button is assigned to assignable button 1 by factory default.

Only the items on the screen that can be configured using the direct menu are selectable using the orange cursor.

2 Move the cursor to the item you want to set using the arrow buttons in the GUI control panel and press the [Set] button.

A menu is displayed or the item is displayed on a white background.

3 Select a setting using the arrow buttons and press the [Set] button.

The menu or white background disappears and the new setting is displayed with an orange cursor.

Press an assignable button assigned with the direct menu function again or wait 3 seconds without performing any action to exit the direct menu.

Hint

- You can also perform the same function using an assignable button and the GUI control panel of the Web App.

Color Video Camera
BRC-AM7

Assignable Buttons

There are ten assignable buttons in the Web App of the unit to which you can assign functions. The assignable buttons are displayed on the live operation screen and playback operation screen.

Note

- The list of assignable buttons is not displayed when configuring settings in the camera basic operation panel of the live operation screen. To end the operation, press the [X] button at the top right of the adjustment panel.

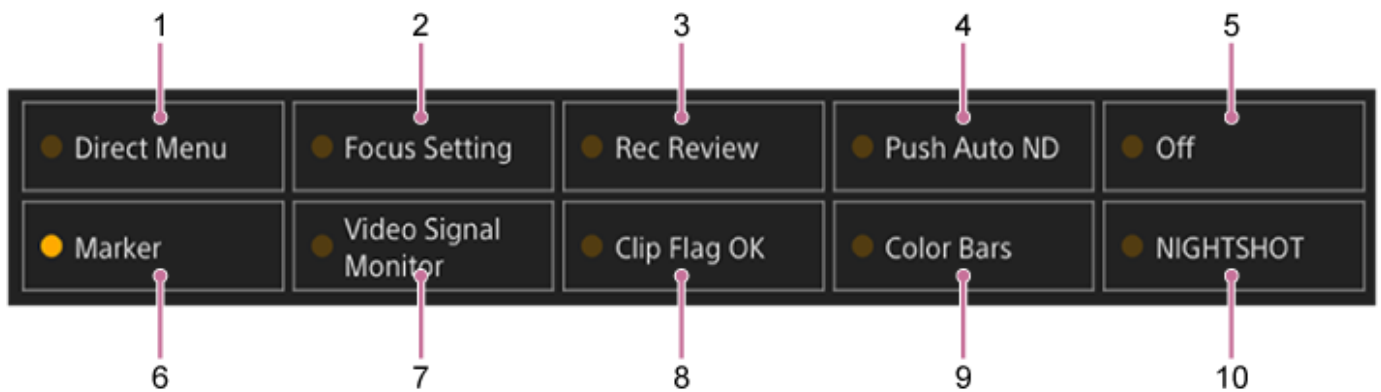

The numbers in the graphic indicate the button numbers.

The following functions are assigned to the buttons by factory default.

Button 1: [Direct Menu]

Button 2: [Focus Setting]

Button 3: [Rec Review]

- Buttons 1 to 3 are equivalent to the same number buttons on the supplied infrared remote control.

Button 4: [Push Auto ND]

Button 5: [Off]

Button 6: [Marker]

Button 7: [Video Signal Monitor]

Button 8: [Clip Flag OK]

Button 9: [Color Bars]

Button 10: [NIGHTSHOT]

To change a button function

Use [Project] – [Assignable Button] in the camera menu.

When you change an assignment, the display of the assignable button list changes.

For details about the assignable functions, see “Assignable Button” in “Camera Menu and Detailed Settings.”

Related Topic

- [\[Assignable Button\]](#)

Color Video Camera
BRC-AM7

Slow & Quick Motion

When the recording format is set to the following values, you can specify different values for the shooting frame rate and playback frame rate.

The following table shows the configurable frame rates.

Recording format			Frame rate
System frequency	Codec	Video format	
59.94/50/23.98	[XAVC HS-L 422]	3840×2160P	1–60, 100, 120
	[XAVC HS-L 420]	3840×2160P	1–60, 100, 120
59.94/50/29.97/25/23.98	[XAVC S-L 422] / [XAVC S-L 420] / [XAVC S-I]	3840×2160P	1–60, 100, 120
		1920×1080P	1–60, 100, 120, 150, 180, 200, 240

Note

- Slow & Quick Motion cannot be set during recording, playback, or while the thumbnail screen is displayed.
- Audio recording is not supported in Slow & Quick Motion mode.
- Auto shutter is disabled in Slow & Quick Motion mode.

TP1001804551

Recording to Memory Cards A and B Simultaneously (2-slot Simul Rec)

You can record to both memory card A and memory card B simultaneously by setting [Project] – [Simul Rec] – [Setting] to [On] in the web menu or camera menu.

Recording separately to memory card A and memory card B



You can start/stop recording to each memory card independently using the record START/STOP button or the [2nd Rec START/STOP] button on the  (Others) tab.

By factory default, both buttons are set to start/stop simultaneous recording to both memory cards A and B.

When the buttons are set to control recording for different memory cards, the [SDI/HDMI Rec Control] record start/stop control follows the recording state of slot A.

Changing the setting

Set the following using [Project] – [Simul Rec] – [Rec Button Set] in the camera menu.

[Rec Button Set] setting	Buttons and memory cards
Rec Button: <Slot A> <Slot B> 2nd Rec Button: <Slot A> <Slot B>	Starts/stops simultaneously recording to memory cards A and B using either button.
Rec Button: <Slot A> 2nd Rec Button: <Slot B>	The record START/STOP button starts/stops recording to memory card A, and the [2nd Rec START/STOP] button on the  (Others) tab starts/stops recording to memory card B.
Rec Button: <Slot B> 2nd Rec Button: <Slot A>	The record START/STOP button starts/stops recording to memory card B, and the [2nd Rec START/STOP] button on the  (Others) tab starts/stops recording to memory card A.

TP1001804552

Color Video Camera
BRC-AM7

Video Signal Monitor

You can set the type of video signal to display in the camera image panel to waveform, vectorscope, or histogram using [Monitoring] – [Video Signal Monitor] – [Setting] in the camera menu.

The orange line indicates the set values of [Level Marker 1] and [Level Marker 2].

You can also assign the [Video Signal Monitor] function to an assignable button.

Monitoring target display

In log shooting mode, the color gamut setting or monitor LUT setting information is displayed at the top right of the video signal monitor to indicate the monitor target.



TP1001804553

Color Video Camera
BRC-AM7

Clip Flags

You can add an [OK] clip flag to a clip by pressing an assignable button assigned with the [Clip Flag OK] function and selecting [Add OK].

You can delete an [OK] clip flag by pressing the button twice to execute [Delete Clip Flag].

Hint

- You can also add a clip flag using [Thumbnail] – [Set Clip Flag] in the camera menu.
- The thumbnail screen can be displayed sorted by clip flag type (filtered clip thumbnail screen). For details, see “Operations on Recorded Clips” in “Thumbnail Screen.”

TP1001804554

Color Video Camera
BRC-AM7

Proxy Recording Overview

This function allows you to simultaneously record low-resolution proxy data at the same time as recording high-resolution original data video.

- For details about supported memory cards, formatting memory cards, and checking the remaining capacity, see “Recommended Memory Cards” in “Preparing Memory Cards.”

About the recorded file

The file name extension is “.mp4”.

The timecode is also recorded simultaneously.

Storage destination of the recorded file

The recorded file is stored in the following directory.

Recording media	Folder path
SDXC	/PRIVATE/M4ROOT/Sub
CFexpress Type A	/M4ROOT/Sub

About the file name

- The file name consists of the clip name recorded on the memory card and an “S03” suffix.
- For clip names, see [TC/Media] – [Clip Name Format] in the camera menu.

Related Topic

- [Recommended Memory Cards](#)

TP1001804555

Color Video Camera
BRC-AM7

Recording a Proxy

You can start recording when proxy recording is enabled.

1 Set [Project] – [Proxy Rec] – [Setting] to [On] in the web menu or camera menu.

2 Insert a memory card into a CFexpress Type A / SD card slot.

For CFexpress cards, insert with the label facing up.

For SD cards, insert with the label facing down.

Note

- Proxy recording cannot be turned on at the same time as Slow & Quick Motion. When Proxy Rec is set to on, these other recording modes are forcibly set to off.

3 Press the record START/STOP button.

Proxy recording starts.

Note

- If the unit is turned off or the memory card is removed while the memory card is being accessed, the integrity of data on the card cannot be guaranteed.
All data recorded on the memory card may be discarded. Always make sure the memory card access indicator is off before turning off the unit or removing the memory card.
- Make sure that the memory card does not pop out when inserting or removing it.

To stop shooting

Stop the recording.

To set the audio channel for proxy recording

Set the audio channel for proxy data recording using [Project] – [Proxy Rec] – [Audio Channel] in the camera menu.

Hint

- You can perform file transfer of recorded proxy clips automatically. For details, see “Transferring Recorded Proxy Clips Sequentially.”

Related Topic

- [Transferring Recorded Proxy Clips Sequentially](#)

TP1001804556

Color Video Camera
BRC-AM7

Look Overview

When the unit is in custom mode, you can add adjustments to the black, matrix, and other parameters to create a “look” based on the base look.

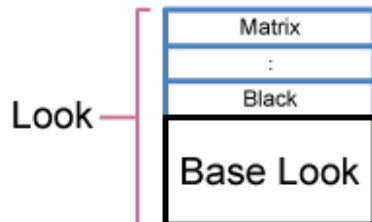

You can also quickly select a different look by saving different combinations of settings in scene files. The unit is provided with a total of six preset looks.

TP1001804557

Selecting a Look

This topic describes how to select a look.

- 1 Check that [Project] – [Base Setting] – [Shooting Mode] is set to [Custom] in the web menu or camera menu.

Hint

- In [Custom] mode, the [Scene File] button is displayed in the camera basic configuration panel.

- 2 Press the [Scene File] button in the camera basic configuration panel.

The frame of the [Scene File] button changes to orange.

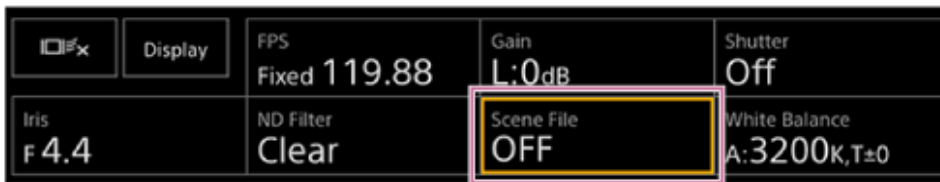

The Scene File adjustment panel appears.

- 3 Press the [Scene File] button on the adjustment panel and select a scene file with the desired look from the list.

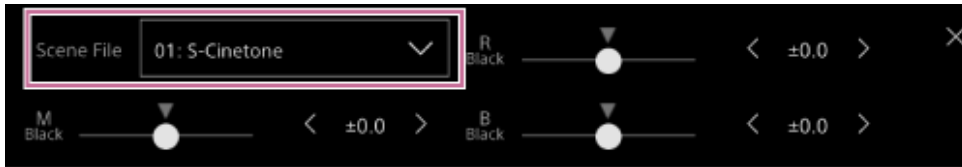

The following presets are configured by factory default.

[Target Display]	[SDR(BT.709)]	[HDR(HLG)]
Scene file 1	[S-Cinetone]	[HLG Live]
Scene file 2	[ITU709]	[HLG Mild]
Scene file 3	[709tone]	[HLG Natural]
Scene files 4 to 16	(Not registered)	(Not registered)

Hint

- You can also select a look using [Paint/Look] – [Scene File] – [Recall] in the camera menu. You can also recall a preset look using [Scene File] – [Preset Recall].

Importing a Desired Base Look

You can import a 3D LUT file, created on a computer or other device, as a base look. Up to 16 files can be imported.
File format: CUBE file (*.cube) for a 17-grid or 33-grid 3D LUT created using Catalyst Browse or DaVinci Resolve* (by Blackmagic Design Pty. Ltd.).

* Verified with Resolve V9.0, V10.0, and V11.0.

- Input color gamut/Gamma: [S-Gamut3.Cine/S-Log3] or [S-Gamut3/S-Log3]

1 Save the 3D LUT file on the device running the Web App.

2 Open [Paint/Look] – [Base Look] in the web menu.

A list of registered base looks appears.

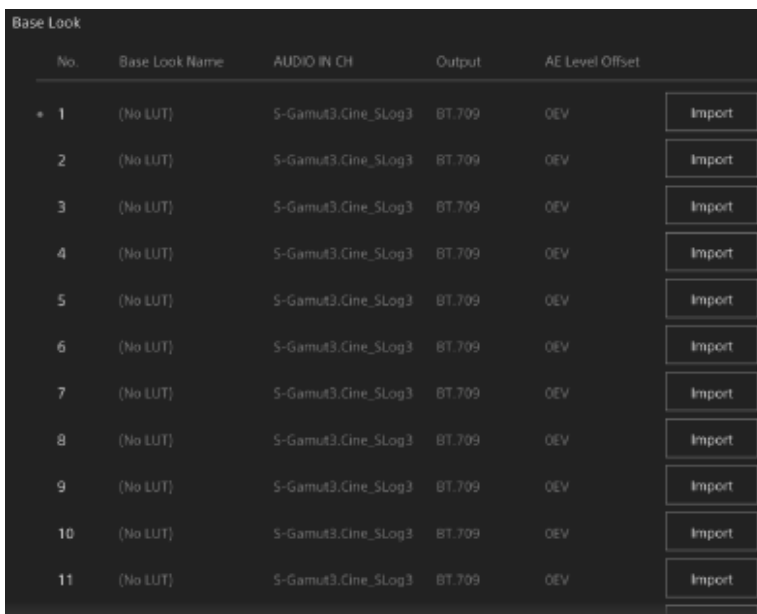

No.	Base Look Name	AUDIO IN CH	Output	AE Level Offset	
* 1	(No LUT)	S-Gamut3.Cine_SLog3	BT.709	0EV	Import
2	(No LUT)	S-Gamut3.Cine_SLog3	BT.709	0EV	Import
3	(No LUT)	S-Gamut3.Cine_SLog3	BT.709	0EV	Import
4	(No LUT)	S-Gamut3.Cine_SLog3	BT.709	0EV	Import
5	(No LUT)	S-Gamut3.Cine_SLog3	BT.709	0EV	Import
6	(No LUT)	S-Gamut3.Cine_SLog3	BT.709	0EV	Import
7	(No LUT)	S-Gamut3.Cine_SLog3	BT.709	0EV	Import
8	(No LUT)	S-Gamut3.Cine_SLog3	BT.709	0EV	Import
9	(No LUT)	S-Gamut3.Cine_SLog3	BT.709	0EV	Import
10	(No LUT)	S-Gamut3.Cine_SLog3	BT.709	0EV	Import
11	(No LUT)	S-Gamut3.Cine_SLog3	BT.709	0EV	Import

3 Press the [Import] button in the row where you want to import the file.

The file selection dialog appears.

4 Select the prepared 3D LUT file.

The imported 3D LUT file becomes the base look of the unit.

5 Select the imported 3D LUT file using [Paint/Look] – [Base Look] – [Select] in the camera menu.

6 Configure [Paint/Look] – [Base Look] – [Input] and [Output] in the camera menu to match the attributes of the imported 3D LUT file.

To adjust for underexposure

If there is a tendency for underexposure when auto exposure is selected when using the imported base look, adjust the look using [Paint/Look] – [Base Look] – [AE Level Offset] in the web menu.

Note

- Just importing a 3D LUT file does not affect the image. Select the imported 3D LUT file using [Paint/Look] – [Base Look] – [Select] in the camera menu.
- If [Input] is not set correctly, the proper look will not be obtained.
- The [Input], [Output], and [AE Level Offset] menu item settings are applied to the base look selected using [Select]. If multiple 3D LUT files are imported, select each 3D LUT file using [Select], and configure [Input], [Output], and [AE Level Offset] individually for each file.
- The configured [Input], [Output], and [AE Level Offset] settings are saved for each 3D LUT file.
- The base look/LUT selection options for imported 3D LUT files are common to [SDR(BT.709)], [HDR(HLG)], and log shooting mode, but color gamut and gamma conversion are not performed according to these modes.
- 3D LUT files are not deleted when [Maintenance] – [Reset] – [All Reset (except for Network Settings)] is executed in the web menu.
- A  (3D LUT file attachment error) displayed in front of the [Base Look Name] display indicates that 3D LUT files cannot be attached to clips recorded in log shooting mode. Import the 3D LUT file again.

TP1001804559

Color Video Camera
BRC-AM7

Customizing a Look

You can customize the look based on the base look using the [Master Black], [R Black], and [B Black] sliders in the Scene File adjustment panel in the camera basic configuration panel and [Paint/Look] – [Matrix] and other setup items in the camera menu.

Connect the unit to a TV or monitor, and adjust the picture quality while observing the picture on the TV or monitor screen.

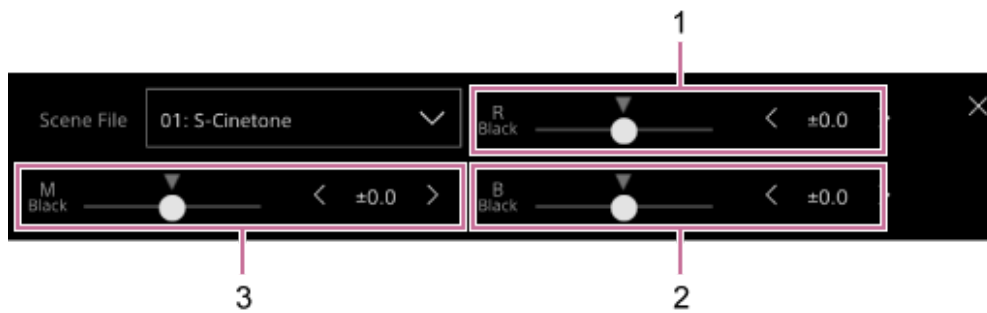

- 1: [R Black] slider/adjustment buttons
- 2: [B Black] slider/adjustment buttons
- 3: [Master Black] slider/adjustment buttons

Note

- When you import a 3D LUT file and apply it to the image, the desired look defined in the 3D LUT file will not be obtained if [Paint/Look] – [Matrix] and settings other than the base look settings in the camera menu are changed.
- You can reset all customized settings using [Paint/Look] – [Reset Paint Settings] – [Reset without Base Look] in the camera menu.

TP1001804560

Color Video Camera
BRC-AM7

Saving a Look

You can save the current look as a scene file in internal memory using [Paint/Look] – [Scene File] – [Store] in the camera menu.

You can quickly recall a saved look using the Scene File adjustment panel or using direct menu operations.

Note

- If you select another look without saving the current look, the current look is discarded.

Hint

- You can overwrite the preset scene files. To restore a preset scene file, load the look to be restored using [Paint/Look] – [Scene File] – [Preset Recall] in the camera menu, and then save the scene file using [Scene File] – [Store].

To delete a saved look

You can delete a scene file saved in internal memory using [Paint/Look] – [Scene File] – [Delete] in the camera menu.

Hint

- When deleted, it is no longer displayed in the Scene File adjustment panel or the direct menu.

TP1001804561

Color Video Camera
BRC-AM7

Deleting a Base Look

You can delete imported 3D LUT files individually using [Paint/Look] – [Base Look] – [Delete] in the camera menu.

You can delete all imported 3D LUT files using [Paint/Look] – [Base Look] – [Delete All] in the camera menu.

Note

- Before deleting, check that the base look is not being used in any scene files. If a base look that is being used is deleted, the look of the corresponding scene files will be incorrect.
- Imported 3D LUT files are not deleted when [Maintenance] – [Reset] – [All Reset (except for Network Settings)] is executed in the web menu.
- A deleted base look can no longer be used as a LUT in log shooting mode.

TP1001804562

Color Video Camera
BRC-AM7

Shooting with Look Adjustment in Post-Production

By using the unit in log shooting mode^{*1} and recording gradations evenly from dark areas to bright areas, you can make fine adjustments, such as locally restoring the gradations of dark areas and bright areas, in post-production.

However, when viewing the recorded images on a conventional monitor, the overall contrast will appear low, making focus and exposure adjustments difficult.

You can apply a LUT to the monitor target on the unit to assist various adjustments during shooting. You can also apply the LUT used when shooting automatically upon playback to quickly check the finished result.

LUTs are applied by the following systems. However, only one LUT can be applied.

- SDI1 output
- SDI2 output/HDMI output and streaming
- Proxy clip recorded on recording media
- High-res (main) clip recorded on recording media

^{*1} Generic term for Flexible ISO mode/Cine EI mode/Cine EI Quick mode. The unit supports Flexible ISO mode.

TP1001804563

Color Video Camera
BRC-AM7

Applying a LUT to SDI2 Output/HDMI Output and Streaming

You can apply a LUT to SDI2 output/HDMI output and streaming.

- 1 Check that [Project] – [Base Setting] – [Shooting Mode] is set to [Flexible ISO] in the web menu or camera menu.

Hint

- In log shooting mode, the [Base Look/LUT] button is displayed in the camera basic configuration panel.

- 2 Press the [Base Look/LUT] button in the camera basic configuration panel.

The frame of the [Base Look/LUT] button changes to orange.

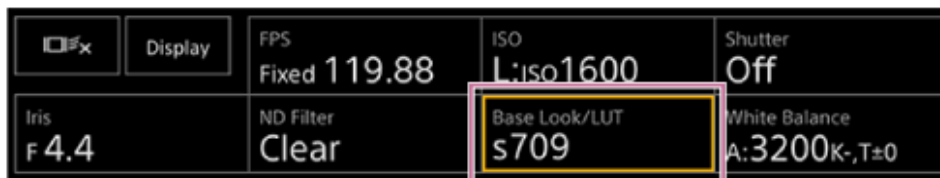

The Base Look/LUT adjustment panel appears.

- 3 Select [SDI2/HDMI/Stream] – [MLUT].

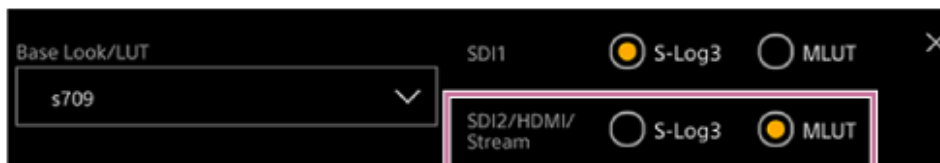

Note

- The image in the Web App camera image panel is also included in the streaming image.

Hint

- This can also be set using [Shooting] – [LUT On/Off] – [SDI2/HDMI/Stream] in the camera menu.
- SDI1 output can be set in the same way.
- You can set proxy clip video settings using [Shooting] – [LUT On/Off] – [Proxy] in the camera menu.
- A  (3D LUT file attachment error) displayed in front of the [Base Look/LUT] display indicates that 3D LUT files cannot be attached to clips recorded in log shooting mode. Import the 3D LUT file again. This icon is also displayed when attachment fails due to temporary processing congestion.

Color Video Camera
BRC-AM7

Changing a LUT

You can change the LUT to apply.

- 1 Press the [Base Look/LUT] button in the camera basic configuration panel.

The frame of the [Base Look/LUT] button changes to orange.

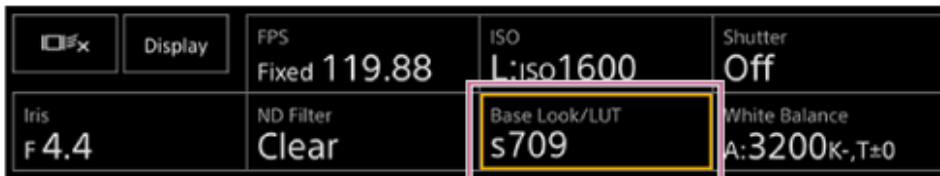

The Base Look/LUT adjustment panel appears.

- 2 Press the [Base Look/LUT] button and select the base look to apply.

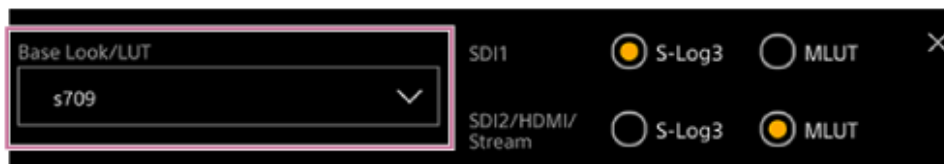

Hint

- The unit provides [s709], [709(800%)], and [S-Log3] as preset LUTs.
- You can also import and apply a 3D LUT file. For details, see “Importing a Desired Base Look” and “Deleting a Base Look.”
- This can also be set using [Paint/Look] – [Base Look] – [Select] in the camera menu.

Related Topic

- [Importing a Desired Base Look](#)
- [Deleting a Base Look](#)

TP1001804565

Color Video Camera
BRC-AM7

Saving and Loading Configuration Data Overview

You can save the settings of the unit as configuration data using the Web App. This allows you to quickly recall an appropriate set of menu settings for the current situation.

With this unit, you can save almost all settings related to camera functions, other than the following note, as an ALL file (file with all settings).

Note

- Settings related to the pan/tilt, network function settings, and authentication information are not saved. For details about saved items, see "List of Menu Items."

Related Topic

- [List of Menu Items](#)

TP1001804566

Color Video Camera
BRC-AM7

Saving an ALL File

This topic describes how to save an ALL file.

1 Open [Project] – [All File] in the web menu.

2 Press the [Save All File] – [Save] button.

The web browser will download a file named all-file.ALL momentarily.

3 Specify a location and file name for the downloaded all-file.ALL file, and save the file.

For details about file operations, refer to the operating instructions of your device.

TP1001804567

Color Video Camera
BRC-AM7

Loading an ALL File

This topic describes how to load an ALL file.

Note

- The unit will reboot automatically after loading configuration data. After rebooting, reload the page in the web browser.

- 1 Open [Project] – [All File] in the web menu.**
- 2 Press the [Load All File] – [Load] button.**

The open file dialog appears on the device running the Web App.
- 3 Open the file you want to load.**

For details about file operations, refer to the operating instructions of your device.
- 4 When the load file name confirmation screen appears, press the [OK] button.**
- 5 When the execution result screen appears, press the [OK] button.**
- 6 Wait for the unit to reboot, then reconnect the Web App.**

TP1001804568

Color Video Camera
BRC-AM7

About File Transfer

You can transfer a proxy clip or original clip recorded on the unit to a server on the Internet or to a server on the local network.

Note

- When the power supply is set to standby state, file transfers are placed on hold even though the unit is still powered.

TP1001804569

Registering a File Transfer Destination

You can register a transfer destination server before starting a file transfer.

- 1 Select **[Network] – [File Transfer] – [Default Upload Server] – [Server Settings1] (or [Server Settings2], [Server Settings3])** in the web menu.

Hint

- The name of the selection option will change according to [Display Name] configured in the next step.

- 2 Configure the following items for **[Network] – [FTP Server 1] to [FTP Server 3]** in the web menu.

Item	Description
[Display Name]	Enter the name of the server to display in the transfer job list when selecting a transfer destination server.
[Service]	Displays the server type. [FTP]: FTP server
[Host Name]	Enter the address or host name of the server.
[Port]	Enter the port number of the server to connect.
[User Name]	Enter the user name.
[Password]	Enter the password.
[Passive Mode]	Turn passive mode on/off.
[Destination Directory]	Enter the name of the directory on the destination server. Note • If characters that are invalid on the destination server are entered in [Destination Directory], files will be transferred to the user's home directory. Invalid characters will vary depending on the server.
[Using Secure Protocol]	Set whether to perform secure FTP transfer.
[Root Certificate]	Load/clear a certificate. [Load]: Load a CA certificate. Loads PEM-format certificates. [Clear]: Clear the CA certificate. [None]: Do not load or clear a certificate. Note • Set the clock of the unit to the correct time before loading a CA certificate. • When recording in 3840×2160P 59.94/50P, [Load] cannot be selected. [Root Certificate Status]: Displays the load status of the certificate. [Reset]: Resets the [Server Settings] settings to the default values.

Color Video Camera
BRC-AM7

Transferring Recorded Proxy Clips Sequentially

You can reserve file transfer of recorded proxy clips automatically as soon as the recording of the proxy clips end. They are uploaded to the server specified using [Default Upload Server] at the instant recording stops.

- 1 **Set [Network] – [File Transfer] – [Auto Upload (Proxy)] to [On] in the web menu or camera menu.**
- 2 **Press the record button to start/stop recording.**

The recorded proxy clips are registered as transfer jobs, and then uploaded sequentially.
For details about proxy recording, see “Proxy Recording Overview.”

Hint

- Up to 200 transfer jobs can be registered.

Related Topic

- [Proxy Recording Overview](#)

TP1001868327

Uploading a Proxy Clip on a Memory Card from the Thumbnail Screen

You can upload proxy clips on a memory card individually from the thumbnail screen.

- 1 Press the [Thumbnail] button on the live operation screen of the Web App.**

The display changes from the camera image to the thumbnail screen.
- 2 Select [Thumbnail] – [Transfer Clip (Proxy)] – [Select Clip] in the camera menu.**

To transfer all proxy clips simultaneously, select [Transfer Clip (Proxy)] – [All Clips].
Clips can be transferred from the thumbnail screen or the filtered clip thumbnail screen.
- 3 Select the clip you want to transfer using the [Set] button, and press the [Menu] button.**

A transfer confirmation screen appears.
- 4 Select [Execute].**

The file corresponding to the selected clip is registered as a transfer job, and uploading begins.
When the transfer job is successfully registered, the transfer result screen appears.
- 5 Press the [OK] button.**

Note

- Up to 200 transfer jobs can be registered.

Uploading an Original Clip on a Memory Card from the Thumbnail Screen

You can upload an original clip on a memory card from the thumbnail screen.

- 1 Press the [Thumbnail] button on the live operation screen of the Web App.**

The display changes from the camera image to the thumbnail screen.
- 2 Select [Thumbnail] – [Transfer Clip] – [Select Clip] in the camera menu.**

To transfer all original clips simultaneously, select [Transfer Clip] – [All Clips].
Clips can be transferred from the thumbnail screen or the filtered clip thumbnail screen.
- 3 Select the clip you want to transfer using the [Set] button, and press the [Menu] button.**

A transfer confirmation screen appears.
- 4 Select [Execute].**

The original clip of the selected clip is registered as a transfer job, and uploading begins.
When the transfer job is successfully registered, the transfer result screen appears.
- 5 Press the [OK] button.**

Note

- Up to 200 transfer jobs can be registered.

Color Video Camera
BRC-AM7

Checking the File Transfer Status

You can check the status of file transfer by selecting [Network] – [File Transfer] – [View Job List] in the camera menu.

Note

- Up to 200 transfer jobs can be registered.
- The transfer jobs are retained when the unit is switched to standby state, but up to 10 minutes of recent progress information may be lost if the power is disconnected by any other means.
- If an error occurs during file transfer, the transfer of a clip with the same name as a transferred clip may not be resumed depending on the settings and status of the transfer destination server. In this case, check the transfer destination server settings and status.
- When a new transfer job is registered, successfully completed transfer jobs are removed from the job list.

TP1001804573

Color Video Camera
BRC-AM7

Uploading Using Secure FTP

You can upload files with encryption using FTPS in Explicit mode (FTPES) for the connection with the destination file server. For secure FTP transfer, set [Using Secure Protocol] to [On] in the destination file server settings and load a certificate.

- For details about configuration, see “Registering a File Transfer Destination.”
-

Related Topic

- [Registering a File Transfer Destination](#)

TP1001804574

About Streaming

The unit can simultaneously stream the video and audio that is output from the HDMI connector.

Note

- To use streaming as the main video, set [Monitoring] – [Output Display] – [SDI1] to [On] and [SDI2/HDMI/Stream] to [Off] in the web menu, and monitor the camera status on an SDI monitor.
- If a monitor connected to the HDMI connector does not support the HDMI output format configured using the [Monitoring] menu in the web menu or camera menu, the camera image will not be output to the Web App. Streaming video also cannot be output.
- The streaming resolution cannot be set higher than the HDMI output signal resolution.
- When viewed by multiple users, the image may become distorted depending on the codec settings.

The unit supports the following streaming methods. The video codecs available for selection are shown in parentheses.

- RTSP (H.264, H.265)
- RTMP (H.264)^{*1}
- SRT-Caller (H.264)
- SRT-Listener (H.264)
- NDI|HX (H.264, H.265)

Configure the streaming format setting, video codec setting, and audio codec setting in that order.

Streaming format	Codec setting			
	[Video Stream 1]	[Video Stream 2]	[Video Stream 3]	[Audio Stream]
RTSP	● video 1	● ^{*2} video 2	–	●
RTMP	●	–	–	● ^{*1}
SRT	●	–	–	●
NDI HX	● Main	● Sub	–	●
Web App	–	–	●	–

●: Enabled, –: Disabled

^{*1} RTMP can be selected when [Stream] – [Audio Stream] is set to [On] in the web menu.

^{*2} When the system frequency is 59.94 or 50 and the HDMI output format is 3840×2160 or higher, video 2 output is not available.

Hint

- The image in the Web App camera image panel is also a streaming system.

Color Video Camera
BRC-AM7

Setting the Streaming Format

Set the streaming format using [Stream] – [Stream] – [Stream Setting] – [Setting] in the web menu.

When [Setting] is set to [RTSP]

In RTSP streaming, the image from a single camera can be viewed simultaneously by up to five users. You can set up to two video codec modes.

Item	Description
[Port Number]	Sets the port number to use for RTSP streaming. The default value is 554. Changing the setting will reboot the RTSP server.
[Time Out]	Specifies the timeout time of the Keep-Alive command for RTSP streaming. The timeout time can be set in the range 0 seconds to 600 seconds. The default value is 60 seconds. When set to 0 seconds, timeout due to the Keep-Alive command does not occur.
[Authentication]	Sets whether authentication is required.
[Video Port Number 1] [Video Port Number 2]	Specifies the image data communications port number to use for RTSP unicast streaming. The factory default value for Video Port Number 1 is 51000. The factory default value for Video Port Number 2 is 53000. Specify an even number in the range 1024 to 65534. The number set here and the subsequent odd number, obtained by adding 1, become the two port numbers used for image data communications and control. [Video Port Number 1] and [Video Port Number 2] correspond to [Stream] – [Video Stream] – [Video Stream 1] and [Video Stream 2].
[Audio Port Number]	Specifies the audio data communications port number used for RTSP unicast streaming. The default value is 57000. Specify an even number in the range 1024 to 65534. The number set here and the subsequent odd number, obtained by adding 1, become the two port numbers used for audio data communications and control.

When [Setting] is set to [RTMP]

To use RTMP, [Stream] – [Audio Stream] must be set to [On] in the web menu. The video codec mode that can be used for RTMP is H.264 only.

Item	Description
[Server URL]	Sets the upload destination URL. Specify a character string beginning with "rtmp://" or "rtmps://".
[Stream Key]	Enter the stream key obtained from the site you are using. Pressing the [Clear] button will clear the entry. Note ● Exercise caution when handling the stream key. If the stream key is known by a third party, there is a risk of spoofing the stream.

Item	Description
[Root Certificate]	<p>Imports the root certificate required for streaming using the RTMPS protocol. To import the root certificate, press the [Load] button and select and apply a root certificate. The certificate is imported into the unit. If there is an imported root certificate in the unit, the root certificate will be updated. To delete an imported root certificate, press the [Delete] button on the setup screen. The root certificate status is displayed in [Root Certificate Status].</p> <p>Note</p> <ul style="list-style-type: none"> ● Import the root certificate required by the streaming service.

When [Setting] is set to [SRT-Caller] or [SRT-Listener]

The video codec mode is H.264 only.

Item	Description
[Destination]	Displayed when the streaming mode is set to [SRT-Caller]. Sets the connection destination URL.
[Port Number]	Displayed when the streaming mode is set to [SRT-Listener]. Sets the port number on which to listen. The default value is 4201.
[Latency]	Sets the latency in the range 20 ms to 8000 ms. The default value is 120.
[TTL]	Sets the TTL value in the range 1 to 255. The default value is 64.
[Encryption]	Selects the encryption method. Select Off, AES128, or AES256. The default value is Off.
[Passphrase]	Sets the passphrase used for encryption. Pressing the [Clear] button will reset the configured passphrase.
[ARC]	To enable the Adaptive Rate Control function, set to on. When the Adaptive Rate Control function is enabled, interruptions in the image caused by communication line congestion can be reduced.

When [Setting] is set to [NDI|HX]

The unit complies with NDI|HX version 2 from NewTek.

Note

- Download the latest NDI|HX driver and install it in a NewTek product.
- For details about NDI|HX registration and operation, refer to the operating instructions for the NewTek product.

Item	Description
[Source Name]	Displays the source name.
[Group]	To enable the NDI grouping function, set to on. [Group Name]: Sets the NDI group name. Multiple settings can be configured separated by a comma.
[Discovery Server 1] [Discovery Server 2]	Sets NDI discovery server 1 and NDI discovery server 2.
[Reliable UDP Mode]	To enable Reliable UDP mode, set to on.

Item	Description
[Multicast Mode]	To enable multicast streaming, set to on. [Multicast Prefix]: Sets the prefix to use for multicast streaming. [Multicast Netmask]: Sets the netmask that determines the multicast address range. [Multicast TTL]: Sets the TTL value for multicast streaming in the range 1 to 256. The default value is 3.
[Multi-TCP Mode]	To enable Multi-TCP mode, set to on.
[Unicast UDP Mode]	To enable Unicast UDP mode, set to on.

About 3rd-party services and software

Different terms of use may apply.

- The provision of services and software updates may be interrupted or terminated without notice.
- The description of services and software is subject to change without notice.
- Separate registration and subscription may be required.

Sony will not be liable for any claims made by users or a third party due to the use of services and software of other companies.

TP1001804576

Setting the Video Codec for Streaming

Set the video codec using [Stream] – [Video Stream] in the web menu.

Item	Description
<p>[Video Stream 1] [Video Stream 2] [Video Stream 3]</p>	<p>You can set up to three image codec modes. Configure the following settings separately for each image mode. [Video Stream 3] is used for the Web App camera image panel display.</p> <p>Note</p> <ul style="list-style-type: none"> When [Stream] – [Stream Setting] – [Setting] is set to [RTMP], [SRT-Caller], or [SRT-Listener], some of the [Video Stream 1], [Video Stream 2], and [Video Stream 3] settings ([Codec], [Size], [Frame Rate], [Bit Rate Compression Mode]) have default values.
<p>[Codec 1] [Codec 2] [Codec 3]</p>	<p>Select [H.264], [H.265], or [Off]. Note that [Codec 1] cannot be set to [Off]. Also, [Codec 3] is set to [JPEG] (fixed).</p> <p>Note</p> <ul style="list-style-type: none"> The following symptoms may occur depending on the combination of various settings, such as the picture size, frame rate, and bit rate of [Codec 1], [Codec 2], and [Codec 3]. <ul style="list-style-type: none"> Increased video latency. Frame skipping during video playback. Intermittent audio. Slow camera response to various commands. Slow camera response to operations from a remote controller. Slow monitor screen display and configuration operations. <p>If you experience these symptoms, reduce the values of the picture size, frame rate, and bit rate parameters, or change the values of other setup parameters to resolve the issue.</p> <ul style="list-style-type: none"> When [Stream] – [Stream Setting] – [Setting] is set to [RTMP], [SRT-Caller], or [SRT-Listener], [Codec 1] is set to [H.264] (fixed). [Codec 2] is set to [Off] (fixed). When the picture size or system frequency of the HDMI output is changed, [Codec 2] is set to [Off].
<p>[Size 1] [Size 2] [Size 3]</p>	<p>Selects the picture size to stream from the camera. The available picture size options will vary depending on the picture size of the HDMI output.</p> <p>Note</p> <ul style="list-style-type: none"> When the picture size or system frequency of the HDMI output is changed, the maximum picture size will be selected.

Item	Description
[Frame Rate 1] [Frame Rate 2] [Frame Rate 3]	<p>Sets the frame rate of the image. “fps” units indicate the number of frames streamed per second. The available frame rate options will vary depending on the picture size of the HDMI output.</p> <div style="background-color: #f0f0f0; padding: 10px; border: 1px solid #ccc;"> <p>Note</p> <ul style="list-style-type: none"> When the picture size or system frequency of the HDMI output is changed, the maximum frame rate will be selected. </div>
[I-Picture Mode 1] [I-Picture Mode 2]	<p>Sets the method for specifying the I-picture insertion interval for H.264 and H.265 to [Time] or [Frame]. Cannot be set for [Codec 3]. [Time]: Sets the I-picture insertion interval as a time. [Frame]: Sets the I-picture insertion interval as a number of frames.</p> <div style="background-color: #f0f0f0; padding: 10px; border: 1px solid #ccc;"> <p>Hint</p> <ul style="list-style-type: none"> The shorter the I-picture insertion interval, the better the image quality will become, but the bit rate will increase. </div>
[I-Picture Interval 1] [I-Picture Interval 2]	<p>Sets the I-picture insertion interval in units of seconds. Sets a value in the range 1 second to 5 seconds. The default value is 1 second. Configurable when [I-Picture Mode 1] and [I-Picture Mode 2] are set to [Time]. Cannot be set for [Codec 3].</p>
[I-Picture Ratio 1] [I-Picture Ratio 2]	<p>Sets the I-picture insertion interval for H.264 and H.265 as a number of frames in the range 15 to 300. The default value is 300 frames. Configurable when [I-Picture Mode 1] and [I-Picture Mode 2] are set to [Time]. Cannot be set for [Codec 3].</p>
[Profile 1] [Profile 2]	<p>Sets the H.264 or H.265 image codec profile. [H.264]: Select [high], [main], or [baseline] profile. [H.265]: Limited to [main]. Image compression efficiency increases in the order of [high], [main], and [baseline]. Select a profile supported by your system. Cannot be set for [Codec 3].</p>
[Bit Rate Compression Mode 1] [Bit Rate Compression Mode 2]	<p>Select [CBR] or [VBR]. To maintain a constant bit rate, select [CBR]. To maintain image quality, select [VBR]. Cannot be set for [Codec 3].</p> <div style="background-color: #f0f0f0; padding: 10px; border: 1px solid #ccc;"> <p>Note</p> <ul style="list-style-type: none"> The frame rate and bit rate actually streamed may differ from the set values, depending on the picture size, shooting scene, network environment, and other factors. When [Stream] – [Stream Setting] – [Setting] is set to [RTMP], [SRT-Caller], or [SRT-Listener], [Bit Rate Compression Mode 1] is set to [CBR] (fixed). </div>
[Bit Rate 1] [Bit Rate 2]	<p>You can set the bit rate per video stream when [Bit Rate Compression Mode] is set to [CBR]. Setting a high bit rate allows you to stream high image quality video. Cannot be set for [Codec 3].</p>

Item	Description
[Quality 1] [Quality 2] [Quality 3]	<p>Sets the image quality in the range 1 to 10. A value of 10 sets the highest image quality. The default value is 6.</p> <p>For [Quality 1] and [Quality 2], you can set H.264 image quality by setting [Bit Rate Compression Mode] to [VBR] and [Codec] to [H.264]. You can set H.265 image quality by setting [Bit Rate Compression Mode] to [VBR] and [Codec] to [H.265].</p>

TP1001804577

Color Video Camera
BRC-AM7

Setting the Audio Codec for Streaming

Set the audio codec using [Stream] – [Audio Stream] in the web menu.

Item	Description
[Setting]	<p>To enable audio streaming, set to on.</p> <p>Note</p> <ul style="list-style-type: none">To select RTMP, always set to on beforehand.
[Codec]	<p>Selects the type of codec to use for streaming audio.</p> <p>[AAC (256kbps)]: Select to prioritize the sound quality.</p> <p>[AAC (128kbps)]: Select to prioritize the data capacity.</p> <p>This setting has no effect on the clip recorded by the unit or the audio signal embedded in the SDI output/HDMI output.</p>

TP1001804578

Color Video Camera
BRC-AM7

Starting/Stopping Streaming

For [RTSP], [SRT-Listener], and [NDI|HX]

The unit waits for a streaming delivery request.

Launch a client application for viewing streaming and access the URL shown in the following table.

Enter the values for the user name and password that are configured on the unit.

Streaming format		URL
[RTSP]	[Video Stream 1]	rtsp://<camera_address>:<Port>/video1
	[Video Stream 2]	rtsp://<camera_address>:<Port>/video2
[SRT-Listener]		srt://<camera_address>:<Port>
[NDI HX]		Refer to the operating instructions for the NDI HX compatible client device.

<camera_address>: IP address of the unit

<Port>: Listener port configured using [Port Number]

Note

- Playback in all applications or devices is not guaranteed.

For [RTMP] and [SRT-Caller]

Press the [Stream now] button on the  (Stream) tab of the live operation screen to start streaming. The button changes to [Stop stream], and the [Stream] icon appears at the top of the camera image panel.

Press the [Stop stream] button during streaming to stop streaming. The button changes back to [Stream now], and the [Stream] icon at the top of the camera image panel disappears.

Note

- Playback in all applications or devices is not guaranteed.

TP1001804579

Color Video Camera
BRC-AM7

Thumbnail Screen

When you press the [Thumbnail] button on the playback operation screen or the THUMBNAIL button on the infrared remote control, clips recorded on the memory card are displayed in the camera image panel. This display on the camera image panel is referred to as the thumbnail screen.

You can select a clip on the thumbnail screen and start playback of that clip.

Pressing the [Thumbnail] button during thumbnail screen display closes the thumbnail screen and returns to the shooting image display.

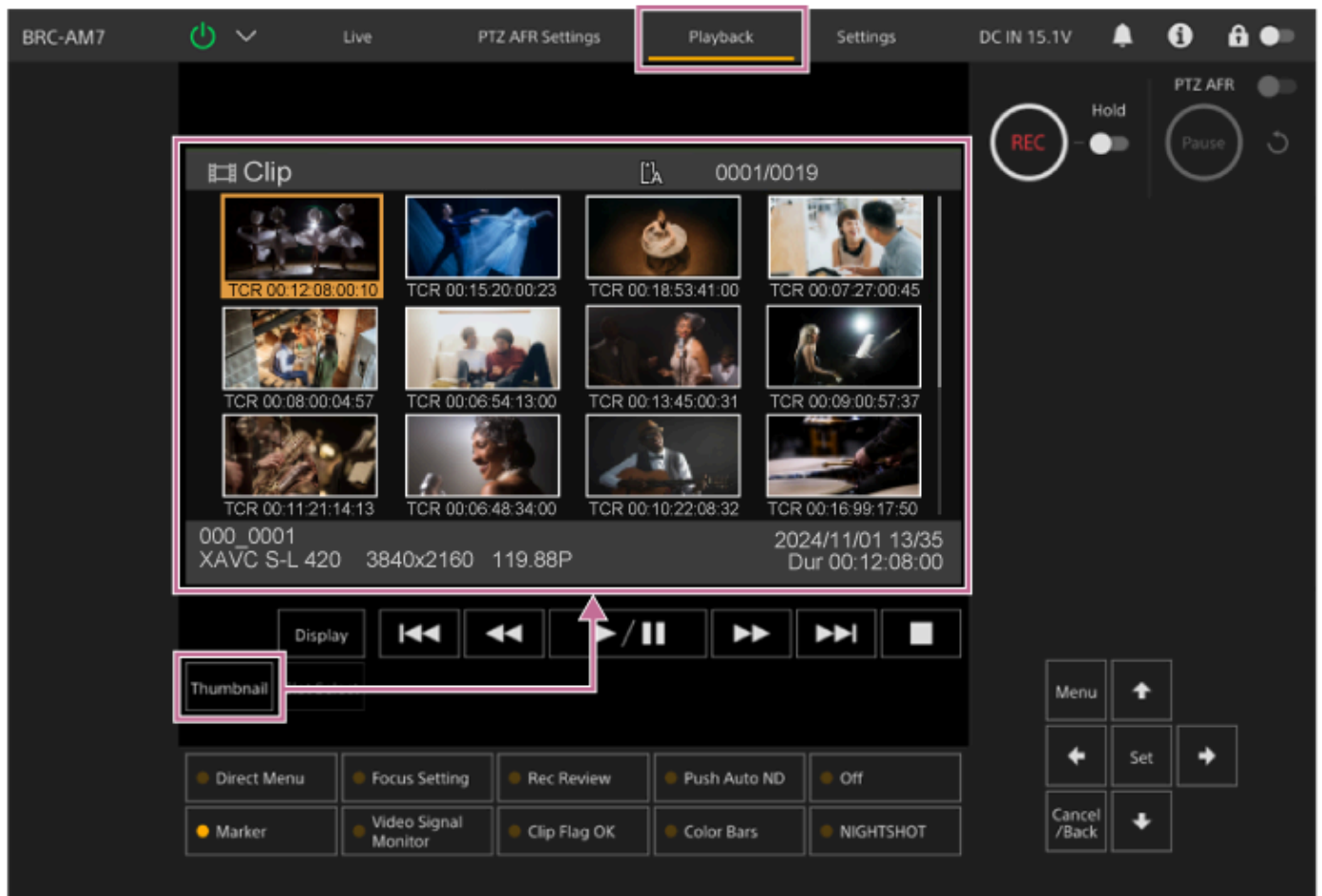

Note

- Only the clips recorded in the currently selected recording format are displayed on the thumbnail screen. If an expected recorded clip is not displayed, check the recording format. Take special note of this fact before formatting (initializing) media.

Screen layout

The thumbnail of a selected clip is displayed with an orange background. Information for the selected clip is displayed at the bottom of the screen.

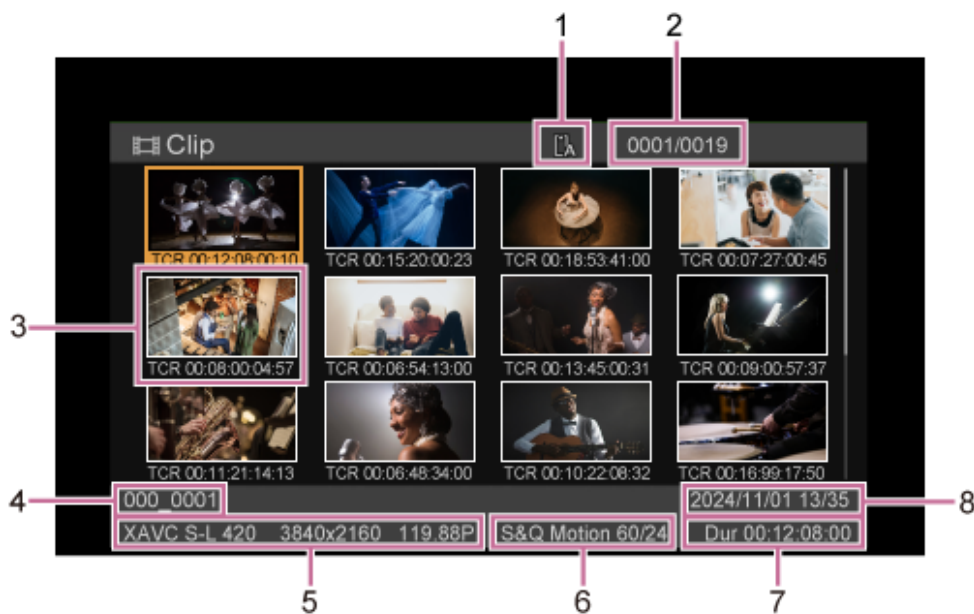

1. Selected memory card

A lock icon appears on the right if the memory card is write-protected.

2. Clip number/total number of clips

3. Thumbnail (index picture)

Displays the index picture of a clip. When a clip is recorded, its first frame is automatically set as the index picture. Clip/frame information is displayed below the thumbnail. You can change the information displayed using [Thumbnail] – [Customize View] – [Thumbnail Caption] in the camera menu.

4. Clip name

Displays the name of the selected clip.

5. Recording format

Displays the file format of the selected clip.

6. Special recording information

Displays the recording mode only if the clip was recorded using a special recording mode. For Slow & Quick Motion clips, the frame rate is displayed on the right.

7. Clip duration

8. Creation date

Color Video Camera
BRC-AM7

Playing Recorded Clips

You can play recorded clips when the unit is in recording standby mode.
This topic describes how to play recorded clips using the GUI control panel.

1 Insert the memory card to play.

2 Press the [Thumbnail] button.

The clip thumbnails appear.

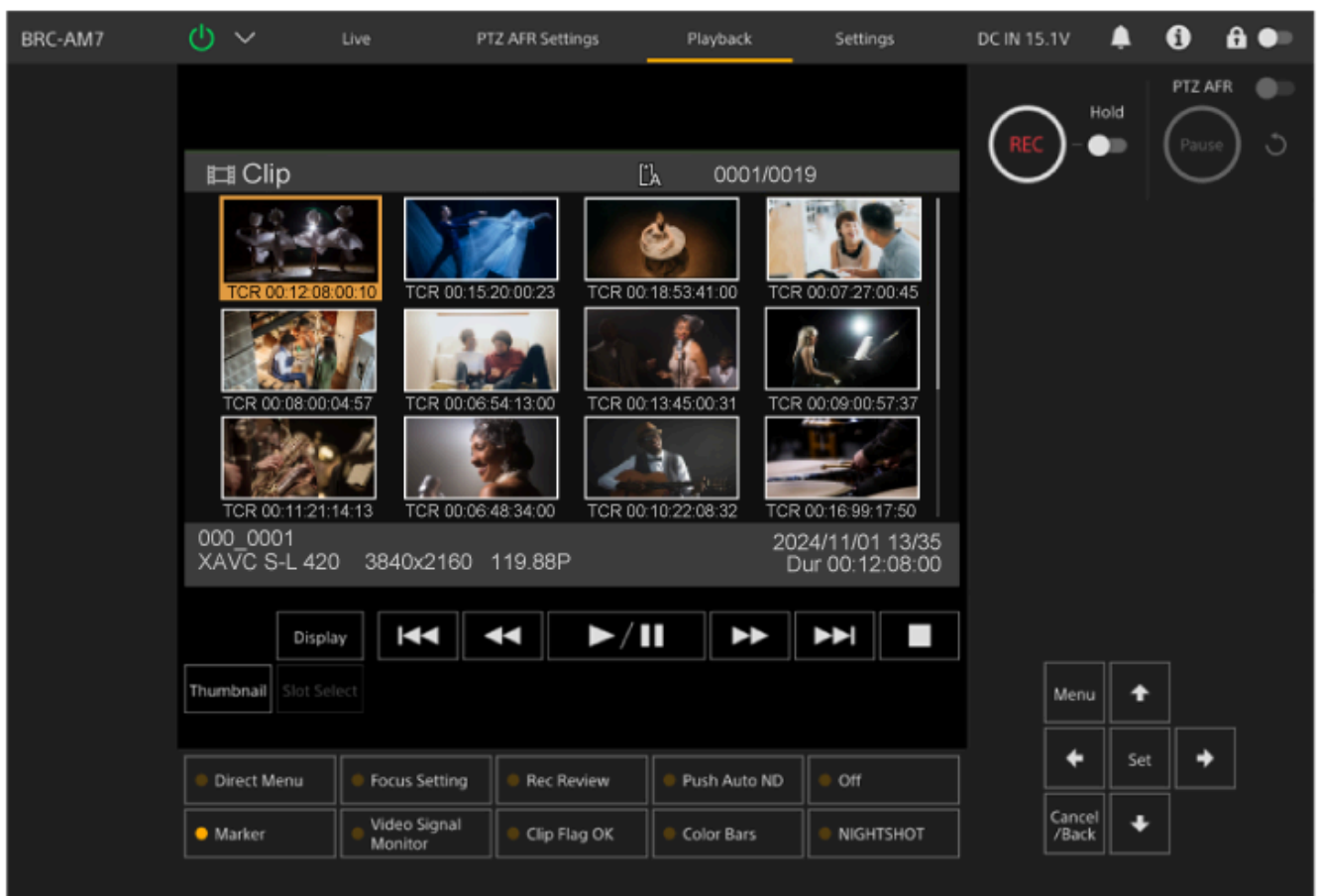

3 Use the arrow buttons in the GUI control panel to move the cursor to the thumbnail for the clip you want to play.

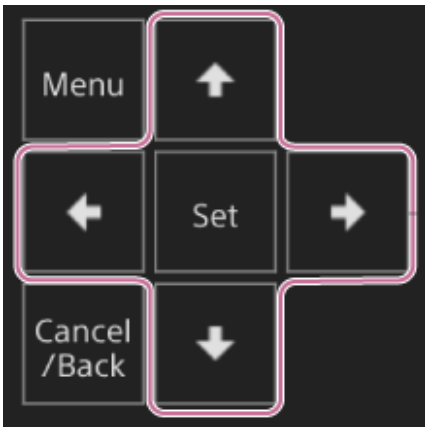

Note

- Clips cannot be selected by touch operation.

4 Press the [Set] button in the GUI control panel.

Playback begins from the start of the selected clip.

5 Operate the playback control panel as required.



Button	Function
(Play/Pause) button	Plays a clip. During playback, pauses the clip.
(Fast Forward) button, (Fast Reverse) button	Plays a clip at high speed. When the button is pressed, the playback speed changes in three steps.
(Previous) button, (Next) button	Jumps to start of clip or the previous/next clip.
(Stop) button	Stops playback and switches to the shooting screen.

Hint

- You can also control operation using the GUI control panel.
 - Play: Press the [Set] button.
 - Playback pause: Press the [Set] button during playback. Press again to return to normal playback.
 - Jump to start of clip/start of next clip: Press the left button/right button.
 - Fast forward/reverse: Press and hold the left button/right button. The playback returns to normal speed when you release the button.
 - Stop playback: Press the [Cancel/Back] button.

Note

- There may be momentary picture breakup or still image display at the boundary between clips. You cannot operate the unit during this period.
- When you select a clip in the thumbnail screen and begin playback, there may be momentary picture distortion at the start of the clip. To view the start of the clip without distortion, pause playback, press the (Previous) button to return to the start of the clip, and start playback again.

Color Video Camera
BRC-AM7

Operations on Recorded Clips

On the thumbnail screen, you can operate the clips or check clip properties using the [Thumbnail] menu in the camera menu. Press the [Menu] button on the playback operation screen to display the camera menu in the camera image panel. You can perform the following operations using the [Thumbnail] menu in the camera menu.

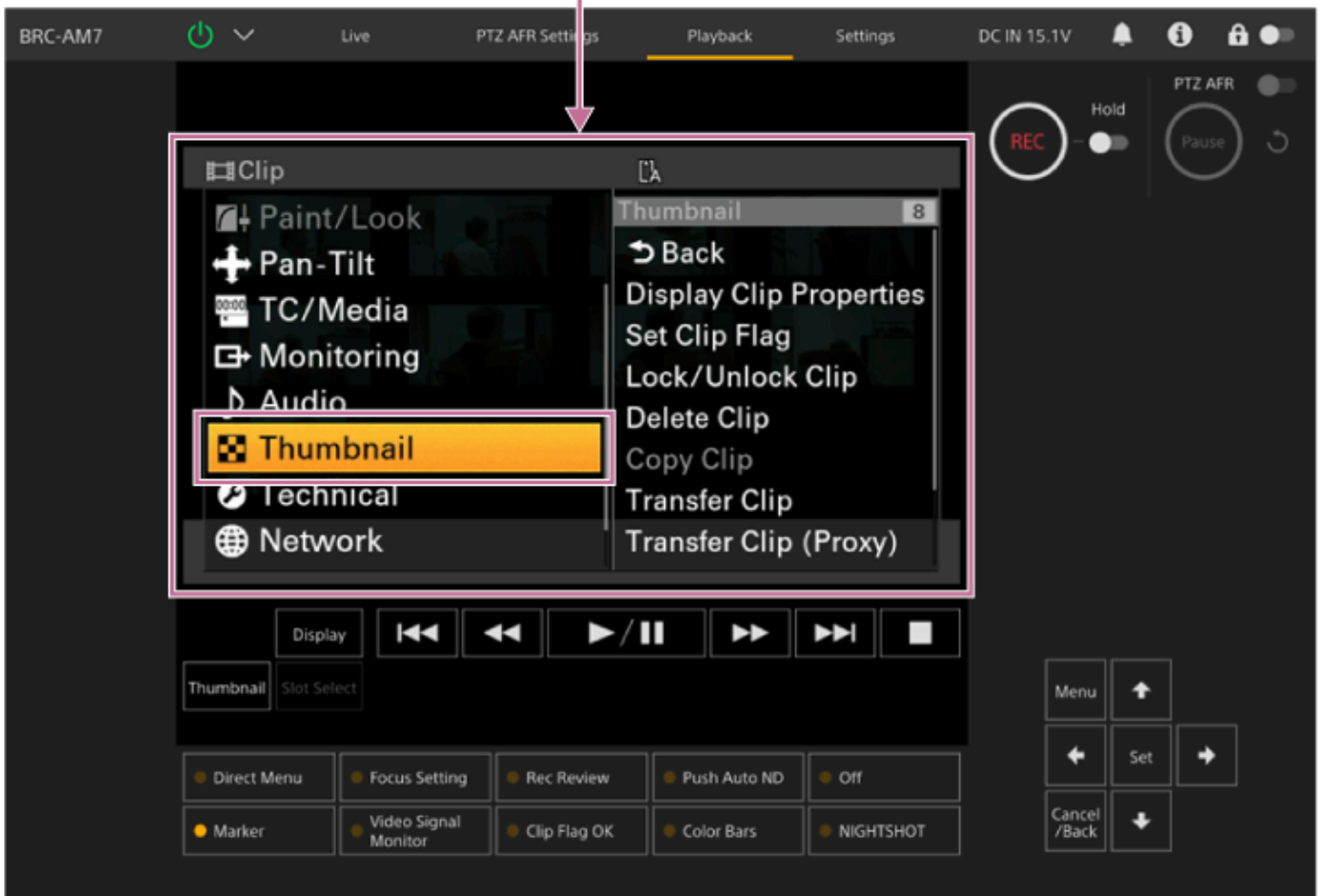
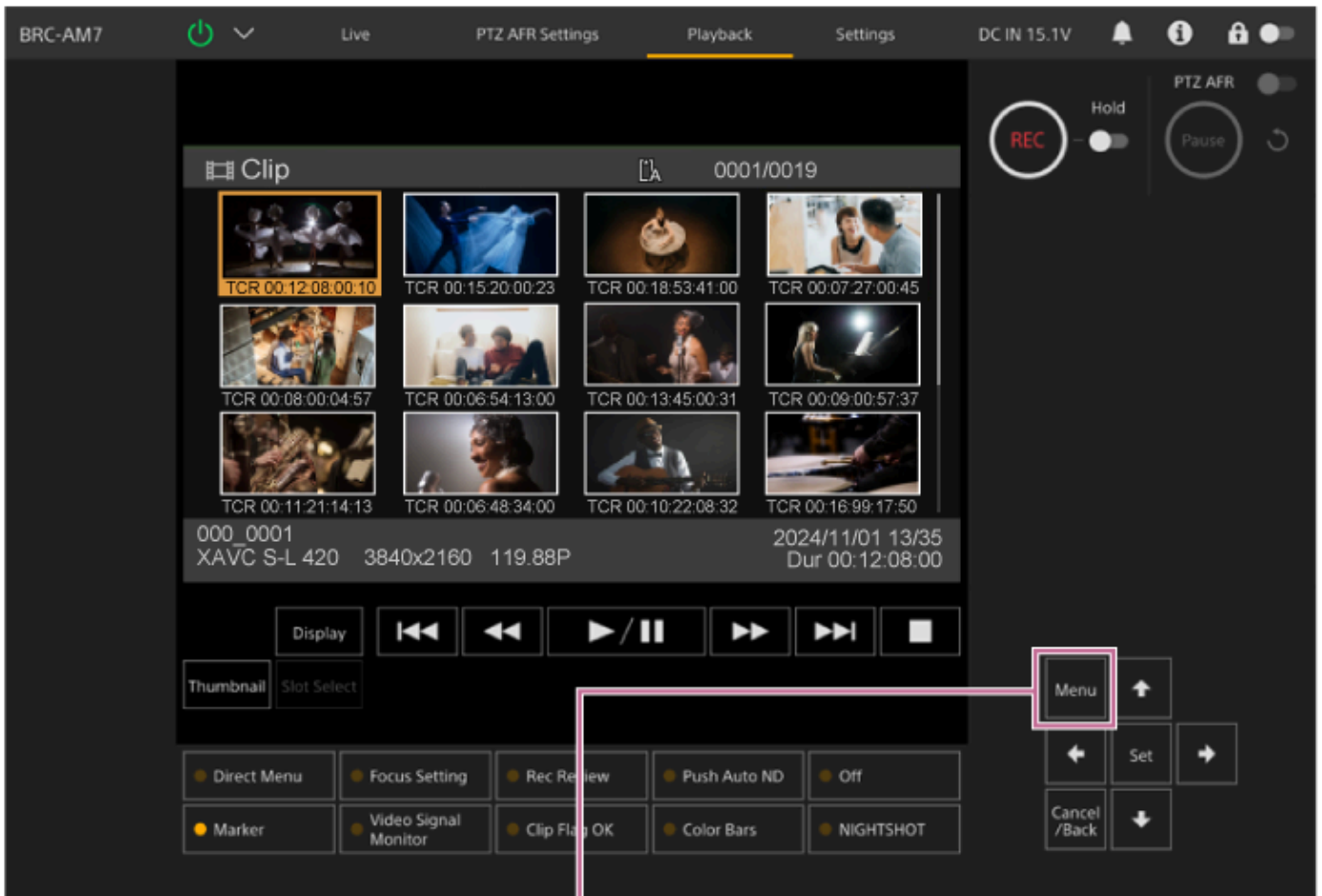

Hint

- You can also press the [Menu] button on the live operation screen to display the camera menu.

Operations using the [Thumbnail] menu in the camera menu

Select a function to operate using the arrow buttons in the GUI control panel and press the [Set] button.
Press the [Cancel/Back] button to return to the previous screen.

Note

- Some items cannot be selected, depending on the state when the menu was displayed.



Menu items for clip operations

The [Thumbnail] menu in the camera menu has the following menu items related to clip operations.

[Display Clip Properties]
[Set Clip Flag]
[Lock/Unlock Clip]
[Delete Clip]
[Copy Clip]
[Transfer Clip]
[Transfer Clip (Proxy)]
[Filter Clips]
[Customize View]

- For details about each menu item, see “Thumbnail Menu.”

To display the clip properties screen

Select [Thumbnail] – [Display Clip Properties] in the camera menu to display the clip properties screen.
Press the  (Previous) button or  (Next) button to jump to the previous/next clip.

To add clip flags

You can add clip flags (OK, NG, or KP marks) to clips to filter the display of clips based on the clip flags.
Select the thumbnail for the clip to which you want to add a clip flag, then select the clip flag using [Thumbnail] – [Set Clip Flag] in the camera menu.

Setting	Added clip flag
[Add OK]	OK
[Add NG]	NG
[Add KEEP]	KP

Hint

- During playback, you can also use an assignable button assigned with the clip flag function to add clip flags.

To display the filtered clip thumbnail screen

Select [Thumbnail] – [Filter Clips] in the camera menu and select a clip flag type to display only those clips that have the specified flag.

To display all clips, select [All].

You can also press the [Display] button to sort the thumbnail display by flags.

To delete clips

You can delete clips from memory cards.

Select [Thumbnail] – [Delete Clip] – [Select Clip] or [All Clips] in the camera menu.

[Select Clip]: Deletes the selected clip. Multiple clip selection is supported.

[All Clips]: Deletes all of the displayed clips.

To copy clips

You can copy clips to another memory card.

Clips are copied to the destination memory card with the same clip names.

Select [Thumbnail] – [Copy Clip] – [Select Clip] or [All Clips] in the camera menu.

[Select Clip]: Copies the selected clip. Multiple clip selection is supported.

[All Clips]: Copies all clips on the same memory card to another memory card.

Note

- If a clip with the same name already exists on the copy destination memory card, the clip will be copied with a name formed by incrementing the number portion of the original clip name.
Example: ABCD0002 → ABCD0003
- A message appears if the remaining capacity of the copy destination memory card is insufficient. Replace the copy destination memory card.
- When copying a memory card on which multiple clips are recorded, it may not be possible to copy all clips even if the capacities of the memory cards are the same, depending on the usage conditions and memory characteristics.

To change the information displayed on the thumbnail screen

You can change the clip/frame information displayed below the thumbnail.

Select [Thumbnail] – [Customize View] – [Thumbnail Caption] in the camera menu and select the information to display.

[Date Time]: Displays the date and time the clip was created and last modified.

[Time Code]: Displays the timecode.

[Duration]: Displays the duration of the clip.

[Sequential Number]: Displays a sequential number on each thumbnail.

TP1001804582

Camera Menu Configuration

When the [Menu] button in the GUI control panel or the MENU button on the infrared remote control is pressed, the camera menu for configuring the various required settings for shooting and playback is displayed in the camera image panel.

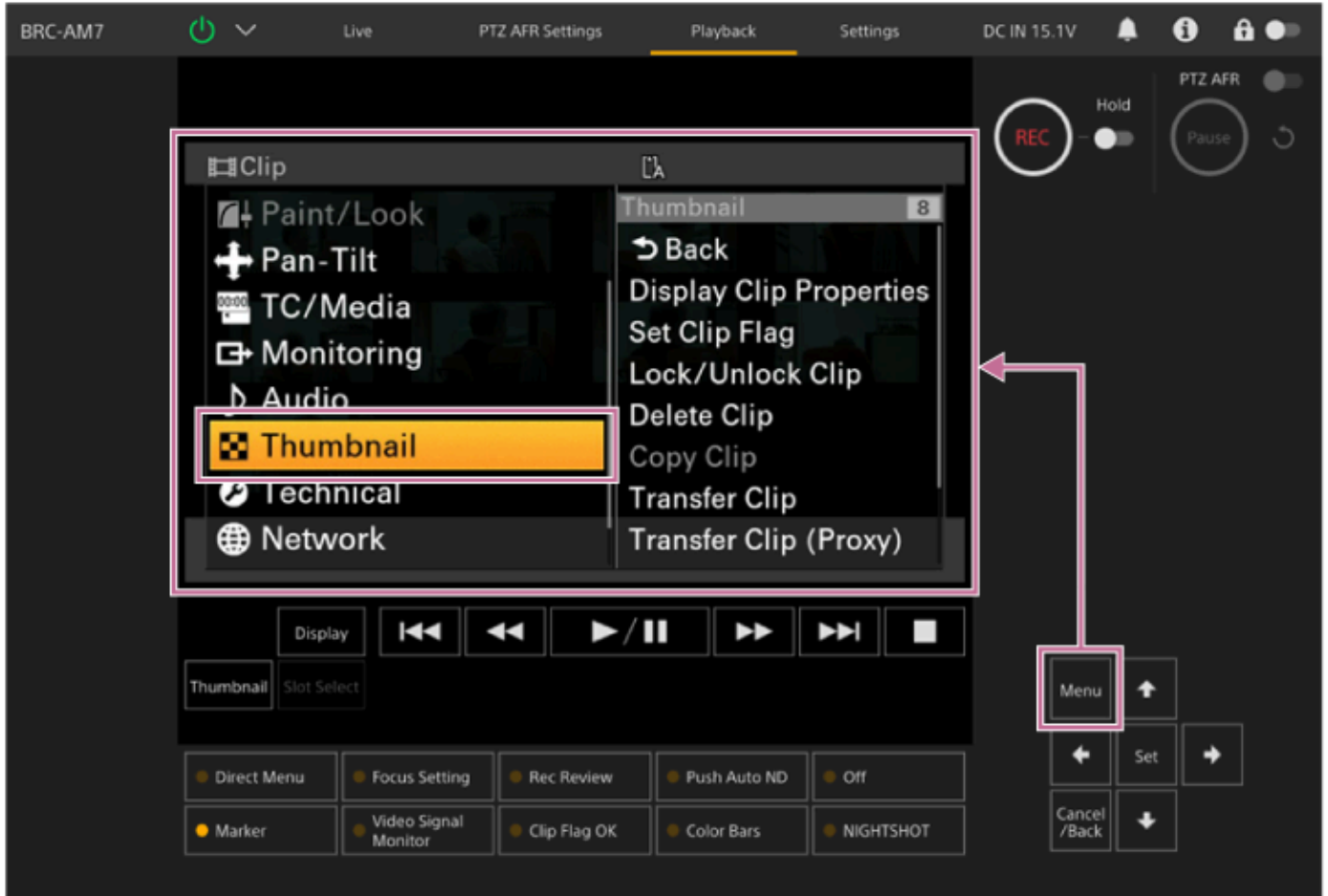

The menu comprises the following menus.

Menu configuration

Item	Description
[User] menu	Contains menu items configured by the user using [Edit User Menu].
[Edit User] menu	Contains menu items for editing the [User] menu.
[Shooting] menu	Contains settings related to shooting.
[Project] menu	Contains basic project settings.
[Paint/Look] menu	Contains settings related to image quality.
[Pan-Tilt] menu	Contains settings related to the pan/tilt.
[TC/Media] menu	Contains settings related to timecodes and recording media.
[Monitoring] menu	Contains settings related to video output and the screen display.

Item	Description
[Audio] menu	Contains settings related to audio.
[Thumbnail] menu	Contains settings related to thumbnail display.
[Technical] menu	Contains settings for technical items.
[Network] menu	Contains settings related to networks.
[Maintenance] menu	Contains devices settings, such as the clock and language.

Camera menu configuration and hierarchy

Level 1	Level 2
[User] (factory settings)	[Base Setting]
	[Focus]
	[S&Q Motion]
	[Simul Rec]
	[Proxy Rec]
	[NIGHTSHOT]
	[Assignable Button]
	[Scene File]
	[Base Look]
	[P/T Acceleration]
	[Clip Name Format]
	[Format Media]
	[Video Signal Monitor]
	[Marker]
	[Zoom]
	[Delete Clip]
	[Copy Clip]
[Transfer Clip]	
[Edit User Menu]	

Level 1	Level 2
[Shooting]	[ISO/Gain]
	[ND Filter]
	[Shutter]
	[Auto Exposure]
	[White]
	[White Setting]
	[Offset White]
	[Focus]
	[S&Q Motion]
	[LUT On/Off]
	[NIGHTSHOT]
	[Noise Suppression]
	[Flicker Reduce]
[Project]	[Base Setting]
	[Rec Format]
	[Flexible ISO Setting]
	[Simul Rec]
	[Proxy Rec]
	[SDI/HDMI Rec Control]
	[Assignable Button]
[Paint/Look]	[Scene File]
	[Base Look]
	[Reset Paint Settings]
	[Black]
	[Knee]
	[Detail]
	[Matrix]
	[Multi Matrix]
[Pan-Tilt]	[P/T Acceleration]

Level 1	Level 2
[TC/Media]	[Timecode]
	[TC Display]
	[Users Bit]
	[HDMI TC Out]
	[Clip Name Format]
	[Update Media]
	[Format Media]
	[Media Life]
[Monitoring]	[Output Format]
	[Display On/Off]
	[Video Signal Monitor]
	[Marker]
[Audio]	[Audio Input]
	[Audio Output]
[Thumbnail]	[Display Clip Properties]
	[Set Clip Flag]
	[Lock/Unlock Clip]
	[Delete Clip]
	[Copy Clip]
	[Transfer Clip]
	[Transfer Clip (Proxy)]
	[Filter Clips]
[Customize View]	
[Technical]	[Color Bars]
	[Genlock]
	[Tally]
	[Rec Review]
	[Zoom]
	[Lens]
	[APR]
[Network]	[Wired LAN]
	[File Transfer]

Level 1	Level 2
[Maintenance]	[Language]
	[Hours Meter]

TP1001804583

5-065-326-11(1) Copyright 2024 Sony Corporation

Color Video Camera
BRC-AM7

Operating the Camera Menu

When the [Menu] button in the GUI control panel or the MENU button on the infrared remote control is pressed, the camera menu for configuring the various required settings for shooting and playback is displayed in the camera image panel. The menu is operated using buttons in the GUI control panel.

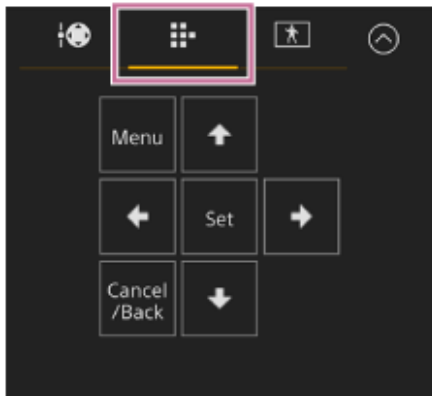

[Menu] button: Press to display the camera menu. Press again while the camera menu is displayed to hide the menu.

Arrow buttons: Press the arrows buttons to move the cursor up/down/left/right in the camera menu to select menu items or settings.

[Set] button: Press to apply the selected item.

[Cancel/Back] button: Press to return to the previous menu. An uncompleted change is canceled.

Note

- Some items cannot be selected, depending on the state when the menu was displayed.

Setting Menu Items

Move the cursor to the item you want to set using the arrow buttons in the GUI control panel and press the [Set] button to apply the setting.

- The menu item selection area displays up to eight lines. If the available options for an item cannot be displayed at the same time, scroll the display by moving the cursor up/down.
- For sub-items with a large settings range (for example, -99 to +99), the settings area is not displayed. The current setting is highlighted to indicate that the value can be changed.
- Selecting [Execute] for a function will execute the corresponding function.
- Selecting an item that requires confirmation before execution will temporarily hide the menu and display a confirmation message. Check the message, and then select whether to execute or cancel the function.

TP1001804584

Color Video Camera
BRC-AM7

Entering a Character String

When you select an item, such as a file name, which requires character entry, the character entry screen appears.

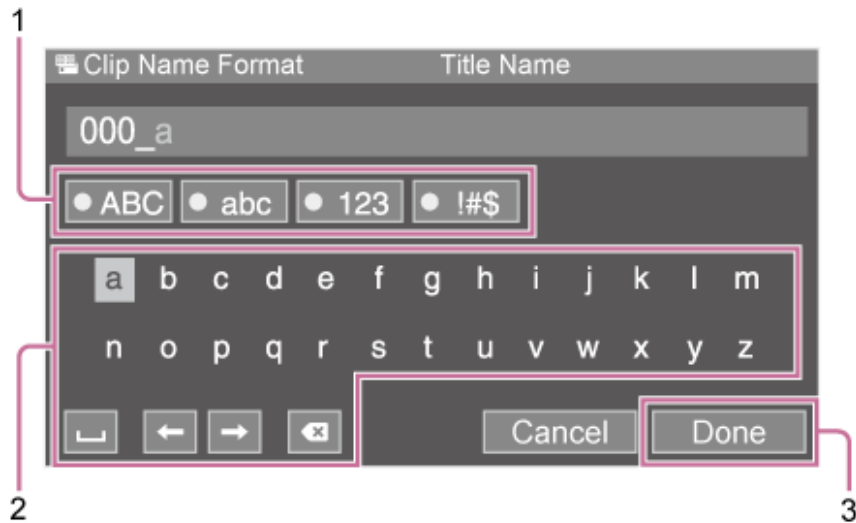

- 1 Press the arrow buttons in the GUI control panel to select the character type and apply the setting.

[ABC]: Uppercase alphabetic characters

[abc]: Lowercase alphabetic characters

[123]: Numeric characters

[!#\$]: Special characters

- 2 Select a character and press the **[Set]** button to apply the setting.

The cursor moves to the next field.

[Space]: Enters a space character at the cursor position.

[←] [→]: Moves the position of the cursor.

[X] (Backspace): Deletes the character on the left of the cursor.

- 3 When finished, press the **[Done]** button to apply the setting.

The character string is confirmed and the character entry screen disappears.

To cancel input, press the **[Cancel]** button.

Color Video Camera
BRC-AM7

[User]

This topic describes the function and settings of each menu item.

Item	Description
[Base Setting]	[Project] – [Base Setting] item
[Focus]	[Shooting] – [Focus] item
[S&Q Motion]	[Shooting] – [S&Q Motion] item
[Simul Rec]	[Shooting] – [Simul Rec] item
[Proxy Rec]	[Project] – [Proxy Rec] item
[NIGHTSHOT]	[Shooting] – [NIGHTSHOT] item
[Assignable Button]	[Project] – [Assignable Button] item
[Scene File]	[Project] – [Scene File] item
[Base Look]	[Paint/Look] – [Base Look] item
[P/T Acceleration]	[Pan-Tilt] – [P/T Acceleration] item
[Clip Name Format]	[TC/Media] – [Clip Name Format] item
[Format Media]	[TC/Media] – [Format Media] item
[Video Signal Monitor]	[Monitoring] – [Video Signal Monitor] item
[Marker]	[Monitoring] – [Marker] item
[Zoom]	[Technical] – [Zoom] item
[Delete Clip]	[Thumbnail] – [Delete Clip] item
[Copy Clip]	[Thumbnail] – [Copy Clip] item
[Transfer Clip]	[Thumbnail] – [Transfer Clip] item
[Edit User Menu]	Displays the [Edit User] menu.

Note

- You can add and remove menu items in the [User] menu using the [Edit User] menu. Up to 20 items can be configured.

[Edit User]

The [Edit User] menu is displayed at the top level when [Edit User Menu] is selected in the [User] menu.

Item	Sub-item setting	Factory default	Description
[Add Item] Add an item to the [User] menu	–	–	Adds a level 2 menu item to the [User] menu.
[Customize Reset] Reset the items in the [User] menu	–	–	Restores the menu items registered in the [User] menu to the factory default.
Level 2 menu item selected during editing	[Delete]	–	Deletes the registered level 2 menu item from the [User] menu.
	[Move]	–	Rearranges the registered menu items within the [User] menu.
	[Edit Sub Item]	–	Edits (register/delete) the registered level 3 menu sub-item in the [User] menu.

TP1001804587

Color Video Camera
BRC-AM7

[ISO/Gain]

Sets gain settings.

Item	Sub-item setting	Factory default	Description
[Mode]	[ISO] / [dB]	[dB]	Selects the gain setting mode.
[ISO/Gain<L>]	<ul style="list-style-type: none">For details about settings, see "ISO/Gain Settings and Default Values."	–	Sets the <L> gain preset value.
[Shockless Gain]	[On] / [Off]	[Off]	Turns the shockless gain function on/off.

Related Topic

- [\[ISO/Gain\] Settings and Default Values](#)

TP1001804588

Color Video Camera
BRC-AM7

[ND Filter]

Sets the preset values for the ND filter.

Item	Sub-item setting	Factory default	Description
[Mode]	[Preset] / [Variable]	[Variable]	Selects the ND filter mode.
[Preset1]	1/4 / 1/8 / 1/16 / 1/32 / 1/64 / 1/128	1/4	Sets the preset 1 value for the ND filter.
[Preset2]	1/4 / 1/8 / 1/16 / 1/32 / 1/64 / 1/128	1/16	Sets the preset 2 value for the ND filter.
[Preset3]	1/4 / 1/8 / 1/16 / 1/32 / 1/64 / 1/128	1/64	Sets the preset 3 value for the ND filter.

TP1001804589

Color Video Camera
BRC-AM7

[Shutter]

Sets electronic shutter operation.
Used for shooting fast-moving subjects clearly.

Item	Sub-item setting	Factory default	Description
[Mode]	[Speed] / [Angle]	[Speed]	Selects the mode for setting the shutter speed in seconds (Speed) or as a shutter angle (Angle).
[Shutter Speed On/Off]	[On] / [Off]	[Off]	Sets whether the exposure time when Speed mode is selected follows the [Shutter Speed] value or is set for full exposure.
[Shutter Speed]	64F to 1/8000 The available settings vary depending on the system frequency of the selected recording format. 119.88: 1/120 / 1/125 / 1/250 / 1/500 / 1/1000 / 1/2000 / 1/4000 / 1/8000 100: 1/100 / 1/120 / 1/125 / 1/250 / 1/500 / 1/1000 / 1/2000 / 1/4000 / 1/8000 : 64F / 32F / 16F / 8F / 7F / 6F / 5F / 4F / 3F / 2F / 1/60 / 1/100 / 1/120 / 1/125 / 1/250 / 1/500 / 1/1000 / 1/2000 / 1/4000 / 1/8000 50: 64F / 32F / 16F / 8F / 7F / 6F / 5F / 4F / 3F / 2F / 1/50 / 1/60 / 1/100 / 1/120 / 1/125 / 1/250 / 1/500 / 1/1000 / 1/2000 / 1/4000 / 1/8000 29.97: 64F / 32F / 16F / 8F / 7F / 6F / 5F / 4F / 3F / 2F / 1/30 / 1/40 / 1/50 / 1/60 / 1/100 / 1/120 / 1/125 / 1/250 / 1/500 / 1/1000 / 1/2000 / 1/4000 / 1/8000 25: 64F / 32F / 16F / 8F / 7F / 6F / 5F / 4F / 3F / 2F / 1/25 / 1/33 / 1/50 / 1/60 / 1/100 / 1/120 / 1/125 / 1/250 / 1/500 / 1/1000 / 1/2000 / 1/4000 / 1/8000 23.98: 64F / 32F / 16F / 8F / 7F / 6F / 5F / 4F / 3F / 2F / 1/24 / 1/32 / 1/48 / 1/50 / 1/60 / 1/96 / 1/100 / 1/120 / 1/125 / 1/250 / 1/500 / 1/1000 / 1/2000 / 1/4000 / 1/8000	119.88: 1/120 100: 1/100 59.94: 1/60 50: 1/50 29.97: 1/30 25: 1/25 23.98: 1/24	Sets the shutter speed when Speed mode is selected.
[Shutter Angle]	64F / 32F / 16F / 8F / 7F / 6F / 5F / 4F / 3F / 2F / 360.0° / 300.0° / 270.0° / 240.0° / 216.0° / 210.0° / 180.0° / 172.8° / 150.0° / 144.0° / 120.0° / 90.0° / 86.4° / 72.0° / 45.0° / 30.0° / 22.5° / 11.25° / 5.6°	180.0°	Sets the shutter angle when [Angle] mode is selected.
[ECS On/Off]	[On] / [Off]	[Off]	Turns [ECS] mode on/off.

Item	Sub-item setting	Factory default	Description
[ECS Frequency]	23.99 to 8000 The available settings vary depending on the system frequency of the selected recording format.	119.88: 120.0 100.0: 100 59.94: 60.00 50: 50.00 29.97: 30.00 23.98: 23.99 25: 25.02	Sets the ECS frequency when Mode is set to ECS.

TP1001804590

[Auto Exposure]

Sets automatic exposure adjustment settings.

Item	Sub-item setting	Factory default	Description
[Level]	+3.0 / +2.75 / +2.5 / +2.25 / +2.0 / +1.75 / +1.5 / +1.25 / +1.0 / +0.75 / +0.5 / +0.25 / ±0 / -0.25 / -0.5 / -0.75 / -1.0 / -1.25 / -1.5 / -1.75 / -2.0 / -2.25 / -2.5 / -2.75 / -3.0	±0	Sets the brightness level for the automatically detected exposure.
[Mode]	[Backlight] / [Standard] / [Spotlight]	[Standard]	Sets the operating mode of auto exposure adjustment. [Backlight] : Backlight mode (mode for reduced darkening of shadows when the subject is backlit) [Standard] : Standard mode [Spotlight] : Spotlight mode (mode for reduced clipped whites when subject is lit by spotlighting)
[Speed]	-99 to +99	±0	Sets the adjustment speed of auto exposure adjustment.
[AGC]	[On] / [Off]	[Off]	Turns auto gain control on/off.
[AGC Limit]	<ul style="list-style-type: none"> For details about settings, see "AGC Limit Settings and Default Values." 	–	Sets the maximum gain of the auto gain control.
[AGC Point]	F2.8 / F4 / F5.6	F2.8	Sets the F-number of the iris where auto gain control operation starts when [AGC] is set to [On].
[Auto Shutter]	[On] / [Off]	[Off]	Turns auto shutter on/off.
[A.SHT Limit]	1/100 / 1/150 / 1/200 / 1/250 / 1/2000	1/2000	Sets the fastest shutter speed of the auto shutter.
[A.SHT Point]	F5.6 / F8 / F11	F8	Sets the F-number of the iris where auto shutter operation starts when [Auto Shutter] is set to [On].
[Clip High light]	[On] / [Off]	[Off]	Turns the function that ignores brightest areas to provide a flatter response at high luminance on/off.
[Detect Window]	1 / 2 / 3 / 4 / 5 / 6 / Custom	1	Sets the light metering range for automatically adjusting the exposure according to the brightness of the subject. (Not available when adjusting exposure manually)

Item	Sub-item setting	Factory default	Description
[Detect Window Indication]	[On] / [Off]	[Off]	Turns the light metering range indication on/off.
[Custom Width]	40 to 999	500	Sets the width of the light metering range.
[Custom Height]	70 to 999	500	Sets the height of the light metering range.
[Custom H Position]	-479 to +479	±0	Sets the horizontal position of the light metering range.
[Custom V Position]	-464 to +464	±0	Sets the vertical position of the light metering range.

Related Topic

- [\[AGC Limit\] Settings and Default Values](#)

TP1001804591

Color Video Camera
BRC-AM7

[White]

Sets white balance settings.

Item	Sub-item setting	Factory default	Description
[Preset White]	2000K to 15000K	3200K	Sets the white balance preset value.
[Color Temp <A>]	2000K to 15000K	3200K	<p>Sets the white balance color temperature saved in memory A.</p> <p>Note</p> <ul style="list-style-type: none"> Since [Color Temp] is clipped at 2000K and 15000K during [R Gain]/[B Gain] operation, it may not be possible to display the correct [Color Temp] value for the R/B gain value.
[Tint<A>]	-99 to +99	±0	<p>Sets the white balance tint value saved in white memory A.</p> <p>Note</p> <ul style="list-style-type: none"> Since [Tint] is clipped at ±99 during [R Gain]/[B Gain] operation, it may not be possible to display the correct [Tint] value for the R/B gain value.
[R Gain <A>]	-99.0 to +99.0	±0.0	Sets the white balance R gain value saved in memory A.
[B Gain <A>]	-99.0 to +99.0	±0.0	Sets the white balance B gain value saved in memory A.

TP1001804592

Color Video Camera
BRC-AM7

[White Setting]

Adjusts white balance settings.

Item	Sub-item setting	Factory default	Description
[Shockless White]	[Off] / 1 / 2 / 3	2	Sets the white balance response speed when switching white balance mode. [Off] : Switches instantaneously. 1 to 3 : Switches more slowly the higher the number.
[ATW Speed]	1 / 2 / 3 / 4 / 5	3	Sets the response speed in ATW mode. The fastest response speed is 1, and the slowest response speed is 5.

TP1001804593

[Offset White]

Sets white balance offset settings.

Item	Sub-item setting	Factory default	Description
[Offset White <A>]	[On] / [Off]	[Off]	Selects whether to add ([On]) or not to add ([Off]) an offset value to the white balance in memory A.
[Offset Color Temp<A>]	-99 to +99	±0	Sets the color temperature offset to be added to the white balance in memory A when [Offset White <A>] is set to [On].
[Offset Tint<A>]	-99 to +99	±0	Sets the [Tint] value offset to be added to the white balance in memory A when [Offset White <A>] is set to [On].
[Offset White<ATW>]	[On] / [Off]	[On]	Selects whether to add ([On]) or not to add ([Off]) an offset value to the ATW white balance.
[Offset Color Temp<ATW>]	-99 to +99	±0	Sets the color temperature offset to be added to the ATW white balance when [Offset White<ATW>] is set to [On].
[Offset Tint<ATW>]	-99 to +99	±0	Sets the [Tint] value offset to be added to the ATW white balance when [Offset White<ATW>] is set to [On].

TP1001804594

Color Video Camera
BRC-AM7

[Focus]

Sets focus settings.

Item	Sub-item setting	Factory default	Description
[AF Transition Speed]	[1(Slow)] / 2 / 3 / 4 / 5 / 6 / [7(Fast)]	5	Sets the speed of the focus drive for when the subject changes during auto focus.
[AF Subj. Shift Sens.]	[1(Locked On)] / 2 / 3 / 4 / [5(Responsive)]	[5(Responsive)]	Sets the sensitivity for changing subject focus during auto focus.
[Focus Area]	[Wide] / [Zone] / [Flexible Spot]	[Wide]	<p>Sets the target area for auto focus and push auto focus (AF).</p> <ul style="list-style-type: none"> See “Adjusting the Focus Automatically (Auto Focus)” and “Setting the Auto Focus Area/Position (Focus Area).” <p>[Wide]: Searches for a subject over a wide angle of the image when focusing. [Zone]: Automatically searches for a focus point within the specified zone. [Flexible Spot]: Focuses on a specified position in the image.</p>
[Subject Recognition AF]	[Human Only AF] / [Human Priority AF] / [Off]	[Human Priority AF]	<p>Enables/disables subject recognition AF.</p> <ul style="list-style-type: none"> See “Detecting and AF Tracking a Person.”
[Touch Function in MF]	[Tracking AF] / [Spot Focus]	[Tracking AF]	Sets the operation when the camera image is touched on the Web App live operation screen in MF mode.
[Multi Selector Function]	[Subject Sel. Cursor] / [Pointer]	[Subject Sel. Cursor]	<p>Sets the method for specifying the auto focus target in response to the arrow buttons in the GUI control panel.</p> <p>[Subject Sel. Cursor]: Selects a subject recognition frame using the arrow buttons in the GUI control panel. [Pointer]: Selects any subject on the screen using the arrow buttons in the GUI control panel as a tracking AF pointer.</p>
[Pointer Color]	[Orange] / [White] / [Yellow] / [Cyan] / [Green] / [Magenta] / [Red] / [Blue]	[Orange]	Sets the color of the pointer used for specifying the focus target.
[Pointer Border]	[On] / [Off]	[On]	Turns the border of the pointer used for specifying the focus target on/off.

Item	Sub-item setting	Factory default	Description
[AF Assist]	[On] / [Off]	[On]	<p>When set to [On], this allows you to temporarily override auto focus and set focus manually.</p> <ul style="list-style-type: none"> ● See “Setting the Auto Focus Target Manually (AF Assist) Using the Web App” and “Focusing Manually During Auto Focus Using the Supplied Infrared Remote Control.”

Related Topic

- [Setting the Auto Focus Area/Position \(Focus Area\)](#)
- [Detecting and AF Tracking a Person](#)
- [Setting the Auto Focus Target Manually \(AF Assist\) Using the Web App](#)
- [Focusing Manually During Auto Focus Using the Supplied Infrared Remote Control](#)

TP1001804595

Color Video Camera
BRC-AM7

[S&Q Motion]

Sets Slow & Quick Motion mode settings (see “Slow & Quick Motion”).

Item	Sub-item setting	Factory default	Description
[Setting]	[On] / [Off]	[Off]	Turns Slow & Quick Motion mode on/off.
[Frame Rate]	1fps to 60fps / 100fps / 120fps / 150fps / 180fps / 200fps / 240fps	—	Sets the frame rate for Slow & Quick Motion shooting. Note <ul style="list-style-type: none"> The available settings vary depending on the selected system frequency, codec, and video format.

Related Topic

- [Slow & Quick Motion](#)

TP1001804596

Color Video Camera
BRC-AM7

[LUT On/Off]

Sets LUT settings.

Item	Sub-item setting	Factory default	Description
[SDI1]	[LUT On] / [LUT Off]	[LUT Off]	Selects whether to apply a LUT to the SDI output video.
[SDI2/HDMI/Stream]	[LUT On] / [LUT Off]	[LUT Off]	Selects whether to apply a monitor LUT to the SDI2, HDMI, and streaming output video.
[Proxy]	[LUT On] / [LUT Off]	[LUT Off]	Selects whether to apply a LUT to the proxy recording video.
[LUT On/Off Button Target]	[SDI1] / [SDI2/HDMI/Stream] / [SDI1 & SDI2/HDMI/Str]	[SDI2/HDMI/Stream]	Sets the target output controlled by an assignable button assigned with LUT on/off operation.

TP1001804597

Color Video Camera
BRC-AM7

[NIGHTSHOT]

Sets night shot settings.

Item	Sub-item setting	Factory default	Description
[Setting]	[On] / [Off]	[Off]	Turns night shot mode on/off. Note <ul style="list-style-type: none">● Cannot be turned on when log shooting mode is enabled.
[Image Color]	[White] / [Green]	[White]	Sets the color of the image when night shot mode is turned on.

TP1001804598

Color Video Camera
BRC-AM7

[Noise Suppression]

Sets noise suppression settings.

Hint

- The [Setting(Custom)] and [Level(Custom)] settings are reflected in the [Target Display] setting.

Item	Sub-item setting	Factory default	Description
[Setting(Custom)]	[On] / [Off]	[On]	Turns the noise suppression function on/off in custom shooting mode. Note <ul style="list-style-type: none"> • This function cannot be configured in log shooting mode.
[Level(Custom)]	[Low] / [Mid] / [High]	[Mid]	Sets the noise suppression level in custom shooting mode. Note <ul style="list-style-type: none"> • This function cannot be configured in log shooting mode.
[Setting(Flexible ISO)]	[On] / [Off]	[Off]	Turns the noise suppression function on/off in log shooting mode. Note <ul style="list-style-type: none"> • This function cannot be configured in log shooting mode.
[Level(Flexible ISO)]	[Low] / [Mid] / [High]	[Mid]	Sets the noise suppression level in log shooting mode. Note <ul style="list-style-type: none"> • This function cannot be configured in log shooting mode.

TP1001804599

Color Video Camera
BRC-AM7

[Flicker Reduce]

Sets flicker correction settings.

Item	Sub-item setting	Factory default	Description
[Mode]	[Auto] / [On] / [Off]	[Off]	Sets the flicker correction mode.
[Frequency]	[50Hz] / [60Hz]	[60Hz]	Sets the frequency of the power source supplying the lighting that is causing the flicker.

TP1001804600

Color Video Camera
BRC-AM7

[Base Setting]

Sets base settings.

Item	Sub-item setting	Factory default	Description
[Shooting Mode]	[Custom] / [Flexible ISO]	[Custom]	Sets the shooting mode. <ul style="list-style-type: none">• See “Setting the shooting mode” in “Configuring Basic Operation.”
[Target Display]	[SDR(BT.709)] / [HDR(HLG)]	[SDR(BT.709)]	Sets the video standard for recording/output in custom shooting mode.

Related Topic

- [Configuring Basic Operation](#)

TP1001804601

Color Video Camera
BRC-AM7

[Rec Format]

Sets recording format settings.

Item	Sub-item setting	Factory default	Description
[Frequency]	119.88 / 100 / 59.94 / 50 / 29.97 / 25 / 23.98	59.94	Selects the system frequency.
[Codec]	[XAVC HS-L 422] / [XAVC HS-L 420] / [XAVC S-L 422] / [XAVC S-L 420] / [XAVC S-I]	[XAVC S-L 420]	Sets the clip recording/playback codec.
[Video Format]	For details about settings, see the following topic. [Video Format] / [Quality] / [Bit Rate] Settings	–	Sets the image size and scan method.
[Quality]		–	Sets the recording bit rate.
[Bit Rate]		–	Displays the recording bit rate.

Related Topic

- [\[Video Format\] / \[Quality\] / \[Bit Rate\] Settings](#)

TP1001804602

Color Video Camera
BRC-AM7

[Flexible ISO Setting]

Sets Log shooting mode settings (see “Setting the shooting mode” in “Configuring Basic Operation”).

Item	Sub-item setting	Factory default	Description
[Color Gamut]	[S-Gamut3/SLog3] / [S-Gamut3.Cine/SLog3]	[S-Gamut3.Cine/SLog3]	Sets the color gamut for log shooting mode ([Flexible ISO]).
[Embed LUT File]	[On] / [Off]	[On]	Turns 3D LUT file (CUBE file) metadata recording on/off.

Related Topic

- [Configuring Basic Operation](#)

TP1001804603

Color Video Camera
BRC-AM7

[Simul Rec]

Sets 2-slot simultaneous recording mode settings (see “Recording to Memory Cards A and B Simultaneously (2-slot Simul Rec)”).

Item	Sub-item setting	Factory default	Description
[Setting]	[On] / [Off]	[Off]	Turns 2-slot simultaneous recording mode on/off.
[Rec Button Set]	[Rec Button]: [<Slot A>] [<Slot B>] [2nd Rec Button]: [<Slot A>] [<Slot B>] / [Rec Button]: [<Slot A>] [2nd Rec Button]: [<Slot B>] / [Rec Button]: [<Slot B>] [2nd Rec Button]: [<Slot A>]	[Rec Button]: [<Slot A>] [<Slot B>] [2nd Rec Button]: [<Slot A>] [<Slot B>]	Assigns the record buttons used to control each recording media.

TP1001804604

Color Video Camera
BRC-AM7

[Proxy Rec]

Sets proxy recording mode settings (see “Proxy Recording”).

Item	Sub-item setting	Factory default	Description
[Setting]	[On] / [Off]	[Off]	Turns proxy recording mode on/off.
[Proxy Format]	[HEVC 1920 (16M)] / [HEVC 1920 (9M)] / [AVC 1280 (6M)]	[AVC 1280 (6M)]	Sets the picture size for the proxy file.
[Audio Channel]	[CH1/CH2] / [CH3/CH4]	[CH1/CH2]	Selects the audio channel to record to proxy data.

TP1001804605

[SDI/HDMI Rec Control]

Sets SDI/HDMI recording control settings.

Item	Sub-item setting	Factory default	Description
[Setting]	[Off] / [SDI/HDMI Remote I/F] / [Parallel Rec]	[Off]	<p>Sets recording start/stop control of an external connected device via the SDI/HDMI output signal.</p> <p>[Off]: Do not use remote control.</p> <p>[SDI/HDMI Remote I/F]: Record stop/start control of an external connected device, when there is no media inserted in the unit. Not synchronized with frame accuracy to media in the unit.</p> <p>[Parallel Rec]: Record stop/start control of an external connected device, when media is inserted in the unit. Synchronized with frame accuracy to media in the unit.</p> <p>Note</p> <ul style="list-style-type: none"> For control using the HDMI output signal, set [TC/Media] – [HDMI TC Out] – [Setting] to [On] in the camera menu.

TP1001804606

Color Video Camera
BRC-AM7

[Assignable Button]

Sets function assignments to assignable buttons (<1> to <10>).

The following functions can be assigned.

Item	Description
[Off]	No function assignment.
[ISO/Gain]	Switches the gain value.
[AGC]	Turns the AGC function on/off.
[Push AGC]	Enables the AGC function while the button is pressed.
[ND Filter]	In variable mode: Adjusts the ND filter transmittance. Press and hold to switch between [Clear]/[Manual]/[Auto]. In preset mode: Press and hold to switch presets.
[ND Filter Position]	Switches ND filters.
[Auto ND Filter]	Turns the auto ND filter function on/off instantly.
[Push Auto ND]	Turns the push auto ND filter function on/off.
[Auto Iris]	Turns the iris function on/off.
[Push Auto Iris]	Enables the auto iris function while the button is pressed.
[Shutter]	Displays/exits the [Shutter] direct menu.
[Auto Shutter]	Turns the auto shutter function on/off.
[AE Level/Mode]	Adjusts the AE level. Press and hold to switch the AE mode.
[Backlight]	Switches between Backlight and Standard.
[Spotlight]	Switches between Spotlight and Standard.
[Preset White Select]	Switches the white balance preset mode value.
[ATW]	Turns the ATW function on/off.
[ATW Hold]	Pauses ATW function operation.
[AF Speed/Sens.]	Switches the AF transition speed setting and AF subject shift sensitivity setting.
[Focus Setting]	Sets the focus area.
[Subject Recognition AF]	Switches the subject recognition auto focus operation.
[Push AF/Push MF]	Activates auto focus while the button is pressed in manual focus mode. Activates manual focus while the button is pressed in auto focus mode.
[Focus Hold]	In AF focus mode, focus is fixed while the button is pressed.
[S&Q Motion]	Turns the Slow & Quick Motion function on/off. Sets the shooting frame rate if pressed and held.

Item	Description
[LUT On/Off]	Turns the LUT on/off. The switching target is set using [Shooting] – [LUT On/Off] – [LUT On/Off Button Target].
[NIGHTSHOT]	Turns night shot mode on/off.
[Rec]	Starts/stops recording.
[Rec Review]	Turns the recording review function on/off.
[Shot Mark1]	Adds shot mark1 to the currently recording or playing clip
[Shot Mark2]	Adds shot mark2 to the currently recording or playing clip
[Clip Flag OK]	Executes Add OK. Press twice to execute Delete Clip Flag.
[Clip Flag NG]	Executes Add NG. Press twice to execute Delete Clip Flag.
[Clip Flag Keep]	Executes Add KEEP. Press twice to execute Delete Clip Flag.
[Slot Select]	Switches between memory slot (A) and (B).
[Color Bars]	Turns color bars on/off.
[DURATION/TC/U-BIT]	Switches between Time Code, Users Bit, and Duration.
[Display]	Turns the screen display on/off.
[Lens Info]	Switches the depth-of-field indicator.
[Video Signal Monitor]	Switches the video signal monitor (such as a waveform monitor).
[Marker]	Turns the marker function on/off.
[Thumbnail]	Displays/exits the thumbnail screen.
[Auto Upload (Proxy)]	Turns proxy file auto transfer on/off.
[Direct Menu]	Displays/exits the direct menu.
[User Menu]	Displays/exits the User menu.

TP1001804607

Color Video Camera
BRC-AM7

[Scene File]

Sets settings related to scene files (see “Look Overview”).

Item	Sub-item setting	Factory default	Description
[Recall]	–	–	Loads a scene file stored in internal memory and applies the settings as the current image quality settings.
[Store]	–	–	Saves the current image quality state as a scene file in internal memory.
[Delete]	–	–	Deletes a scene file stored in internal memory.
[Preset Recall]	When [Shooting Mode] is set to [Custom] and [Target Display] is set to [SDR(BT.709)]: [S-Cinetone] / [ITU709] / [709tone] When [Shooting Mode] is set to [Custom] and [Target Display] is set to [HDR(HLG)]: [HLG Live] / [HLG Mild] / [HLG Natural]	–	Applies preset image quality settings (non-rewritable) as the current image quality settings.

Related Topic

- [Look Overview](#)

TP1001804608

[Base Look]

Sets settings related to the base look.

Item	Sub-item setting	Factory default	Description
[Select]	When [Shooting Mode] is set to [Custom] and [Target Display] is set to [SDR(BT.709)]: [S-Cinetone] / [ITU709] / [709tone] / User1 to User16 When [Shooting Mode] is set to [Custom] and [Target Display] is set to [HDR(HLG)]: [HLG Live] / [HLG Mild] / [HLG Natural] / User1 to User16 In log shooting mode: [s709] / [709(800%)] / [S-Log3] / User1 to User16	When [Shooting Mode] is set to [Custom] and [Target Display] is set to [SDR(BT.709)]: [ITU709] When [Shooting Mode] is set to [Custom] and [Target Display] is set to [HDR(HLG)]: [HLG Mild] In log shooting mode: [s709]	Selects a base look.
[Delete]	–	–	Deletes the selected base look.
[Delete All]	–	–	Deletes all base looks.
[Input]	[S-Gamut3/SLog3] / [S-Gamut3.Cine/SLog3]	[S-Gamut3.Cine/SLog3]	Sets the input gamut for the base look selected using [Select].
[Output]	[BT.709] / [HLG]	[BT.709]	Sets the output color gamut for the base look selected using [Select].
[AE Level Offset]	0EV / 1/3EV / 2/3EV / 1EV / 4/3EV / 5/3EV / 2EV	0EV	Sets the exposure reference value for the base look selected using [Select].

TP1001804609

Color Video Camera
BRC-AM7

[Reset Paint Settings]

Resets the [Paint/Look] menu settings, excluding the base look.

Item	Sub-item setting	Factory default	Description
[Reset without Base Look]	[Execute] / [Cancel]	—	Resets the [Paint/Look] menu settings, excluding the base look. [Execute]: Execute function.

TP1001804610

Color Video Camera
BRC-AM7

[Black]

Sets black settings.

Item	Sub-item setting	Factory default	Description
[Master Black]	-99.0 to +99.0	±0.0	Sets the master black level.
[R Black]	-99.0 to +99.0	±0.0	Sets the R black level.
[B Black]	-99.0 to +99.0	±0.0	Sets the B black level.

TP1001804611

Color Video Camera
BRC-AM7

[Knee]

Sets knee correction settings.

Item	Sub-item setting	Factory default	Description
[Setting]	[On] / [Off]	When [Target Display] is set to [SDR(BT.709)]: [Off] When [Target Display] is set to [HDR(HLG)]: [Off]	Turns the knee correction function on/off. Note <ul style="list-style-type: none"> Enabled only when [Base Look] – [Select] is set to [ITU709], [709tone], [HLG Live], [HLG Mild], or [HLG Natural].
[Auto Knee]	[On] / [Off]	When [Target Display] is set to [SDR(BT.709)]: [On] When [Target Display] is set to [HDR(HLG)]: [Off]	Turns the auto knee function on/off. Note <ul style="list-style-type: none"> Enabled only when [Base Look] – [Select] is set to [ITU709] or [709tone].
[Point]	75% to 109%	90%	Sets the knee point.
[Slope]	-99 to +99	±0	Sets the knee slope.

TP1001804613

Color Video Camera
BRC-AM7

[Detail]

Sets detail adjustment settings.

Item	Sub-item setting	Factory default	Description
[Setting]	[On] / [Off]	[On]	Turns the detail function on/off.
[Level]	-7 to +7	±0	Sets the detail level.
[Manual Setting]	[On] / [Off] / ---	[Off]	Turns the detail manual adjustment function on/off.
[H/V Ratio]	-2 to +2	±0	Sets the balance between horizontal (H) detail and vertical (V) detail for detail manual adjustment.
[B/W Balance]	[Type1] / [Type2] / [Type3] / [Type4] / [Type5]	[Type3]	Sets the balance between black (B) detail for low-luminance areas and white (W) detail for high-luminance areas for detail manual adjustment.
[Limit]	0 to 7	1	Sets the limit level of the detail for detail manual adjustment.
[Crispening]	0 to 7	0	Sets the crispening level for detail manual adjustment.
[High Light Detail]	0 to 4	0	Sets the detail level of high-luminance areas for detail manual adjustment.

TP1001804614

Color Video Camera
BRC-AM7

[Matrix]

Sets matrix correction settings.

Item	Sub-item setting	Factory default	Description
[User Matrix]	[On] / [Off]	[Off]	Turns the user matrix correction function on/off.
[User Matrix Level]	-99 to +99	±0	Adjusts the color saturation of the entire image.
[User Matrix Phase]	-99 to +99	±0	Adjusts the color tone (phase) of the entire image.
[User Matrix R-G]	-99 to +99	±0	Sets a user-defined R-G user matrix.
[User Matrix R-B]	-99 to +99	±0	Sets a user-defined R-B user matrix.
[User Matrix G-R]	-99 to +99	±0	Sets a user-defined G-R user matrix.
[User Matrix G-B]	-99 to +99	±0	Sets a user-defined G-B user matrix.
[User Matrix B-R]	-99 to +99	±0	Sets a user-defined B-R user matrix.
[User Matrix B-G]	-99 to +99	±0	Sets a user-defined B-G user matrix.

TP1001804615

[Multi Matrix]

Sets multi matrix correction settings.

Item	Sub-item setting	Factory default	Description
[Setting]	[On] / [Off]	[Off]	Turns the multi matrix correction function on/off.
[Area Indication]	[On] / [Off]	[Off]	<p>Turns on/off the display function that identifies the target area corresponding to the target color axis for adjustment selected in [Axis]. The parts of the captured image outside the target area are displayed in monotone.</p> <p>Hint</p> <ul style="list-style-type: none"> On the multi matrix correction setup screen, you can turn [Area Indication] on/off using the [Display] button. <p>Note</p> <ul style="list-style-type: none"> [Area Indication] is applied to all video outputs. Be aware of this fact when using a video output signal as the main signal.
[Area Indication Control]	[Menu Only] / [Menu & RCP]	[Menu Only]	Sets the interface that can control [Area Indication].
[Reset]	[Execute] / [Cancel]	–	Resets the hue and saturation of each axis color to the default values.
[Axis]	B / B+ / MG- / MG / MG+ / R / R+ / YL- / YL / YL+ / G- / G / G+ / CY / CY+ / B-	B	Selects the axis.
[Hue]	-99 to +99	±0	Sets the hue of the color used for multi matrix correction.
[Saturation]	-99 to +99	±0	Sets the saturation of the color used for multi matrix correction.

Color Video Camera
BRC-AM7

[P/T Acceleration]

Sets settings related to acceleration for pan/tilt operations.

Item	Sub-item setting	Factory default	Description
[Ramp Curve]	1 to 9	8	Selects the acceleration/deceleration for pan/tilt operations. The larger the number, the higher the acceleration.

TP1001804617

Color Video Camera
BRC-AM7

[Timecode]

Sets timecode settings.

Item	Sub-item setting	Factory default	Description
[Mode]	[Preset] / [Regen] / [Clock]	[Preset]	Sets the timecode running mode. [Preset]: Starts running from a preset value. [Regen]: Starts running from the timecode of the end of the previous clip. [Clock]: Uses the internal clock as the timecode.
[Run]	[Rec Run] / [Free Run]	[Rec Run]	[Rec Run]: Runs only when recording. [Free Run]: Always running, regardless of recording operation.
[Setting]	–	–	Sets the timecode to an arbitrary value. [Set]: Set the value.
[Reset]	[Execute] / [Cancel]	–	Resets the timecode to 00:00:00:00. [Execute]: Execute function.
[TC Format]	[DF] / [NDF]	[DF]	Sets the timecode format. [DF]: Drop Frame [NDF]: Non-Drop Frame

TP1001804618

Color Video Camera
BRC-AM7

[TC Display]

Sets time data display settings.

Item	Sub-item setting	Factory default	Description
[Display Select]	[Timecode] / [Users Bit] / [Duration]	[Timecode]	Switches the time data display.

TP1001804619

Color Video Camera
BRC-AM7

[Users Bit]

Sets settings related to user bits.

Item	Sub-item setting	Factory default	Description
[Mode]	[Fix] / [Time]	[Fix]	Sets the user bit mode. [Fix]: Uses an arbitrary fixed value in user bits. [Time]: Uses the current hour, minute, and second in user bits.
[Setting]	–	–	Sets the user bits to an arbitrary value.

TP1001804620

Color Video Camera
BRC-AM7

[HDMI TC Out]

Sets settings related to timecode output when using HDMI.

Item	Sub-item setting	Factory default	Description
[Setting]	[On] / [Off]	[Off]	Sets whether to output the timecode to devices for other purposes, using HDMI.

TP1001804621

Color Video Camera
BRC-AM7

[Clip Name Format]

Sets settings related to clip naming and deletion.

Item	Sub-item setting	Factory default	Description
[Clip Number]	[Series] / [Reset]	[Series]	<p>Sets the numbering method of clip numbers.</p> <p>[Series]: A method of generating numbers starting from a series number counter stored in the unit. However, if the largest number among the clips on a memory card is greater than the series number counter, the numbering will start from that number.</p> <p>[Reset]: A method of numbering starting from the highest number among the clips on a memory card.</p>
[Series Counter Reset]	[Execute] / [Cancel]	—	<p>Resets the series number counter stored in the unit.</p> <p>Hint</p> <ul style="list-style-type: none"> Each time a clip is recorded, the series number counter is updated with the number of that clip.
[Title Name Settings]	Enter an arbitrary character	C	Sets the title part of the clip name.

Related Topic

- [Entering a Character String](#)

TP1001804622

Color Video Camera
BRC-AM7

[Update Media]

Updates the management file on memory cards (see “Restoring Memory Cards”).

Item	Sub-item setting	Factory default	Description
[Media(A)]	[Execute] / [Cancel]	–	Updates the management file on the memory card in slot A. [Execute]: Execute function.
[Media(B)]	[Execute] / [Cancel]	–	Updates the management file on the memory card in slot B. [Execute]: Execute function.

Related Topic

- [Restoring Memory Cards](#)

TP1001804623

Color Video Camera
BRC-AM7

[Format Media]

Formats (initializes) memory cards (see “Formatting (Initializing) Memory Cards”).

Item	Sub-item setting	Factory default	Description
[Media(A)]	[Full Format] / [Quick Format] / [Cancel]	–	Formats the memory card in slot A.
[Media(B)]	[Full Format] / [Quick Format] / [Cancel]	–	Formats the memory card in slot B.

Related Topic

- [Formatting \(Initializing\) Memory Cards](#)

TP1001804624

Color Video Camera
BRC-AM7

[Media Life]

Displays the remaining life of the memory cards.

Item	Sub-item setting	Factory default	Description
[Media(A)]	–	–	Displays the remaining life of the memory card in slot A.
[Media(B)]	–	–	Displays the remaining life of the memory card in slot B.

Note

- Requires memory cards that support remaining media life display.

TP1001804625

Color Video Camera
BRC-AM7

[Output Format]

Sets output format settings.

Item	Sub-item setting	Factory default	Description
[SDI1]	For details about settings, see "Output Formats and Limitations."	–	Sets the SDI and HDMI output resolution.
[SDI2]		–	
[HDMI]		–	

Related Topic

- [Output Formats and Limitations](#)

TP1001804626

Color Video Camera
BRC-AM7

[Display On/Off]

Sets display item settings.

To show a display item, select On. To hide a display item, select Off.

Item	Sub-item setting	Factory default
[File Transfer Status]	[On] / [Off]	[On]
[Rec/Play Status]	[On] / [Off]	[On]
[Tally]	[On] / [Off]	[On]
[Focus Mode]	[On] / [Off]	[On]
[Focus Position]	[On] / [Off]	[On]
[Focus Area Indicator]	[On] / [Off]	[On]
[Subject Recognition Frame]	[On] / [Off]	[On]
[Tracking AF Pointer]	[On] / [Off]	[On]
[Lens Info]	[On] / [Off]	[Off]
[Rec Format]	[On] / [Off]	[On]
[Frame Rate]	[On] / [Off]	[On]
[Zoom Position]	[On] / [Off]	[On]
[Base Look/Rec Look]	[On] / [Off]	[On]
[SDI/HDMI Rec Control]	[On] / [Off]	[On]
[Monitoring Look]	[On] / [Off]	[On]
[Proxy Status]	[On] / [Off]	[On]
[Media Status]	[On] / [Off]	[On]
[Clip Name]	[On] / [Off]	[On]
[White Balance]	[On] / [Off]	[On]
[Scene File]	[On] / [Off]	[On]
[Auto Exposure Mode]	[On] / [Off]	[On]
[Auto Exposure Level]	[On] / [Off]	[On]
[Timecode]	[On] / [Off]	[On]
[ND Filter]	[On] / [Off]	[On]
[Iris]	[On] / [Off]	[On]
[ISO/Gain]	[On] / [Off]	[On]

Item	Sub-item setting	Factory default
[Shutter]	[On] / [Off]	[On]
[Level Gauge]	[On] / [Off]	[On]
[Audio Level Meter]	[On] / [Off]	[On]
[Video Level Warning]	[On] / [Off]	[On]
[NIGHTSHOT]	[On] / [Off]	[On]
[Clip Number]	[On] / [Off]	[On]
[Notice Message]	[On] / [Off]	[On]

TP1001804627

5-065-326-11(1) Copyright 2024 Sony Corporation

Color Video Camera
BRC-AM7

[Video Signal Monitor]

Sets video signal monitor settings.

Item	Sub-item setting	Factory default	Description
[Setting]	[Off] / [Waveform] / [Vector] / [Histogram]	[Off]	Sets the type of video signal monitor.
[Level Marker 1]	0% to 109%	70%	Sets the level of luminance level marker 1.
[Level Marker 2]	0% to 109%	100%	Sets the level of luminance level marker 2.

TP1001804628

Color Video Camera
BRC-AM7

[Marker]

Sets marker display settings.

Item	Sub-item setting	Factory default	Description
[Setting]	[On] / [Off]	[On]	Turns the display of all markers on/off.
[Color]	[White] / [Yellow] / [Cyan] / [Green] / [Magenta] / [Red] / [Blue]	[White]	Selects the marker signal color.
[Center Marker]	1 / 2 / 3 / 4 / [Off]	[Off]	Selects the center marker.
[Safety Zone]	[On] / [Off]	[Off]	Turns the safety zone marker on/off.
[Safety Area]	80% / 90% / 92.5% / 95%	90%	Selects the size of the safety zone marker (as a percentage of total screen size).
[Aspect Marker]	[Line] / [Mask] / [Off]	[Off]	Selects the type of aspect marker.
[Aspect Mask]	0 to 15	12	Sets the level of the video signal outside the marker.
[Aspect Safety Zone]	[On] / [Off]	[Off]	Turns the aspect safety zone marker on/off.
[Aspect Safety Area]	80% / 90% / 92.5% / 95%	90%	Selects the size of the aspect safety zone marker (as a percentage of total screen size).
[Aspect Select]	1:1 / 4:3 / 13:9 / 14:9 / 15:9 / 17:9 / 1.66:1 / 1.85:1 / 2.35:1 / 2.39:1 / [Custom]	2.39:1	Sets the mode when displaying the aspect marker.
[Custom Aspect Ratio]	Enter an arbitrary value.	01.00:01.00	Sets the aspect ratio to an arbitrary value. Note ● The setting is applied when [Aspect Select] is set to [Custom].
[Guide Frame]	[On] / [Off]	[Off]	Turns the guide frame display on/off.
[100% Marker]	[On] / [Off]	[Off]	Turns the 100% marker display on/off.
[User Box]	[On] / [Off]	[Off]	Turns the user box marker display on/off.
[User Box Width]	3 to 479	240	Sets the user box marker width (distance from the center to the left and right edges).
[User Box Height]	3 to 269	135	Sets the user box marker height (distance from the center to the top and bottom edges).

Item	Sub-item setting	Factory default	Description
[User Box H Position]	-476 to +476	0	Sets the horizontal position of the center of the user box marker.
[User Box V Position]	-266 to +266	0	Sets the vertical position of the center of the user box marker.

TP1001804629

5-065-326-11(1) Copyright 2024 Sony Corporation

Color Video Camera
BRC-AM7

[Audio Input]

Sets audio input settings.

Item	Sub-item setting	Factory default	Description
[AUDIO IN 1 Select]	[MIC] / [LINE]	[MIC]	Selects the type of device connected to the AUDIO IN 1 connector.
[AUDIO IN 2 Select]	[MIC] / [LINE]	[MIC]	Selects the type of device connected to the AUDIO IN 2 connector.
[AUDIO IN 1 MIC +48V]	[On] / [Off]	[Off]	Displays the enable/disable state of the +48 V phantom power supply of the device connected to the AUDIO IN 1 connector.
[AUDIO IN 2 MIC +48V]	[On] / [Off]	[Off]	Displays the enable/disable state of the +48 V phantom power supply of the device connected to the AUDIO IN 2 connector.
[CH1 Input Select]	[AUDIO IN 1] / [MIC (L)]	[AUDIO IN 1]	Switches the input source for recording on channel 1.
[CH2 Input Select]	[AUDIO IN 1] / [AUDIO IN 2] / [MIC (R)]	[AUDIO IN 2]	Switches the input source for recording on channel 2.
[CH3 Input Select]	[Off] / [AUDIO IN 1] / [MIC (L)]	[AUDIO IN 1]	Switches the input source for recording on channel 3.
[CH4 Input Select]	[Off] / [AUDIO IN 1] / [AUDIO IN 2] / [MIC (R)]	[AUDIO IN 2]	Switches the input source for recording on channel 4.
[AUDIO IN CH1 MIC Ref.]	-80dB / -70dB / -60dB / -50dB / -40dB / -30dB	-50dB	Sets the reference recording level for XLR microphone input from AUDIO IN CH1.
[AUDIO IN CH2 MIC Ref.]	-80dB / -70dB / -60dB / -50dB / -40dB / -30dB	-50dB	Sets the reference recording level for XLR microphone input from AUDIO IN CH2.
[Line Input Reference]	+4dB / 0dB / -3dB / EBUL	+4dB	Selects the reference input level when [AUDIO IN 1 Select] or [AUDIO IN 2 Select] is set to [LINE].
[Reference Level]	-20dB / -18dB / -16dB / -12dB / [EBUL]	-20dB	Selects the recording level of the 1 kHz reference tone signal.
[CH1 Wind Filter]	[On] / [Off]	[Off]	Enables/disables the wind reduction filter for channel 1 recording.
[CH2 Wind Filter]	[On] / [Off]	[Off]	Enables/disables the wind reduction filter for channel 2 recording.
[CH3 Wind Filter]	[On] / [Off]	[Off]	Enables/disables the wind reduction filter for channel 3 recording.

Item	Sub-item setting	Factory default	Description
[CH4 Wind Filter]	[On] / [Off]	[Off]	Enables/disables the wind reduction filter for channel 4 recording.
[CH1 Level Control]	[Auto] / [Manual]	[Auto]	Selects audio input level automatic adjustment or manual adjustment for recording channel 1.
[CH2 Level Control]	[Auto] / [Manual]	[Auto]	Selects audio input level automatic adjustment or manual adjustment for recording channel 2.
[CH3 Level Control]	[Auto] / [Manual]	[Auto]	Selects audio input level automatic adjustment or manual adjustment for recording channel 3.
[CH4 Level Control]	[Auto] / [Manual]	[Auto]	Selects audio input level automatic adjustment or manual adjustment for recording channel 4.
[CH1 Input Level]	0 to 99	49	Sets the input level for recording channel 1.
[CH2 Input Level]	0 to 99	49	Sets the input level for recording channel 2.
[CH3 Input Level]	0 to 99	49	Sets the input level for recording channel 3.
[CH4 Input Level]	0 to 99	49	Sets the input level for recording channel 4.
[Master Input Level]	0 to 99	99	Sets the master audio input level.
[Limiter Mode]	[Off] / -6dB / -9dB / -12dB / -15dB / -17dB	[Off]	Selects the limiter characteristic for large input signals when adjusting the audio input level manually.
[CH1&2 AGC Mode]	[Mono] / [Stereo]	[Stereo]	Sets the auto level adjustment mode for recording channel 1 and channel 2. When set to Stereo, the AGC is linked between channels.
[CH3&4 AGC Mode]	[Mono] / [Stereo]	[Stereo]	Sets the auto level adjustment mode for recording channel 3 and channel 4. When set to Stereo, the AGC is linked between channels.
[AGC Spec]	-6dB / -9dB / -12dB / -15dB / -17dB	-6dB	Selects the AGC characteristic.
[1kHz Tone on Color Bars]	[On] / [Off]	[Off]	Turns the 1 kHz reference tone signal on/off when displaying color bars. <div style="border: 1px solid #ccc; background-color: #f9f9f9; padding: 5px;"> <p>Note</p> <ul style="list-style-type: none"> When set to [On], the 1 kHz reference tone signal is set for recording on channel 3 and channel 4, even if [CH3 Input Select] and [CH4 Input Select] are set to [Off]. </div>

TP1001804630

Color Video Camera
BRC-AM7

[Audio Output]

Sets audio output settings.

Item	Sub-item setting	Factory default	Description
[SDI2/HDMI/Strm Out CH]	[CH1/CH2] / [CH3/CH4]	[CH1/CH2]	Sets the combination of audio channels for the SDI2/HDMI/streaming output.

TP1001804631

Color Video Camera
BRC-AM7

[Display Clip Properties]

Displays the clip properties screen.

Item	Sub-item setting	Factory default	Description
[Display Clip Properties]	–	–	Displays the clip properties screen.

TP1001804632

Color Video Camera
BRC-AM7

[Set Clip Flag]

Sets clip flag settings.

Item	Sub-item setting	Factory default	Description
[Add OK]	–	–	Adds an OK flag.
[Add NG]	–	–	Adds an NG flag.
[Add KEEP]	–	–	Adds a KEEP flag.
[Delete Clip Flag]	–	–	Deletes all flags.

TP1001804633

Color Video Camera
BRC-AM7

[Lock/Unlock Clip]

Sets clip protection settings.

Item	Sub-item setting	Factory default	Description
[Select Clip]	–	–	Selects and locks/unlocks a clip.
[Lock All Clips]	–	–	Locks all clips.
[Unlock All Clips]	–	–	Unlocks all clips.

TP1001804634

Color Video Camera
BRC-AM7

[Delete Clip]

Deletes clips.

Item	Sub-item setting	Factory default	Description
[Select Clip]	–	–	Deletes the selected clip.
[All Clips]	–	–	Deletes all clips.

TP1001804635

Color Video Camera
BRC-AM7

[Copy Clip]

Copies clips.

Item	Sub-item setting	Factory default	Description
[Select Clip]	–	–	Copies selected clips.
[All Clips]	–	–	Copies all clips within the media.

TP1001804636

Color Video Camera
BRC-AM7

[Transfer Clip]

Transfers clips.

Item	Sub-item setting	Factory default	Description
[Select Clip]	–	–	Transfers selected clips.
[All Clips]	–	–	Transfers all clips. Note <ul style="list-style-type: none">● Up to 200 transfer jobs can be registered.

TP1001804637

Color Video Camera
BRC-AM7

[Transfer Clip (Proxy)]

Transfers proxy clips.

Item	Sub-item setting	Factory default	Description
[Select Clip]	–	–	Transfers proxy clips corresponding to the selected clips.
[All Clips]	–	–	Transfers proxy clips corresponding to all the clips. Note <ul style="list-style-type: none">● Up to 200 transfer jobs can be registered.

TP1001804638

Color Video Camera
BRC-AM7

[Filter Clips]

Sets settings of clips to display.

Item	Sub-item setting	Factory default	Description
[OK]	–	–	Display only clips that have an OK flag.
[NG]	–	–	Display only clips that have an NG flag.
[KEEP]	–	–	Display only clips that have a KEEP flag.
[None]	–	–	Display only clips that have no flag.
[All]	–	–	Displays all clips, regardless of whether there are any flags.

TP1001804639

Color Video Camera
BRC-AM7

[Customize View]

Switches the thumbnail screen view.

Item	Sub-item setting	Factory default	Description
[Thumbnail Caption]	[Date Time] / [Time Code] / [Duration] / [Sequential Number]	[Time Code]	Switches the information displayed below thumbnails.

TP1001804640

Color Video Camera
BRC-AM7

[Color Bars]

Sets color bar settings.

Item	Sub-item setting	Factory default	Description
[Setting]	[On] / [Off]	[Off]	Turns color bars on/off.
[Type]	[ARIB] / 100% / 75% / [SMPTE]	[ARIB]	Selects the color bar type.

TP1001804641

Color Video Camera
BRC-AM7

[Genlock]

Configures the genlock status display (see “Synchronizing the Phase of the Video Signal (Genlock)”).

Item	Sub-item setting	Factory default	Description
[Reference]	[Internal] / [External(HD)] / [External(SD)]	–	Displays the type of genlock reference signal.

Related Topic

- [Synchronizing the Phase of the Video Signal \(Genlock\)](#)

TP1001804642

Color Video Camera
BRC-AM7

[Tally]

Sets recording/tally lamp settings (see “Connecting a Tally Signal”).

Item	Sub-item setting	Factory default	Description
[Tally Lamp Brightness]	[High] / [Low] / [Off]	[High]	Sets the brightness of the recording/tally lamp.
[G Tally Lamp]	[Enable] / [Disable]	[Enable]	Enables/disables the G (green) tally lamp.
[Y Tally Lamp]	[Enable] / [Disable]	[Enable]	Enables/disables the Y (yellow) tally lamp.
[Tally Control]	[External] / [Internal] / [PTZ AFR]	[Internal]	Selects the target for accepting the recording/tally lamp control information of the unit. [External]: Tally control from outside the camera (tally lamp). [Internal]: Control via camera recording operation (recording lamp). [PTZ AFR]: Control via the PTZ AFR operating status.

Related Topic

- [Connecting a Tally Signal](#)

TP1001804643

Color Video Camera
BRC-AM7

[Rec Review]

Sets recording review settings (see “Reviewing the Recording (Rec Review)”).

Item	Sub-item setting	Factory default	Description
[Setting]	[3s] / [10s] / [Clip]	[3s]	Sets the time for playback of clips just recorded for recording review.

Related Topic

- [Reviewing the Recording \(Rec Review\)](#)

TP1001804644

Color Video Camera
BRC-AM7

[Zoom]

Sets settings related to the zoom (see “Adjusting the Zoom Using the Web App”).

Item	Sub-item setting	Factory default	Description
[Zoom Type]	[Optical Zoom Only] / [On(Clear Image Zoom)]	[Optical Zoom Only]	Sets the type of zoom.

Related Topic

- [Adjusting the Zoom Using the Web App](#)

TP1001804645

Color Video Camera
BRC-AM7

[Lens]

Sets settings related to lenses.

Item	Sub-item setting	Factory default	Description
[Distance Display]	[Meter] / [Feet]	[Meter]	Sets the display units for lens information and focus position.
[Zoom Position Display]	[Number] / [Bar]	[Number]	Sets the display format for the zoom position.

TP1001804646

Color Video Camera
BRC-AM7

[APR]

Executes APR.

Item	Sub-item setting	Factory default	Description
[APR]	[Execute] / [Cancel]	–	Runs APR (Automatic Pixel Restoration) for image sensor auto adjustment. [Execute]: Execute function.

TP1001804647

Color Video Camera
BRC-AM7

[Wired LAN]

Displays information related to wired LAN connections.

Item	Sub-item setting	Factory default	Description
[DHCP]	[On] / [Off]	–	Displays the DHCP enable/disable state.
[IP Address]	–	–	Displays the IP address of the unit.
[Subnet Mask]	–	–	Displays the subnet mask of the unit.
[Gateway]	–	–	Displays the IP address of the default gateway.
[DNS Auto]	[On] / [Off]	–	Displays the DNS auto acquisition enable/disable state.
[HTTP Port]	–	–	Displays the HTTP access port.

TP1001804648

Color Video Camera
BRC-AM7

[File Transfer]

Sets settings related to file transfers (see “About File Transfer”).

Item	Sub-item setting	Factory default	Description
[Auto Upload (Proxy)]	[On] / [Off]	[Off]	Turns proxy file auto upload on/off.
[Default Upload Server]	Server Settings1 to 3 > Display Name	–	Selects the upload server for files. The server selected here becomes the auto upload destination for proxy files, and the upload destination for files from the thumbnail screen. Displays the [Display Name] settings configured in [Server Settings1 to 3].
[Clear Completed Jobs]	[Execute] / [Cancel]	–	Clears completed transfer jobs from the list. [Execute]: Execute function.
[Clear All Jobs]	[Execute] / [Cancel]	–	Clears all transfer jobs from the list. [Execute]: Execute function.
[View Job List]	–	–	Displays the transfer job list.

Related Topic

- [About File Transfer](#)

TP1001804649

Color Video Camera
BRC-AM7

[Language]

Sets the display language.

Item	Sub-item setting	Factory default	Description
[Select]	–	–	Sets the display language. [Set]: Set the value.

TP1001804650

Color Video Camera
BRC-AM7

[Hours Meter]

Displays the accumulated running time.

Item	Sub-item setting	Factory default	Description
[Hours(System)]	–	–	Displays the accumulated hours of use (cannot be reset).
[Hours(Reset)]	–	–	Displays the accumulated hours of use (can be reset).
[Reset]	[Execute] / [Cancel]	–	Resets the accumulated running time to 0. [Execute]: Execute function.

TP1001804652

[ISO/Gain] Settings and Default Values

The range of [ISO/Gain] settings and default values vary depending on the [Mode], [Target Display], and [Base Look] – [Select] settings.

When [Mode] is set to [ISO]

Custom shooting mode

✓: Supported

×: Not supported

[Target Display]	[SDR(BT.709)]	[HDR(HLG)]	[SDR(BT.709)] and [HDR(HLG)]
[Base Look] – [Select]	Preset base look	Preset base look	User base look
ISO 250	✓ ([ISO/Gain<L>] default value)	×	×
ISO 320	✓	×	×
ISO 400	✓	×	×
ISO 500	✓	×	×
ISO 640	✓	×	×
ISO 800	✓	×	×
ISO 1000	✓	×	×
ISO 1250	✓	×	×
ISO 1600	✓	✓ ([ISO/Gain<L>] default value)	✓ ([ISO/Gain<L>] default value)
ISO 2000	✓	✓	✓
ISO 2500	✓	✓	✓
ISO 3200	✓	✓	✓
ISO 4000	✓	✓	✓
ISO 5000	✓	✓	✓
ISO 6400	✓	✓	✓
ISO 8000	✓	✓	✓
ISO 12800	✓	✓	✓
ISO 16000	✓	×	×

Log shooting mode

- ✓ : Supported
- ✗ : Not supported

Settings range	
ISO 1600	✓ ([ISO/Gain<L>] default value)
ISO 2000	✓
ISO 2500	✓
ISO 3200	✓
ISO 4000	✓
ISO 5000	✓
ISO 6400	✓
ISO 8000	✓
ISO 10000	✓
ISO 12800	✓

When [Mode] is set to [dB]

- ✓ : Supported
- ✗ : Not supported

[Target Display]	[SDR(BT.709)]	[HDR(HLG)]	[SDR(BT.709)] and [HDR(HLG)]
[Base Look] – [Select]	Preset base look	Preset base look	User base look
-3dB	✓	✓	✓
-2dB	✓	✓	✓
-1dB	✓	✓	✓
0dB	✓ ([ISO/Gain<L>] default value)	✓ ([ISO/Gain<L>] default value)	✓ ([ISO/Gain<L>] default value)
1dB	✓	✓	✓
2dB	✓	✓	✓
3dB	✓	✓	✓
4dB	✓	✓	✓
5dB	✓	✓	✓
6dB	✓	✓	✓
7dB	✓	✓	✓
8dB	✓	✓	✓
9dB	✓	✓	✓
10dB	✓	✓	✓

[Target Display]	[SDR(BT.709)]	[HDR(HLG)]	[SDR(BT.709)] and [HDR(HLG)]
[Base Look] – [Select]	Preset base look	Preset base look	User base look
11dB	✓	✓	✓
12dB	✓	✓	✓
13dB	✓	✓	✓
14dB	✓	✓	✓
15dB	✓	✓	✓
16dB	✓	✓	✓
17dB	✓	✓	✓
18dB	✓	✓	✓
19dB	✓	×	×
20dB	✓	×	×
21dB	✓	×	×
22dB	✓	×	×
23dB	✓	×	×
24dB	✓	×	×
25dB	✓	×	×
26dB	✓	×	×
27dB	✓	×	×
28dB	✓	×	×
29dB	✓	×	×
30dB	✓	×	×
31dB	✓	×	×
32dB	✓	×	×
33dB	✓	×	×
34dB	✓	×	×
35dB	✓	×	×
36dB	✓	×	×

Note

- The minimum value is 0dB when shooting HFR (high frame rate) in Slow & Quick Motion mode or when the system frequency is 119.88P/100P.

Color Video Camera
BRC-AM7

[AGC Limit] Settings and Default Values

The range of [AGC Limit] settings and default values vary depending on the [Mode], [Target Display], and [Base Look] – [Select] settings.

When [Mode] is set to [ISO]

Custom shooting mode

✓ : Supported

× : Not supported

[Target Display]	[SDR(BT.709)]	[HDR(HLG)]	[SDR(BT.709)] and [HDR(HLG)]
[Base Look] – [Select]	Preset base look	Preset base look	User base look
ISO 320	✓	×	×
ISO 400	✓	×	×
ISO 500	✓	×	×
ISO 640	✓	×	×
ISO 800	✓	×	×
ISO 1000	✓	×	×
ISO 1250	✓	×	×
ISO 1600	✓	×	×
ISO 2000	✓	✓	✓
ISO 2500	✓	✓	✓
ISO 3200	✓	✓	✓
ISO 4000	✓	✓	✓
ISO 5000	✓	✓	✓
ISO 6400	✓	✓ (default value)	✓ (default value)
ISO 8000	✓ (default value)	✓	✓
ISO 12800	✓	✓	✓
ISO 16000	✓	×	×

Log shooting mode

✓ : Supported

× : Not supported

Settings range	
ISO 2000	✓

Settings range	
ISO 2500	✓
ISO 3200	✓
ISO 4000	✓
ISO 5000	✓
ISO 6400	✓ (default value)
ISO 8000	✓
ISO 10000	✓
ISO 12800	✓

When [Mode] is set to [dB]

✓ : Supported

× : Not supported

[Target Display]	[SDR(BT.709)]	[HDR(HLG)]	[SDR(BT.709)] and [HDR(HLG)]
[Base Look] – [Select]	Preset base look	Preset base look	User base look
3dB	✓	✓	✓
6dB	✓	✓	✓
9dB	✓	✓	✓
12dB	✓	✓	✓
15dB	✓	✓	✓
18dB	✓	✓ (default value)	✓ (default value)
21dB	✓	×	×
24dB	✓	×	×
27dB	✓	×	×
30dB	✓ (default value)	×	×
33dB	✓	×	×
36dB	✓	×	×

TP1001804654

[Video Format] / [Quality] / [Bit Rate] Settings

The range of [Video Format]/[Quality]/[Bit Rate] settings vary depending on the [Frequency]/[Codec] settings.

[Frequency]	[Codec]	[Video Format]	[Quality]		
			[High]	[Mid]	[Low]
119.88	XAVC HS-L 422	3840×2160P	280	280	280
	XAVC HS-L 420	3840×2160P	200	200	200
	XAVC S-L 422	3840×2160P	280	280	280
	XAVC S-L 420	3840×2160P	200	200	200
		1920×1080P	100	60	60
100	XAVC HS-L 422	3840×2160P	280	280	280
	XAVC HS-L 420	3840×2160P	200	200	200
	XAVC S-L 422	3840×2160P	280	280	280
	XAVC S-L 420	3840×2160P	200	200	200
		1920×1080P	100	60	60
59.94	XAVC HS-L 422	3840×2160P	200	100	100
	XAVC HS-L 420	3840×2160P	150	75	45
	XAVC S-L 422	3840×2160P	200	200	200
		1920×1080P	50	50	50
	XAVC S-L 420	3840×2160P	150	150	150
		1920×1080P	50	25	25
	XAVC S-I	3840×2160P	600	600	600
		1920×1080P	222	222	222

[Frequency]	[Codec]	[Video Format]	[Quality]		
			[High]	[Mid]	[Low]
50	XAVC HS-L 422	3840×2160P	200	100	100
	XAVC HS-L 420	3840×2160P	150	75	45
	XAVC S-L 422	3840×2160P	200	200	200
		1920×1080P	50	50	50
	XAVC S-L 420	3840×2160P	150	150	150
		1920×1080P	50	25	25
	XAVC S-I	3840×2160P	500	500	500
		1920×1080P	185	185	185
29.97	XAVC S-L 422	3840×2160P	140	140	140
		1920×1080P	50	50	50
	XAVC S-L 420	3840×2160P	100	60	60
		1920×1080P	50	16	16
	XAVC S-I	3840×2160P	300	300	300
		1920×1080P	111	111	111
25	XAVC S-L 422	3840×2160P	140	140	140
		1920×1080P	50	50	50
	XAVC S-L 420	3840×2160P	100	60	60
		1920×1080P	50	16	16
	XAVC S-I	3840×2160P	250	250	250
		1920×1080P	93	93	93
23.98	XAVC HS-L 422	3840×2160P	100	50	50
	XAVC HS-L 420	3840×2160P	100	50	30
	XAVC S-L 422	3840×2160P	100	100	100
		1920×1080P	50	50	50
	XAVC S-L 420	3840×2160P	100	60	60
		1920×1080P	50	50	50
	XAVC S-I	3840×2160P	240	240	240
		1920×1080P	89	89	89

Image Quality Settings Saved for Each Shooting Mode

The current status of configuration items related to image quality are saved for each of the following shooting modes. When you change the shooting mode, the corresponding settings that are saved for the target shooting mode are applied.

- [Custom] mode – [SDR(BT.709)]
- [Custom] mode – [HDR(HLG)]
- Log shooting mode ([Flexible ISO])

The configuration items related to image quality which are saved for each shooting mode are shown below.

✓: Item is saved.

×: Item is not saved.

Item		Shooting mode			
		[Custom]		[Flexible ISO]	
		[SDR(BT.709)]	[HDR(HLG)]		
[Shooting] menu	[ISO/Gain]		✓ ¹⁾		✓
	[White]	[Preset White]	✓		✓
		Other than above	✓		
	[White Setting]		✓		
	[Offset White]		✓		×
	[LUT On/Off]		×		✓
	[Noise Suppression]	[Setting(Custom)] / [Level(Custom)]	✓	✓	×
		[Setting(Flexible ISO)] / [Level(Flexible ISO)]	×		✓
[Paint/Look] menu	[Base Look]	[Select]	✓	✓	✓
		[Input] ²⁾	✓		
		[Output] ²⁾	✓		
		[AE Level Offset] ²⁾	✓		
	[Black]		✓	✓	×
	[Knee]	[Auto Knee]	✓	×	×
		Other than above	✓	✓	×
	[Detail]		✓	✓	×
	[Matrix]		✓	✓	×
	[Multi Matrix]		✓	✓	×

- 1) Separate ISO sensitivity settings may be saved for [Custom] – [SDR(BT.709)]/[HDR(HLG)].
- 2) Settings are saved for each [Base Look], and do not depend on the shooting mode.

TP1001804656

5-065-326-11(1) Copyright 2024 Sony Corporation

Web Menu Configuration

Press the [Settings] operation screen switching tab to display the settings screen.

Use the settings screen to configure the various setup items of the unit, including initial settings, network settings, shooting/playback settings using the web menu.

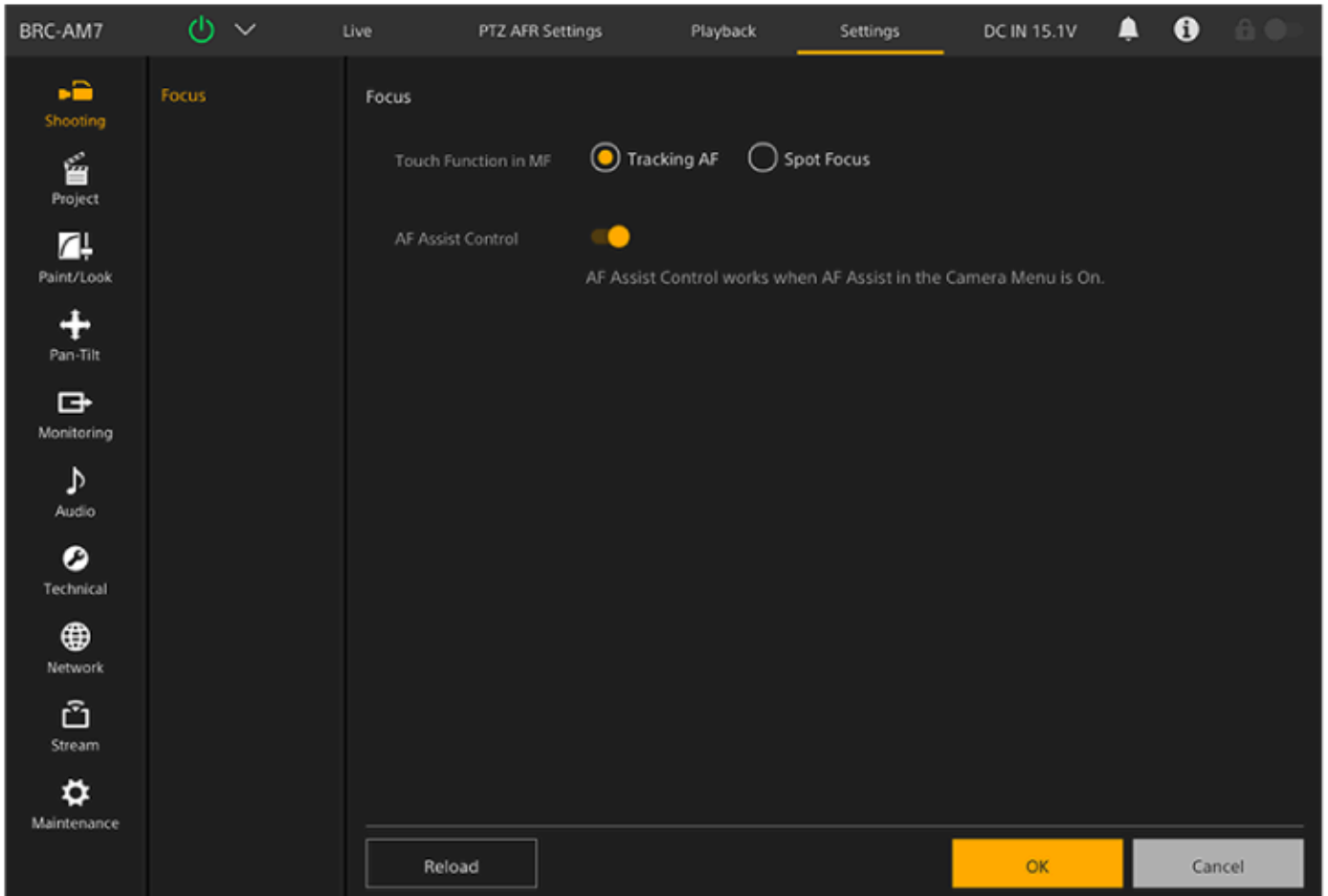

The menu comprises the following menus.

Menu configuration and hierarchy

Level 1	Level 1 description	Level 2
[Shooting]	Contains settings related to shooting.	[Focus]
[Project]	Contains basic project settings.	[Base Setting]
		[Rec Format]
		[Simul Rec]
		[Proxy Rec]
		[All File]
[Paint/Look]	Contains settings related to image quality.	[Base Look]

Level 1	Level 1 description	Level 2
[Pan-Tilt]	Contains settings related to the pan/tilt.	[P/T Speed]
		[P/T Acceleration]
		[P/T Range Limit]
		[P/T Direction]
		[P/T Preset]
[Monitoring]	Contains settings related to video output and the screen display.	[Output Format]
		[Output Display]
[Audio]	Contains settings related to audio.	[Audio Input]
		[Audio Output]
[Technical]	Contains settings for technical items.	[Tracking Data Output]
		[Tally]
		[IR Remote]
		[RCP/MSU]
[Network]	Contains settings related to networks.	[Camera Name]
		[User]
		[Wired LAN]
		[File Transfer]
		[FTP Server 1]
		[FTP Server 2]
		[FTP Server 3]
		[SSL]
		[SSH]
		[Referer Check]
[Brute Force Attack Protection]		
[Stream]	Contains settings related to streaming.	[Stream]
		[Video Stream]
		[Audio Stream]

Level 1	Level 1 description	Level 2
[Maintenance]	Contains devices settings, such as the clock and language.	[Language]
		[Clock Set]
		[Reset]
		[Information]
		[System Log]
		[HTTP Access Log]
		[Service]
		[EULA]
		[Software]

TP1001804657

Web Menu Operations

Press the [Settings] operation screen switching tab to display the settings screen to configure the various setup items of the unit, including initial settings, network settings, shooting/playback settings using the web menu.

Configure settings in the web menu on a tablet using touch operation or on a computer using mouse operation. Press the menu for the items you want to configure to display the setup items and their settings in that menu.

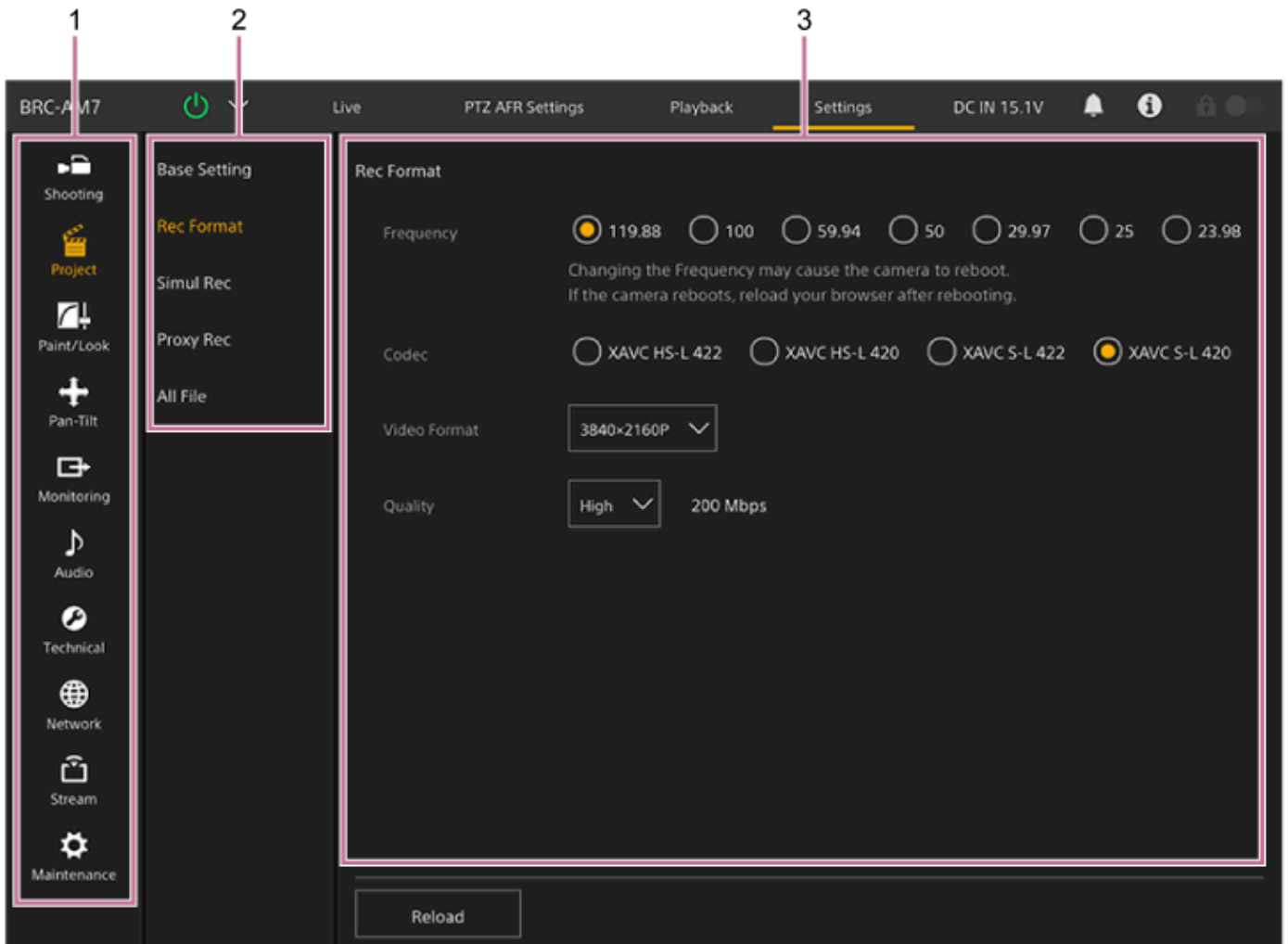

1. Menu (level 1)

2. Menu (level 2)

3. Setting

Configuration method

Value selection



Press the radio button for an item. The radio button for a selected item is displayed in orange.

Item on/off



Press the switch to turn the item on/off. The switch is orange when the item is turned on, and white when turned off.

Value selection from a list

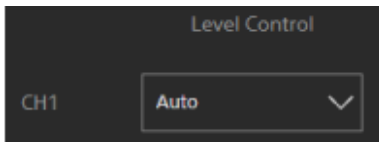

Press the drop-down button and select an item from the displayed list.

Numeric value selection



Press < or > to change the numeric value. If the numeric value is underlined, you can also enter a numeric value directly.

Character/number entry



Configuration on separate screen

Press the button to perform setup operations on a separate screen.

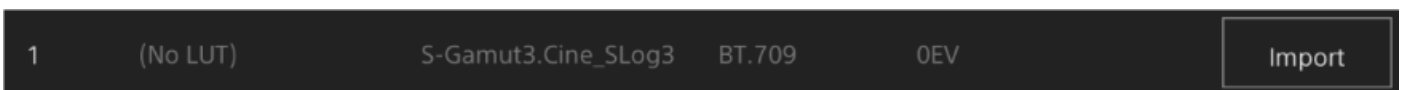

Guidance message

Information that helps you to configure some settings and messages that call attention to the user are displayed.

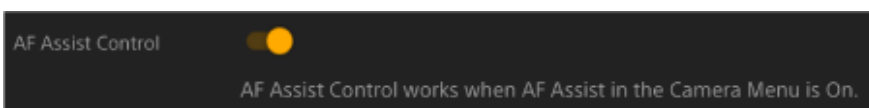

Saving a setting

When finished configuring a setting, press the [OK] button to save the setting.

Press the [Cancel] button to discard changes to a setting and revert to the previous setting.

Press the [Reload] button to update the screen display.

Note

- If you press the [Reload] button before saving a setting, changes to the setting will be discarded.
- If you move to a different page before saving a setting, changes to the setting will be discarded.

TP1001804658

Color Video Camera
BRC-AM7

[Focus]

Sets focus settings.

Item	Sub-item setting	Factory default	Description
[Touch Function in MF]	[Tracking AF] / [Spot Focus]	[Tracking AF]	Sets the operation when the camera image screen is touched in MF mode.
[AF Assist Control]	[On] / [Off]	[On]	<p>When set to [On], you can use the focus slider in the Web App during auto focus to adjust the focus position.</p> <ul style="list-style-type: none"> For details, see “Setting the Auto Focus Target Manually (AF Assist) Using the Web App.” <p>Note</p> <ul style="list-style-type: none"> This item is enabled only when [AF Assist] is set to [On] in the camera menu.

Related Topic

- [Setting the Auto Focus Target Manually \(AF Assist\) Using the Web App](#)

TP1001804659

Color Video Camera
BRC-AM7

[Base Setting]

Sets base settings.

Item	Sub-item setting	Factory default	Description
[Shooting Mode]	[Custom] / [Flexible ISO]	[Custom]	Sets the shooting mode. <ul style="list-style-type: none">● See “Shooting mode” in “Configuring Basic Operation.”
[Target Display]	[SDR(BT.709)] / [HDR(HLG)]	[SDR(BT.709)]	Sets the color gamut of the recording/output in custom mode.

Related Topic

- [Configuring Basic Operation](#)

TP1001804660

Color Video Camera
BRC-AM7

[Rec Format]

Sets recording format settings.

Item	Sub-item setting	Factory default	Description
[Frequency]	119.88 / 100 / 59.94 / 50 / 29.97 / 25 / 23.98	59.94	Selects the system frequency.
[Codec]	[XAVC HS-L 422] / [XAVC HS-L 420] / [XAVC S-L 422] / [XAVC S-L 420] / [XAVC S-I]	[XAVC S-L 420]	Sets the clip recording/playback codec.
[Video Format]	For details about settings, see the following topic. [Video Format] / [Quality] / [Bit Rate] Settings	–	Sets the image size and scan method.
[Quality]		–	Sets the recording bit rate.
[Bit Rate]		–	Displays the recording bit rate.

Related Topic

- [\[Video Format\] / \[Quality\] / \[Bit Rate\] Settings](#)

TP1001804661

Color Video Camera
BRC-AM7

[Simul Rec]

Sets 2-slot simultaneous recording mode settings (see “Recording to Memory Cards A and B Simultaneously (2-slot Simul Rec)”).

Item	Sub-item setting	Factory default	Description
[Setting]	[On] / [Off]	[Off]	Turns the simultaneous recording function on/off and sets the recording destination media.
[Rec Button]	[Slot A] / [Slot B] / [Slot A/Slot B]	[Slot A/Slot B]	Displays the record button assignment for each recording media.
[2nd Rec Button]	[Slot A] / [Slot B] / [Slot A/Slot B]	[Slot A/Slot B]	Set [Project] – [Simul Rec] – [Rec Button Set] in the camera menu.

Related Topic

- [Recording to Memory Cards A and B Simultaneously \(2-slot Simul Rec\)](#)

TP1001804662

Color Video Camera
BRC-AM7

[Proxy Rec]

Sets proxy recording mode settings (see “Proxy Recording Overview”).

Item	Sub-item setting	Factory default	Description
[Setting]	[On] / [Off]	[Off]	Turns proxy recording mode on/off.

Related Topic

- [Proxy Recording Overview](#)

TP1001804663

Color Video Camera
BRC-AM7

[All File]

Performs ALL file operations (see “Saving and Loading Configuration Data Overview”).

Item	Sub-item setting	Factory default	Description
[Load All File]	—	—	Load an ALL file into the unit from the device running the Web App. Note <ul style="list-style-type: none">When an ALL file is loaded into the unit, the unit will reboot. After rebooting, reload the page in the web browser.
[Save All File]	—	—	Save the settings of the unit to the device running the Web App as an ALL file.

Related Topic

- [Saving and Loading Configuration Data Overview](#)

TP1001804664

Color Video Camera
BRC-AM7

[Base Look]

You can load a base look into the unit.

A list of available base looks is displayed on the screen. The currently applied base look is indicated by a ● marker on the left of the base look number.

Base Look					
No.	Base Look Name	AUDIO IN CH	Output	AE Level Offset	
● 1	(No LUT)	S-Gamut3.Cine_SLog3	BT.709	0EV	Import
2	(No LUT)	S-Gamut3.Cine_SLog3	BT.709	0EV	Import
3	(No LUT)	S-Gamut3.Cine_SLog3	BT.709	0EV	Import
4	(No LUT)	S-Gamut3.Cine_SLog3	BT.709	0EV	Import
5	(No LUT)	S-Gamut3.Cine_SLog3	BT.709	0EV	Import
6	(No LUT)	S-Gamut3.Cine_SLog3	BT.709	0EV	Import
7	(No LUT)	S-Gamut3.Cine_SLog3	BT.709	0EV	Import
8	(No LUT)	S-Gamut3.Cine_SLog3	BT.709	0EV	Import
9	(No LUT)	S-Gamut3.Cine_SLog3	BT.709	0EV	Import
10	(No LUT)	S-Gamut3.Cine_SLog3	BT.709	0EV	Import
11	(No LUT)	S-Gamut3.Cine_SLog3	BT.709	0EV	Import

[No.]: Base look number

[Base Look Name]: Base look name

[Input]: Base look input signal

[Output]: Base look output signal

[AE Level Offset]: Base look exposure reference offset value

To add a base look

Press the [Import] button to import a new base look. Follow the on-screen instructions.

After importing, set appropriate values for [Input], [Output], and [AE Level Offset]. For details, see “Importing a Desired Base Look.”

Related Topic

- [Importing a Desired Base Look](#)

TP1001804665

[P/T Speed]

Sets settings related to the pan/tilt speed.

Item	Sub-item setting	Factory default	Description
[Speed Step]	[Normal] / [Extended]	[Extended]	<p>Sets the number of speed steps of the pan/tilt drive.</p> <p>[Normal]: Speed can be specified using 24-step range.</p> <p>[Extended]: Speed can be specified using 127-step range.</p> <p>Hint</p> <ul style="list-style-type: none"> The maximum speed to avoid overly sensitive joystick movements in the Web App is limited to 60 °/sec (when [Speed Mode] is set to [Normal]) or 40 °/sec (when [Speed Mode] is set to [Slow]).
[Speed Mode]	[Normal] / [Slow]	[Normal]	<p>Sets the speed mode of the pan/tilt drive.</p> <p>When [Speed Step] is set to [Normal] (24-step)</p> <ul style="list-style-type: none"> When [Speed Mode] is set to [Normal]: 0.05 °/sec (min) to 60 °/sec (max) When [Speed Mode] is set to [Slow]: 0.05°/sec (min) to 40°/sec (max) <p>When [Speed Step] is set to [Extended] (127-step)</p> <ul style="list-style-type: none"> When [Speed Mode] is set to [Normal]: 0.02 °/sec (min) to 180 °/sec (max) When [Speed Mode] is set to [Slow]: 0.004°/sec (min) to 180 °/sec (max)

TP1001804666

Color Video Camera
BRC-AM7

[P/T Acceleration]

Sets settings related to the pan/tilt speed.

Item	Sub-item setting	Factory default	Description
[Acceleration]	1 to 9	8	Selects the acceleration/deceleration for pan/tilt operations. The larger the number, the higher the acceleration.

TP1001804667

[P/T Range Limit]

Sets settings related to limiting the pan/tilt operating range.
Set the pan/tilt operating range limits using the following screen.

Note

- When the unit is turned on or pan/tilt reset is executed, this range limit setting is ignored. This function cannot be used to avoid obstacles near the unit.

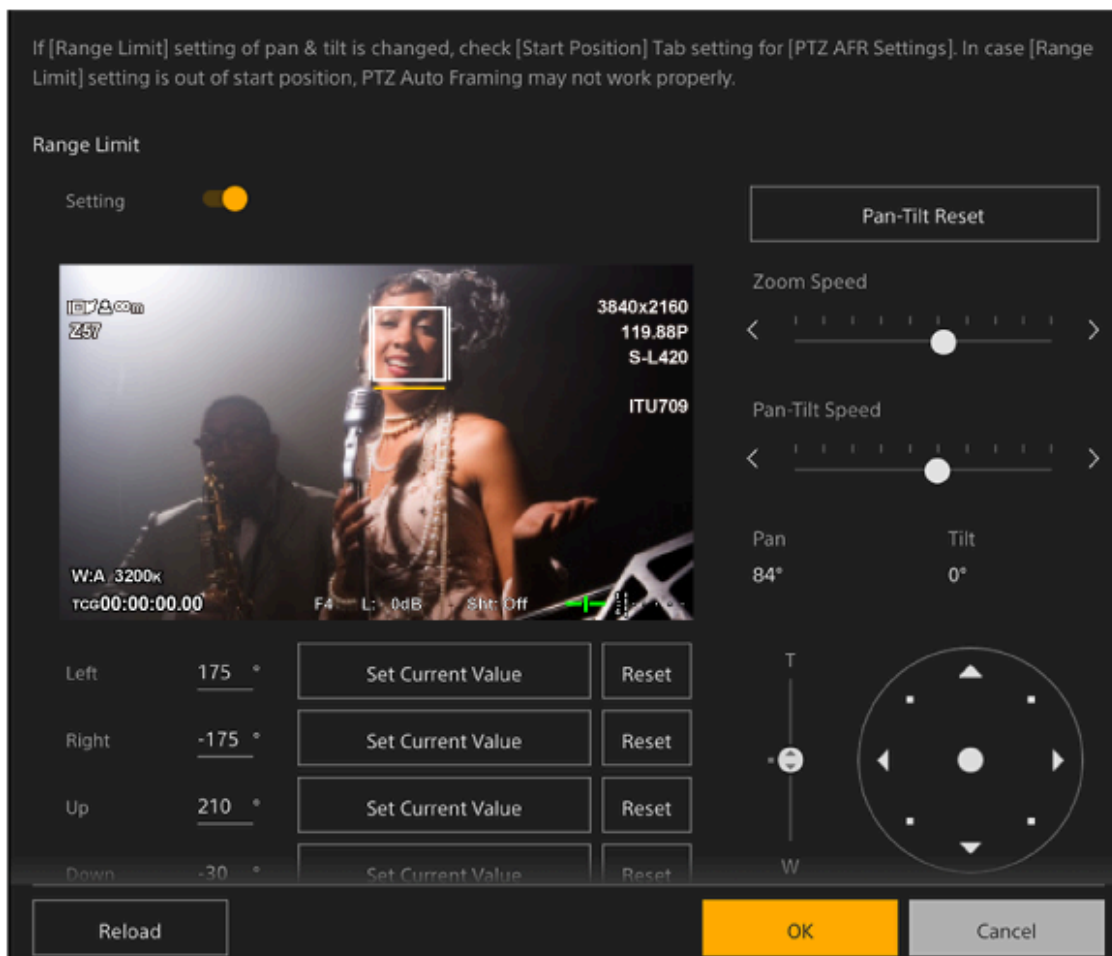

- 1 Set the [Setting] switch to the on position.**

The pan-tilt operating range limit function becomes enabled.
- 2 Check the image using the pan/tilt controls of the camera.**
- 3 To set the positions at which to limit operation, press the [Left], [Right], [Up], [Down] – [Set Current Value] button at those positions.**

[Left]: Left side of camera
[Right]: Right side of camera
[Up]: Top side of camera
[Down]: Bottom side of camera

Left	175 °	Set Current Value	Reset
Right	-175 °	Set Current Value	Reset
Up	210 °	Set Current Value	Reset
Down	-30 °	Set Current Value	Reset

The limit positions are set and are displayed as numeric values (angle).
To cancel a limit, press the [Reset] button for the individual positions.

4 Press the [OK] button.

The pan/tilt operation is restricted to stay within the configured limit positions.

Note

- Camera positions outside the limit positions cannot be saved as a preset.
- If the [Pan-Tilt] – [P/T Direction] – [Ceiling] setting is changed, the configured limit position settings are returned to the factory defaults.
- The setting cannot be changed during playback, during thumbnail display, when a pan/tilt error occurs, and when pan/tilt is not initialized.

TP1001804668

[P/T Direction]

Sets settings related to the pan/tilt direction.

Item	Sub-item setting	Factory default	Description
[Ceiling]	[On] / [Off]	[Off]	When the unit is mounted on a desktop, set to [Off]. When the unit is mounted on a ceiling, set to [On]. When [Ceiling] is set to [On], [Pan Direction] is automatically set to [Opposite].
[Pan Direction]	[Normal] / [Opposite]	[Normal]	Sets the pan drive direction. When the setting is changed, the drive direction reverses.
[Tilt Direction]	[Normal] / [Opposite]	[Normal]	Sets the tilt drive direction. When the setting is changed, the drive direction reverses.

Note

- When a changed [Ceiling] setting is applied, all preset positions are deleted since the pan/tilt coordinates would become inverted.

The pan/tilt drive range changes as shown in the following diagram depending on the [Ceiling] setting.

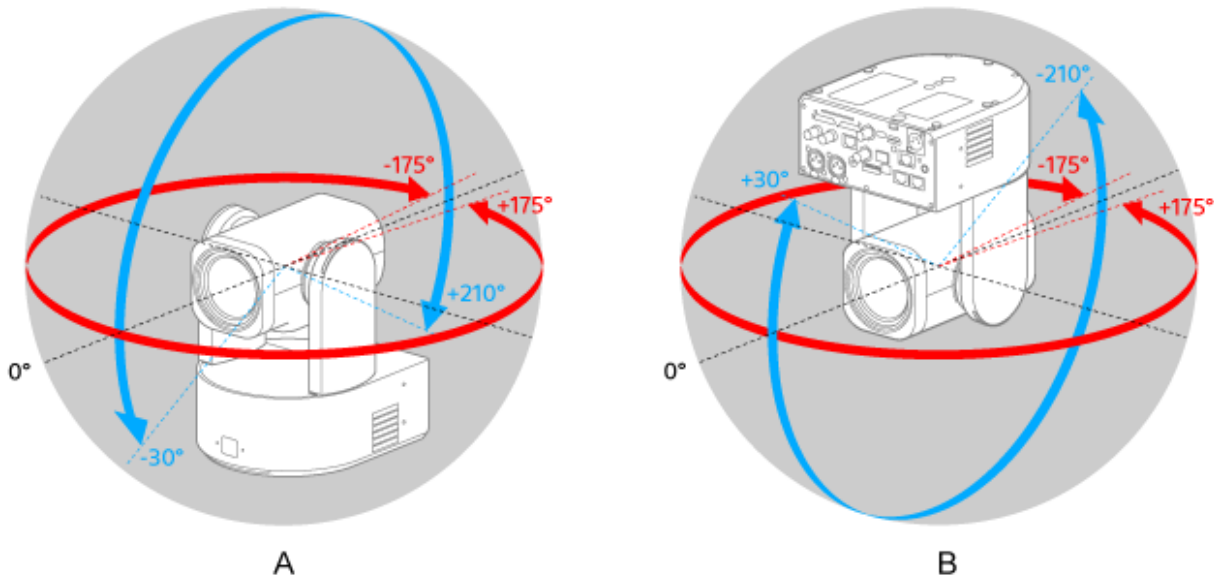

A: When [Ceiling] is set to [Off]

B: When [Ceiling] is set to [On]

Color Video Camera
BRC-AM7

[P/T Preset]

Sets settings related to preset positions.

[Acceleration]

Sets the acceleration when a preset position is recalled.

Item	Sub-item setting	Factory default	Description
[Ramp Curve]	1 to 9	9	Sets the pan/tilt preset acceleration. The larger the number, the higher the acceleration.

[Pan-Tilt Speed]

Sets the pan/tilt speed.

Item	Sub-item setting	Factory default	Description
[Setting Way]	[Separate] / [Common]	[Separate]	Sets whether preset position pan/tilt speeds are configured separately or use a common setting.
[Default Speed]	1 to 127	127	Sets the drive speed for presets when a preset is saved.
[Common Speed]	1 to 127	127	Sets the common speed for presets.

[Default]

Sets the default values that are configured when a preset position is saved.

Item	Sub-item setting	Factory default	Description
[Zoom Speed]	0 to 32766	32766	Sets the zoom speed.
[Focus Recall]	[On] / [Off]	[On]	Sets whether focus settings are restored.
[MF Speed]	0 to 32766	32766	Sets the focus speed for manual focus.

TP1001804670

Color Video Camera
BRC-AM7

[Output Format]

Sets output format settings.

Item	Sub-item setting	Factory default	Description
[SDI1/SDI2/HDMI]	For details about setup items, see "Output Formats and Limitations."	–	Sets the output resolution.

Related Topic

- [Output Formats and Limitations](#)

TP1001804671

Color Video Camera
BRC-AM7

[Output Display]

Sets settings related to output signals.

Item	Sub-item setting	Factory default	Description
[SDI1]	[On] / [Off]	[Off]	Sets whether the menu and status are embedded in the SDI1 output signal.
[SDI2/HDMI/Stream]	[On] / [Off]	[On]	Sets whether the menu and status are embedded in the SDI2, HDMI, and Stream output signal. Note <ul style="list-style-type: none">This setting is also applied to the HDMI output signal image, streaming output image, and the image in the Web App camera image panel.

TP1001804672

[Audio Input]

Sets settings related to CH1 to CH4 audio input.

Item	Sub-item setting	Factory default	Description
[AUDIO IN 1 Select]	[MIC] / [LINE]	[MIC]	Selects the type of device connected to the AUDIO IN 1 connector.
[AUDIO IN 2 Select]	[MIC] / [LINE]	[MIC]	Selects the type of device connected to the AUDIO IN 2 connector.
[AUDIO IN 1 MIC +48V]	[On] / [Off]	[Off]	Enables/disables the +48 V phantom power supply of the device connected to the AUDIO IN 1 connector.
[AUDIO IN 2 MIC +48V]	[On] / [Off]	[Off]	Enables/disables the +48 V phantom power supply of the device connected to the AUDIO IN 2 connector.
[Level Control]	[Auto] / [Manual]	[Auto]	Selects audio input level automatic adjustment or manual adjustment.
[Level]	0 to 99	49	Sets the input level.
[Input Select]	[Off] / [AUDIO IN 1] / [AUDIO IN 2] / [MIC (L)] / [MIC (R)]	CH1: [AUDIO IN 1] CH2: [AUDIO IN 2] CH3: [AUDIO IN 1] CH4: [AUDIO IN 2]	Sets the audio input source. CH1: [AUDIO IN 1] / [MIC (L)] CH2: [AUDIO IN 1] / [AUDIO IN 2] / [MIC (R)] CH3: [Off] / [AUDIO IN 1] / [MIC (L)] CH4: [Off] / [AUDIO IN 1] / [AUDIO IN 2] / [MIC (R)]
[Wind Filter]	[On] / [Off]	[Off]	Turns the wind noise reduction filter on/off.

Color Video Camera
BRC-AM7

[Audio Output]

Sets settings related to audio output.

Item	Sub-item setting	Factory default	Description
[SDI2/HDMI/Strm Out CH]	[CH1/CH2] / [CH3/CH4]	[CH1/CH2]	Sets the combination of audio channels for the SDI2/HDMI/streaming output.

Note

- This setting is also applied to the streaming output audio.

TP1001804674

Color Video Camera
BRC-AM7

[Tracking Data Output]

Sets settings related to tracking information (free-d protocol compliant) output.

Item	Sub-item setting	Factory default	Description
[Transfer Mode]	[Off] / [Always] / [On Demand]	[Off]	Selects the tracking information output method.
[Camera ID]	0 to 255	255	Sets the ID of the unit.
[Destination Address]	IPv4 address	–	When [Transfer Mode] is set to [Always], sets the tracking information destination IP address.
[Destination Port]	1024 to 65534	40000	When [Transfer Mode] is set to [Always], sets the tracking information destination port number.
[Listen Port]	1024 to 65534	40000	When [Transfer Mode] is set to [On Demand], sets the port number on the unit for listening to requests from clients.

TP1001804675

Color Video Camera
BRC-AM7

[Tally]

Sets recording/tally lamp settings (see “Connecting a Tally Signal”).

[Tally]

Sets settings related to the recording/tally lamp.

Item	Sub-item setting	Factory default	Description
[Tally Lamp Brightness]	[High] / [Low] / [Off]	[High]	Sets the brightness of the recording/tally lamp.
[G Tally Lamp]	[Enable] / [Disable]	[Enable]	Enables/disables the G (green) tally lamp.
[Y Tally Lamp]	[Enable] / [Disable]	[Enable]	Enables/disables the Y (yellow) tally lamp.
[Tally Control]	[External] / [Internal] / [PTZ AFR]	[Internal]	Selects the target for accepting the recording/tally lamp control information of the unit.

[TSL UMD]

Sets the tally control method using the TSL UMD protocol.

Item	Sub-item setting	Factory default	Description
[Setting]	[On] / [Off]	[Off]	Enables/disables tally control using the TSL UMD protocol.
[Index]	0 to 65534	1	Sets the index number for receiving tally control using the TSL UMD protocol.
[Port Number]	1024 to 65534	8900	Sets the port number for receiving tally control using the TSL UMD protocol.

Related Topic

- [Connecting a Tally Signal](#)

TP1001804676

Color Video Camera
BRC-AM7

[IR Remote]

Sets settings related to the infrared remote control.

Item	Sub-item setting	Factory default	Description
[Setting]	[On] / [Off]	[On]	Enables/disables operation of the unit from the infrared remote control.

TP1001804677

Color Video Camera
BRC-AM7

[RCP/MSU]

Configures setting when an RCP/MSU (option) is connected.
For details, see “Connecting an RCP/MSU (option).”

Item	Sub-item setting	Factory default	Description
[CNS Mode]	[Off] / [Bridge] / [MCS] / [PC Control]	[Off]	Sets the connection mode for the RCP/MSU.
[Master IP Address]	IPv4 address	0.0.0.0	Sets the IP address of the master device when building a LAN-based multi-camera system.
[Camera No.]	Enter a camera number (1 to 96).	1	Sets a unique camera number within the system when building a LAN-based multi-camera system.

Note

- Configure settings on the RCP/MSU as required.
- An MSU is required for a multi-camera system.
- When using multiple MSU units, set one MSU unit as the master and set all other MSU units as clients.

TP1001804678

Color Video Camera
BRC-AM7

[Camera Name]

Sets settings related to the camera name (unit name).

Item	Sub-item setting	Factory default	Description
[Camera Name]	–	BRC-AM7	Sets the camera name.

Up to eight (0 to 8) of the following characters can be entered for Camera Name.

Alphanumeric characters

Symbols (space !#\$%&'*+,-./;<=>?@[^_`{|})

TP1001804679

Color Video Camera
BRC-AM7

[User]

Sets settings related to user access of the unit.

Settings related to administrator users (Administrator) (required)

Item	Sub-item setting	Factory default	Description
[User Name]	–	admin	Sets the user name.
[Current Password]	–	–	When changing the password, enter the current password.
[New Password]	–	–	Enter the new password.
[Re-Type Password]	–	–	Enter the new password again for confirmation.

Settings related to general users (User 1 to User 9) (optional)

Item	Sub-item setting	Factory default	Description
[User Name]	–	–	Sets the user name.
[Current Password]	–	–	When changing the password, enter the current password.
[New Password]	–	–	Enter the new password.
[Re-Type Password]	–	–	Enter the new password again for confirmation.

TP1001804680

Color Video Camera
BRC-AM7

[Wired LAN]

[Status]

Displays the network status.

Item	Sub-item setting	Factory default	Description
[Host Name]	–	–	Displays the host name.
[MAC Address]	–	–	Displays the MAC address of the unit.
[Ethernet Status]	–	–	Displays the current communication speed.
[IP Address]	–	–	Displays the IP address of the unit.
[Subnet Mask]	–	–	Displays the subnet mask of the unit.
[Gateway]	–	–	Displays the IPv4 default gateway of the unit.
[Primary DNS Server]	–	–	Displays the primary DNS server of the unit.
[Secondary DNS Server]	–	–	Displays the secondary DNS server of the unit.
[IPv6 Address 1]	–	–	Displays IPv6 address 1 of the unit.
[IPv6 Address 2]	–	–	Displays IPv6 address 2 of the unit.
[IPv6 Gateway]	–	–	Displays the IPv6 default gateway of the unit.
[Link-local IPv6 Address]	–	–	Displays the IPv6 link-local address of the unit.

[IPv4]

Sets settings related to the IPv4 network.

Item	Sub-item setting	Factory default	Description
[DHCP]	[On] / [Off]	[On]	Turns [DHCP] on/off.
[IP Address]	–	–	Sets the IPv4 address when [DHCP] is set to off.
[Subnet Mask]	–	–	Sets the subnet mask when [DHCP] is set to off.
[Gateway]	–	–	Sets the IPv4 default gateway when [DHCP] is set to off.

[IPv6]

Sets settings related to the IPv6 network.

Item	Sub-item setting	Factory default	Description
[Obtain an IP Address Automatically]	[On] / [Off]	[On]	Turns auto IPv6 address acquisition on/off.

Item	Sub-item setting	Factory default	Description
[IP Address]	–	–	Sets the IPv6 address when [Obtain an IP Address Automatically] is set to off.
[Prefix Length]	–	–	Sets the prefix when [Obtain an IP Address Automatically] is set to off.
[Gateway]	–	–	Sets the IPv6 default gateway when [Obtain an IP Address Automatically] is set to off.

[Common]

Sets settings common to IPv4/IPv6 networks.

Item	Sub-item setting	Factory default	Description
[HTTP Port]	80, 1024 to 65534	80	Sets the HTTP port number.
[DNS Auto]	[On] / [Off]	[On]	Sets whether to obtain the DNS addresses from the DHCP server.
[Primary DNS Server]	IPv4/IPv6 address	–	Sets the primary DNS server when [DNS Auto] is set to off.
[Secondary DNS Server]	IPv4/IPv6 address	–	Sets the secondary DNS server when [DNS Auto] is set to off.

TP1001804681

Color Video Camera
BRC-AM7

[File Transfer]

Sets settings related to file transfers.

Item	Sub-item setting	Factory default	Description
[Auto Upload (Proxy)]	[On] / [Off]	[Off]	Turns proxy clip auto upload on/off.
[Default Upload Server]	Server Settings1 to 3 – [Display Name]	[Server Settings1]	Selects the upload server for files. The server selected here becomes the auto upload destination for proxy clips, and the upload destination for files from the thumbnail screen. Displays the [Display Name] settings configured in [Server Settings1 to 3].

TP1001804682

[FTP Server 1], [FTP Server 2], [FTP Server 3]

Sets settings related to file FTP transfers.

The settings are common for [FTP Server 1], [FTP Server 2], and [FTP Server 3].

Item	Sub-item setting	Factory default	Description
[Display Name]	–	–	Sets the display name shown in the transfer destination setup menu.
[Service]	–	–	Displays the type of server.
[Host Name]	–	–	Sets the host name of the transfer destination server.
[Port]	21, 990, 1024 to 65534	21	Sets the port number of the transfer destination server.
[User Name]	–	–	Sets the user name for authentication of the transfer destination server connection.
[Password]	–	–	Sets the authentication password of the transfer destination server connection.
[Passive Mode]	[On] / [Off]	[Off]	Turns passive mode on/off.
[Destination Directory]	–	–	Sets the name of the transfer destination directory.
[Using Secure Protocol]	[On] / [Off]	[Off]	Sets whether to use ([On]) or not use ([Off]) secure FTP transfer.
[Root Certificate]	–	–	Loads the root certificate for secure FTP transfer. Press the [Load] button and select a root certificate on the displayed screen. Press the [Delete] button to delete the loaded root certificate.
[Root Certificate Status]	–	–	Displays the load status of the root certificate.
[Reset]	–	–	Resets the [Server Settings] settings to the defaults.

Color Video Camera
BRC-AM7

[SSL]

Sets settings related to SSL.

[SSL]

Enables/disables the SSL function.

Item	Sub-item setting	Factory default	Description
[Function]	[Disable] / [Enable] / [Enable (Allow HTTP connection for some clients)]	[Disable]	Enables/disables the SSL function.

[SSL Server Authentication]

Sets settings related to SSL server authentication.

Item	Sub-item setting	Factory default	Description
[Certificate Options]	[Use a self-signed certificate (For test use)] / [Use an external certificate]	–	Sets the installation method of the SSL server certificate.
[Status]	–	–	Displays the validity of the SSL server certificate when [Certificate Options] is set to [Use a self-signed certificate (For test use)].
[Issuer DN]	–	–	Displays the distinguished name of the issuer of the SSL server certificate when [Certificate Options] is set to [Use a self-signed certificate (For test use)].
[Subject DN]	–	–	Displays the distinguished name of the subject of the SSL server certificate when [Certificate Options] is set to [Use a self-signed certificate (For test use)].
[Available Period]	–	–	Displays the valid period of the SSL server certificate when [Certificate Options] is set to [Use a self-signed certificate (For test use)].
[Extended Key Usage]	–	–	Displays the extended key usage method when [Certificate Options] is set to [Use a self-signed certificate (For test use)].
[Delete]	–	–	This button is displayed when [Certificate Options] is set to [Use a self-signed certificate (For test use)]. Deletes the installed SSL server certificate.
[Import]	–	–	Installs an external SSL server certificate from a list when [Certificate Options] is set to [Use an external certificate].

Item	Sub-item setting	Factory default	Description
[Private Key Password]	–	–	Sets the password for the private key information of the SSL server certificate when [Certificate Options] is set to [Use an external certificate].
[Reset]	–	–	This button clears the private key password display for entry of a new password.
[Self-Signed Certificate Generation]	–	–	Press the [Generate] button to generate a self-signed certificate when [Certificate Options] is set to [Use a self-signed certificate (For test use)].

TP1001804684

5-065-326-11(1) Copyright 2024 Sony Corporation

Color Video Camera
BRC-AM7

[SSH]

Sets settings related to SSH.

SSH must be enabled to use the unit in applications using the Camera Remote SDK. Enable only for applications that you trust.

Sony shall not be liable for any loss arising from the operation of the application.

[SSH]

Set the SSH setting.

Item	Sub-item setting	Factory default	Description
[Setting]	[On] / [Off]	–	Enables/disables the SSH function.
[User Name]	–	–	Sets/displays the user name.
[Password]	–	–	Sets the password.
[Fingerprint]	–	–	Displays the fingerprint.
[Reset]	–	–	Resets the user name and password.

[Camera]

Displays the model name and serial number of the camera.

Item	Sub-item setting	Factory default	Description
[Model Name]	–	–	Displays the model name of the camera.
[Serial Number]	–	–	Displays the serial number of the camera.

TP1001804685

Color Video Camera
BRC-AM7

[Referer Check]

Sets settings related to Referer checks.

Item	Sub-item setting	Factory default	Description
[Setting]	[On] / [Off]	[On]	Enables/disables the Referer check function.

[Exception List]

Sets settings related to the Referer check exception list.

Exception List

No. 1 Host Name Port Number 80

Set Delete

No.	Host Name	Port Number
1		80
2		80
3		80
4		80
5		80
6		80
7		80
8		80
9		80
10		80

Item	Sub-item setting	Factory default	Description
[No.]	1 to 10	–	Sets the exception number from the list.
[Host Name]	–	–	Sets the host name of the exception.
[Port Number]	–	–	Sets the port number of the exception.
[Set]	–	–	Press to register the configured exception in the exception list.
[Delete]	–	–	Select an exception that you want to delete and press the button to delete the registered exception from the exception list.

Color Video Camera
BRC-AM7

[Brute Force Attack Protection]

Sets settings related to brute force attack prevention.

Item	Sub-item setting	Factory default	Description
[Setting]	[On] / [Off]	[On]	Turns [Brute Force Attack Protection] on/off.
[Count]	3 to 100	8	Sets the number of attempts that will be considered as an attack. Enabled when [Setting] is set to on.
[Release Mode]	[Always] / [Timer]	[Timer]	Sets the release condition. Enabled when [Setting] is set to on. [Always]: Do not delete from attacker list. [Timer]: Delete from attacker list after the release time set using [Release Time] has elapsed.
[Release Time]	30 to 86400 s	60	Sets the release time. Enabled when [Setting] is set to on. When [Release Mode] is set to [Timer], entries are deleted from the attacker list after the release time has elapsed.

When an attacker is detected, the attacker list information is displayed.

TP1001804687

Color Video Camera
BRC-AM7

[Stream]

Sets streaming settings (see “About Streaming”).

[Stream Setting]

Sets settings related to the streaming protocol.

Item	Sub-item setting	Factory default	Description
[Setting]	[RTSP] / [RTMP] / [SRT-Caller] / [SRT-Listener] / [NDI HX] / [Off]	[RTSP]	Selects the streaming protocol.

Note

- To use RTMP, set [Stream] – [Audio Stream] – [Setting] to [On] beforehand.

[RTSP]

The following items are displayed when [Stream Setting] is set to [RTSP].
Sets settings related to RTSP streaming.

Item	Sub-item setting	Factory default	Description
[Port Number]	554, 1024 to 65534	554	Sets the RTSP port number.
[Time Out]	0 to 600	60	Sets the timeout of the Keep Alive command for RTSP streaming.
[Authentication]	[On] / [Off]	[On]	Turns the RTSP authentication function on/off.
[Video Port Number 1]	1024 to 65534	51000	Sets the port number for sending video 1 for RTSP unicast streaming.
[Video Port Number 2]	1024 to 65534	53000	Sets the port number for sending video 2 for RTSP unicast streaming.
[Audio Port Number]	1024 to 65534	57000	Sets the port number for sending audio for RTSP unicast streaming.

[RTMP]

The following items are displayed when [Stream Setting] is set to [RTMP].
Sets settings related to RTMP streaming.

Item	Sub-item setting	Factory default	Description
[Server URL]	–	–	Sets the RTMP or RTMPS connection destination URL.
[Stream Key]	–	–	Sets the stream key obtained from the RTMP server side.

Item	Sub-item setting	Factory default	Description
[Root Certificate]	–	–	Loads the root certificate required for connection with the RTMP server. Press the [Load] button and select a root certificate on the displayed screen. Press the [Delete] button to delete the loaded root certificate. The status is displayed in [Root Certificate Status].

[SRT]

The following items are displayed when [Stream Setting] is set to [SRT-Caller] or [SRT-Listener].
Sets settings related to SRT streaming.

Item	Sub-item setting	Factory default	Description
[Destination]	–	–	Sets the connection destination URL when the unit is operating as a caller.
[Port Number]	1024 to 65534	4201	Sets the port number for listening when the unit is operating as a listener.
[Latency]	20 to 8000 ms	120	Sets the latency.
[TTL]	1 to 255	64	Sets the TTL value.
[Encryption]	[Off] / [AES128] / [AES256]	[Off]	Enables/disables encryption and sets the encryption method.
[Passphrase]	0 or string of 10 to 79 characters	0	Sets the passphrase used for encryption. Press [Clear] to clear the entered passphrase.
[ARC]	[On] / [Off]	[On]	Turns the Adaptive Rate Control function on/off.

NDI|HX

The following items are displayed when [Stream Setting] is set to [NDI|HX].
Sets settings related to NDI|HX.

Item	Sub-item setting	Factory default	Description
[Source Name]	–	–	Displays the NDI source name.
[Group]	[On] / [Off]	[Off]	Turns the NDI grouping function on/off.
[Group Name]	–	–	Displayed when the NDI grouping function is set to [On]. Sets the group name.
[Discovery Server 1]	–	–	Sets NDI discovery server 1.
[Discovery Server 2]	–	–	Sets NDI discovery server 2.
[Multicast Mode]	[On] / [Off]	[Off]	Turns multicast streaming on/off.
[Multicast Prefix]	239.255.0.0	239.255.0.0	Displayed when [Multicast Mode] is set to [On]. Sets the prefix to use for multicast streaming.

Item	Sub-item setting	Factory default	Description
[Multicast Netmask]	255.255.0.0	255.255.0.0	Displayed when [Multicast Mode] is set to [On]. Sets the netmask that determines the multicast address range.
[Multicast TTL]	1 to 256	3	Displayed when [Multicast Mode] is set to [On]. Sets the TTL value for multicast streaming.
[Multi-TCP Mode]	[On] / [Off]	[Off]	Turns Multi-TCP mode on/off.
[Unicast UDP Mode]	[On] / [Off]	[On]	Turns Unicast UDP mode on/off.

Related Topic

- [About Streaming](#)

TP1001804688

Color Video Camera
BRC-AM7

[Video Stream]

Sets settings related to the streaming video codecs.

[Video Stream 1]

Sets settings related to video codec 1.

Item	Sub-item setting	Factory default	Description
[Codec 1]	[H.264] / [H.265]	[H.264]	Sets the codec of image 1.
[Size 1]	3840×2160 / 1920×1080 / 1280×720 / 640×360	1920×1080	Sets the picture size of image 1.
[Frame Rate 1]	<ul style="list-style-type: none"> For details about supported frame rates, see “Setting the Video Codec for Streaming.” 	–	Sets the frame rate of image 1.
[I-Picture Mode 1]	[Time] / [Frame]	[Time]	Sets the IDR-Frame insertion interval for image 1 as a time or number of frames.
[I-Picture Interval 1]	1 / 2 / 3 / 4 / 5 s	1	Displayed when [I-Picture Mode 1] is set to [Time]. Sets the IDR-Frame insertion interval for H.264 and H.265 as a time.
[I-Picture Ratio 1]	15 to 300 frames	30	Displayed when [I-Picture Mode 1] is set to [Frame]. Sets the IDR-Frame insertion interval for H.264 and H.265 as a number of frames.
[Profile 1]	[H.264]: [high] / [main] / [baseline] [H.265]: [main]	[H.264]: [high]	Sets the H.264 or H.265 profile.
[Bit Rate Compression Mode 1]	[CBR] / [VBR]	[VBR]	Sets the bit rate compression mode of image 1.
[Bit Rate 1]	512 / 768 / 1000 / 2000 / 3000 / 4000 / 5000 / 6000 / 7000 / 8000 / 16000 / 24000 / 32000 / 50000 / 64000 / 80000 kbps	16000	Sets the bit rate target value when [Bit Rate Compression Mode 1] is set to [CBR].
[Quality 1]	1 / 2 / 3 / 4 / 5 / 6 / 7 / 8 / 9 / 10	6	Displayed when [Bit Rate Compression Mode 1] is set to [VBR]. Sets the H.264 or H.265 quality.

[Video Stream 2]

Sets settings related to video codec 2.

Item	Sub-item setting	Factory default	Description
[Codec 2]	[H.264] / [H.265] / [Off]	[Off]	Sets the codec of image 2.
[Size 2]	3840×2160 / 1920×1080 / 1280×720 / 640×360 / 512×270	1920×1080	Sets the picture size of image 2.
[Frame Rate 2]	<ul style="list-style-type: none"> For details about supported frame rates, see “Setting the Video Codec for Streaming.” 	–	Displayed when [Codec 2] is not set to [Off]. Sets the frame rate of image 2.
[I-Picture Mode 2]	[Time] / [Frame]	[Time]	Displayed when [Codec 2] is not set to [Off]. Sets the IDR-Frame insertion interval for image 2 as a time or number of frames.
[I-Picture Interval 2]	1 / 2 / 3 / 4 / 5 s	1	Displayed when both [Codec 2] is not set to [Off] and [I-Picture Mode 2] is set to [Time]. Sets the IDR-Frame insertion interval for H.264 and H.265 as a time.
[I-Picture Ratio 2]	15 to 300 frames	30	Displayed when both [Codec 2] is not set to [Off] and [I-Picture Mode 2] is set to [Frame]. Sets the IDR-Frame insertion interval for H.264 and H.265 as a number of frames.
[Profile 2]	[H.264]: [high] / [main] / [baseline] [H.265]: [main]	–	Sets the H.264 or H.265 profile.
[Bit Rate Compression Mode 2]	[CBR] / [VBR]	[VBR]	Displayed when [Codec 2] is not set to [Off]. Sets the bit rate compression mode of image 2.
[Bit Rate 2]	512 / 768 / 1000 / 2000 / 3000 / 4000 / 5000 / 6000 / 7000 / 8000 / 16000 / 24000 / 32000 / 50000 / 64000 / 80000 kbps	8000	Sets the bit rate target value when both [Codec 2] is not set to [Off] and [Bit Rate Compression Mode 2] is set to [CBR].
[Quality 2]	1 / 2 / 3 / 4 / 5 / 6 / 7 / 8 / 9 / 10	6	Displayed when both [Codec 2] is not set to [Off] and [Bit Rate Compression Mode 2] is set to [VBR]. Sets the H.264 or H.265 quality.

[Video Stream 3]

Sets settings related to video codec 3.

Item	Sub-item setting	Factory default	Description
[Codec 3]	[JPEG]	[JPEG]	Sets the codec of image 3.
[Size 3]	1280×720 / 640×360	1280×720	Sets the picture size of image 3.

Item	Sub-item setting	Factory default	Description
[Frame Rate 3]	<ul style="list-style-type: none"> For details about supported frame rates, see “Setting the Video Codec for Streaming.” 	–	Sets the frame rate of image 3.
[Quality 3]	1 / 2 / 3 / 4 / 5 / 6 / 7 / 8 / 9 / 10	6	Sets the quality.

Related Topic

- [Setting the Video Codec for Streaming](#)

TP1001804689

5-065-326-11(1) Copyright 2024 Sony Corporation

Color Video Camera
BRC-AM7

[Audio Stream]

Sets settings related to the streaming audio codec.

Item	Sub-item setting	Factory default	Description
[Setting]	[On] / [Off]	[Off]	Turns audio streaming on/off.
[Codec]	[AAC (128kbps)] / [AAC (256kbps)]	[AAC (128kbps)]	Enabled when [Setting] is set to on. Sets the audio codec for streaming.

TP1001804690

Color Video Camera
BRC-AM7

[Language]

Sets the display language.

Item	Sub-item setting	Factory default	Description
[Language]	[English] / [日本語] / [Français] / [Deutsch] / [Italiano] / [Español] / [Português] / [русский] / [Polski] / [Türkçe] / [中文(繁)] / [中文(简)] / [한국어] / [हिंदी]	[English]	Sets the display language.

TP1001804691

[Clock Set]

Sets internal clock settings.

Item	Sub-item setting	Factory default	Description
[Current Date & Time]	–	–	Displays the current time configured on the unit.
[PC Clock]	–	–	Displays the current time of the tablet or computer used for configuration.
[Date & Time Format]	[yyyy-mm-dd hh:mm:ss] / [mm-dd-yyyy hh:mm:ss] / [dd-mm-yyyy hh:mm:ss]	[yyyy-mm-dd hh:mm:ss]	Sets the display format of the date and time.
[12 h] / [24 h]	[12 h] / [24 h]	[24 h]	Sets the time to 12-hour/24-hour display format.
[Time Setting]	[Keep current setting] / [Synchronize with PC] / [Manual setting] / [Synchronize with NTP]	–	Sets the configuration method of the date and time.
[yy-mm-dd hh:mm:ss]	yy: 19 to 37 mm: 01 to 12 dd: 01 to 31 hh: 00 to 23 mm: 00 to 59 ss: 00 to 59 (seconds)	–	Displayed when [Time Setting] is set to [Manual setting]. Sets the date and time manually.
[NTP Auto]	[On] / [Off]	[Off]	Displayed when [Time Setting] is set to [Synchronize with NTP]. Sets whether to obtain the IP address of the NTP server from the DHCP server.
[NTP Server]	IPv4/IPv6 address or host name	–	Displayed when both [Time Setting] is set to [Synchronize with NTP] and [NTP Auto] is set to [Off]. Specifies the NTP server used for time synchronization.
[Time Zone]	[UTC -12:00] to [UTC +14:00]	–	Selects the time zone.

Color Video Camera
BRC-AM7

[Reset]

Initializes the unit.

[Reboot]

Reboots the unit.

Item	Sub-item setting	Factory default	Description
[Reboot]	[Execute]	–	<p>Reboots the unit. [Execute]: Execute function.</p> <p>Note</p> <ul style="list-style-type: none"> After rebooting, reload the page in the web browser.

[Reset]

Resets the settings of the unit.

Item	Sub-item setting	Factory default	Description
[All Reset (except for Network Settings)]	[Execute]	–	<p>Resets the settings of the unit (excluding the network settings). [Execute]: Execute function.</p> <p>Note</p> <ul style="list-style-type: none"> Imported base looks and LUT files are not deleted.
[Network Reset]	[Execute]	–	<p>Resets the network settings of the unit. [Execute]: Execute function.</p> <p>Note</p> <ul style="list-style-type: none"> After executing Network Reset, the unit will reboot. After rebooting, reload the page in the web browser.
[Factory Default]	[Execute]	–	<p>Returns the settings of the unit to the factory default state. [Execute]: Execute function.</p> <p>Note</p> <ul style="list-style-type: none"> Imported base looks and LUT files are deleted. After executing Factory Default, the unit will reboot. After rebooting, reload the page in the web browser.

Color Video Camera
BRC-AM7

[Information]

Displays camera information. Also used to update software.

[Camera]

Displays camera information and updates software.

Item	Sub-item setting	Factory default	Description
[Model Name]	–	–	Displays the model name of the camera.
[Serial Number]	–	–	Displays the serial number of the camera.
[Version Number]	–	–	Displays the software version of the camera.
[Version Up]	–	–	<p>Press the [Choose File] button and follow the on-screen instructions to update the camera software.</p> <p>Note</p> <ul style="list-style-type: none">After updating, the unit will reboot. After rebooting, reload the page in the web browser.

TP1001804694

Color Video Camera
BRC-AM7

[System Log]

Sets settings related to the system log.

Item	Sub-item setting	Factory default	Description
[Log Level]	[Critical, Warning & Info] / [Critical & Warning] / [Critical]	[Critical, Warning & Info]	Sets the level for adding a record to the system log.
[Log Size]	200 to 1024	1024	Sets the size of the log to save in the system log.
[Download as File]	–	–	Press the [Download] button and save the system log to a tablet or computer from the displayed screen.

The acquired log is displayed as shown below.

```
[INFO ] 2022-02-07 12:58:20 MODEL-NAME|9100030 Log configuration (level, size) has been changed. [Success]
[INFO ] 2022-02-07 12:58:48 MODEL-NAME|9100030 System started.
[INFO ] 2022-02-09 12:27:32 MODEL-NAME|9100030 System started.
[INFO ] 2022-02-09 12:28:56 MODEL-NAME|9100030 System started.
[INFO ] 2022-02-09 12:29:20 MODEL-NAME|9100030 Start firmware update sequence.
[WARNING ] 2022-02-09 12:29:20 MODEL-NAME|9100030 Entering external sync state.
[INFO ] 2022-02-09 12:40:47 MODEL-NAME|9100030 System rebooting.
[CRITICAL] 2022-02-09 12:54:11 MODEL-NAME|9100030 Camera block boot-up sequence failed.
[INFO ] 2022-02-09 12:54:18 MODEL-NAME|9100030 System started.
[INFO ] 2022-02-09 13:10:24 MODEL-NAME|9100030 System started.
[WARNING ] 2022-02-09 13:54:39 MODEL-NAME|9100030 Entering external sync state.
[INFO ] 2022-02-09 13:54:40 MODEL-NAME|9100030 It has turned into stand-by state.
[WARNING ] 2022-02-09 13:56:01 MODEL-NAME|9100030 Returned from external sync state.
[INFO ] 2022-02-09 13:56:08 MODEL-NAME|9100030 It has turned into power-on state.
[INFO ] 2022-02-15 09:46:50 MODEL-NAME|9100030 System started.
[INFO ] 2022-02-15 10:04:32 MODEL-NAME|9100030 System started.
[INFO ] 2022-02-15 10:05:52 MODEL-NAME|9100030 Start firmware update sequence.
[WARNING ] 2022-02-15 10:05:53 MODEL-NAME|9100030 Entering external sync state.
[INFO ] 2022-02-15 10:17:23 MODEL-NAME|9100030 System rebooting.
[INFO ] 2022-02-15 10:27:05 MODEL-NAME|9100030 System started.
[INFO ] 2022-02-15 10:34:01 MODEL-NAME|9100030 System started.
```

TP1001804695

Color Video Camera
BRC-AM7

[HTTP Access Log]

Sets settings related to the HTTP access log.

Item	Sub-item setting	Factory default	Description
[Log Level]	[Critical, Warning & Info] / [Critical & Warning] / [Critical]	[Critical, Warning & Info]	Sets the level for adding a record to the HTTP access log.
[Log Size]	200 to 1024	1024	Sets the size of the log to save in the HTTP access log.
[Download as File]	–	–	Press the [Download] button and save the HTTP access log to a tablet or computer from the displayed screen.

TP1001804696

[Service]

Obtains device information about the unit. Use when contacting your Sony service representative.

Item	Sub-item setting	Factory default	Description
[I agree to download device information.]	-	-	<p>Place a check mark here to agree to acquire device information, and press the [OK] button. Press the displayed [Download] button. The web browser will download a file named deviceinformation.dat momentarily.</p> <p>Note</p> <ul style="list-style-type: none"> After downloading, the unit will reboot. Reboot manually if the unit does not reboot automatically. After rebooting, reload the page in the web browser.

TP1001804697

Color Video Camera
BRC-AM7

[EULA]

Displays the End User License Agreement (EULA).

TP1001804698

Color Video Camera
BRC-AM7

[Software]

Displays the software license.

TP1001804699

5-065-326-11(1) Copyright 2024 Sony Corporation

Color Video Camera
BRC-AM7

Connecting External Monitors and Recording Devices

To display recorded/playback pictures on an external monitor, set the video output type for the external monitor and use an appropriate cable for the monitor to be connected.

You can also connect an external recorder and record the output signal from the unit.

You can display the same information that is visible in the camera image panel, such as status information and menus, on an external monitor. Set the desired system type for screen display to On using [Monitoring] – [Output Display] in the web menu.

Note

- If a monitor connected to the HDMI connector does not support the HDMI output format configured using the [Monitoring] menu in the web menu or camera menu, the camera image will not be output to the Web App. SDI2 or streaming video also cannot be output.
- You can set both [Output Display] – [SDI1] and [SDI2/HDMI/Stream] to [Off], but that will prevent use of the camera menu and functions that depend on the screen display. In addition, error notifications of the unit will be limited to the lamps (lit or blinking) of the unit and the display of the notification mark at the top right in the Web App. To see the detailed status, set [Output Display] to [On].

Hint

- [Output Display] – [SDI1] is set to [Off] and [SDI2/HDMI/Stream] is set to [On] by factory default. To use streaming as the main video, set [SDI] to [On] and [SDI2/HDMI/Stream] to [Off], and monitor the camera status on a monitor connected to SDI1.

SDI OUT connector (BNC type)

Set the output format using the [Monitoring] menu in the web menu or camera menu.

Use a commercially available 75 Ω coaxial cable for connection.

Note

- Check that the connection between the unit and the external device is grounded before turning the devices on.

It is recommended that the unit and external device be turned on after connecting the 75 Ω coaxial cable.

If the external device must be connected to the unit while the unit is on, connect the 75 Ω coaxial cable to the external device first and then connect it to the unit.

To start recording on the unit and external device simultaneously

With SDI signal output enabled, set [Project] – [SDI/HDMI Rec Control] – [Setting] to [SDI/HDMI Remote I/F] or [Parallel Rec] in the camera menu to enable output of a REC trigger signal to the external device connected to the SDI OUT 1 connector.

This will synchronize recording on the external device with the unit.

Note

- The SDI OUT 2 connector is not supported.
- If a connected external device does not support a REC trigger signal, the device cannot be operated.
- When [Project] – [SDI/HDMI Rec Control] – [Setting] is set to [SDI/HDMI Remote I/F] in the camera menu, only the REC trigger signal is output when there is no recording media currently inserted and the record START/STOP button is operated.

HDMI OUT connector (Type A connector)

Set the output On/Off setting and the output format in the [Monitoring] menu in the camera menu.

To start recording on the unit and external device simultaneously

With HDMI signal output enabled, set [TC/Media] – [HDMI TC Out] – [Setting] to [On] and [Project] – [SDI/HDMI Rec Control] – [Setting] to [SDI/HDMI Remote I/F] or [Parallel Rec] in the camera menu to enable output of a REC trigger signal to the external device connected to the HDMI OUT connector. This will synchronize recording on the external device with the unit.

Note

- If a connected external device does not support a REC trigger signal, the device cannot be operated.
- When [Project] – [SDI/HDMI Rec Control] – [Setting] is set to [SDI/HDMI Remote I/F] in the camera menu, only the REC trigger signal is output when there is no recording media currently inserted and the record START/STOP button is operated.

TP1001804700

5-065-326-11(1) Copyright 2024 Sony Corporation

Color Video Camera
BRC-AM7

Connecting with an RCP/MSU

Some of the functions of the unit can be controlled remotely by connecting a remote control panel (RCP) such as the RCP-3500/3501 or a master setup unit (MSU) such as the MSU-3500 to the unit via a LAN cable.

The connection method will vary depending on the configuration of related devices and the application.

- For details about a one-to-one connection between the unit and an RCP, see “One-to-One Connection Between the Unit and an RCP.”
 - For details about connecting multiple cameras using an MSU or camera control software, see “Using the Unit in a Multi Camera Environment with an MSU/Camera Remote Control Software.”
-

Related Topic

- [One-to-One Connection Between the Unit and an RCP](#)
- [Using the Unit in a Multi Camera Environment with an MSU/Camera Remote Control Software](#)

TP1001804701

Color Video Camera
BRC-AM7

One-to-One Connection Between the Unit and an RCP

Note

- Refer to “List of Supported Functions” and configure the unit so that it meets the operating conditions for the functions you want to use, then enable the connection with an RCP using the following procedure.

- 1 Turn each device on.
- 2 Set [Technical] – [RCP/MSU] – [CNS Mode] to [Bridge] in the web menu of the camera.
- 3 Configure the following settings on the RCP.
 1. Set the connection mode to Bridge mode.
 2. Register the IP address of the camera.For details about configuration, refer to the operating instructions of the RCP.

Related Topic

- [List of Supported Functions](#)

TP1001804702

Color Video Camera
BRC-AM7

Using the Unit in a Multi Camera Environment with an MSU/Camera Remote Control Software

You can connect multiple cameras using an MSU or camera remote control software.

Note

- Refer to “List of Supported Functions” and configure the unit so that it meets the operating conditions for the functions you want to use, then enable the connection with an MSU or camera remote control software using the following procedure.

1 Turn each device on.

2 Configure system network settings using the MSU or camera remote control software.

For details about configuration, refer to the operating instructions of the MSU or camera remote control software.

3 Configure the following settings using [Technical] – [RCP/MSU] in the web menu of the camera.

1. If using an MSU, set [CNS Mode] to [MCS]. If using camera remote control software, set [CNS Mode] to [PC Control].
2. Set the IP address of the master MSU or camera remote control software in [Master IP Address].
3. Set the camera number for which the camera will be registered in [Camera No.].

Related Topic

- [List of Supported Functions](#)

TP1001804703

List of Supported Functions

The following table shows the supported functions and their corresponding operating conditions.

Operation panel	Functions of the unit	Operating conditions
IRIS	Adjusting the iris manually	–
AUTO IRIS	Turning Auto Iris on/off	–
ND	Switching the ND filter preset position ([Clear] / [Preset1] to [Preset3])	This function is enabled when [Shooting] – [ND Filter] – [Mode] is set to [Preset] in the camera menu.
MASTER GAIN	Adjusting the gain manually (3 dB units)	Enabled when both the shooting mode is set to [Custom] mode and [Shooting] – [ISO/Gain] – [Mode] is set to [dB] in the camera menu. The display value of the dB value of the RCP/MSU is rounded to the closest 3 dB.
WHITE (R/B)	Adjusting the white balance ([R Gain] / [B Gain]) manually	Enabled when [White Mode] is set to [Memory A (R/B)] or [Memory A (T/T)].
WHITE (Color Temp)	Adjusting the white balance (color temperature/tint) manually <ul style="list-style-type: none"> ● RCP – [Color Temp]: White balance color temperature ● RCP – [Balance]: White balance tint value 	
ATW	Turning the ATW (Auto Tracing White Balance) function on/off	Enabled when the shooting mode is set to [Custom].
BLACK R/B	Adjusting the black balance	Enabled when the shooting mode is set to [Custom].

Operation panel	Functions of the unit	Operating conditions
MASTER BLACK	Adjusting the master black level	<ul style="list-style-type: none"> Enabled when the shooting mode is set to [Custom]. [H/V Ratio] and [Crispening] settings are enabled when [Paint/Look] – [Detail] – [Manual Setting] is set to [On] in the camera menu.
DETAIL	<ul style="list-style-type: none"> Turning the detail function on/off Setting the detail level Setting [H/V Ratio] Setting [Crispening] 	
User Matrix	<ul style="list-style-type: none"> Turning the user matrix correction function on/off Setting matrix correction values (R-G/R-B/G-R/G-B/B-R/B-G) 	
Multi Matrix	<ul style="list-style-type: none"> Turning the multi matrix correction function on/off Setting the hue and saturation of the color used for multi matrix correction Turning on/off the display function (Gate function) that distinguishes between the areas corresponding to the colors that are the target of multi matrix correction. <p>Note</p> <ul style="list-style-type: none"> Configurable only when the camera and RCP/MSU are connected in Bridge mode. 	
Knee	Turning the knee correction function on/off Turning the auto knee function on/off Setting the knee point and knee slope	
BARS	Turning color bars on/off <p>Note</p> <ul style="list-style-type: none"> Configurable only when the camera and RCP/MSU are connected in Bridge mode. 	
SHUTTER	<ul style="list-style-type: none"> Turning the shutter function on/off Setting the shutter speed value (Turning auto shutter on/off, setting angle shutter, setting slow shutter, and setting ECS not supported.) <p>Note</p> <ul style="list-style-type: none"> The RCP shutter settings may not be displayed depending on the configured shutter speed value. The RCP shutter settings may not be displayed correctly if the shutter cannot be operated from the RCP. 	<p>When auto shutter is on, auto shutter will continue to operate even if you turn the shutter on/off or change the shutter speed value from the RCP.</p> <p>When the shutter is set to [Angle], turning the shutter on/off or changing the shutter speed setting from the RCP is not supported.</p>

Note

- Configure the unit so that it meets the operating conditions for the functions you want to use, then enable the connection with an RCP/MSU. If the operating conditions are adjusted after the connection is enabled, unintended behavior may occur.

Color Video Camera
BRC-AM7

About Operation Using an RM-IP500 Remote Controller (option)

You can operate the unit using a Sony RM-IP500 Remote Controller running software version 2.5 or later. The communications method is VISCA (RS-422 standard) or VISCA over IP (LAN).

Depending on the target item to operate, you may need to view the screen display of the unit. Prepare a monitor that can be used to check the screen display.

The following operations are supported from an RM-IP500 Remote Controller.

- Selecting the target camera
- Adjusting the framing (pan, tilt, zoom)
- Adjusting the focus (excludes touch operation)
- Registering and recalling preset positions
- PTZ auto framing on/off, or resuming from pause
- Operating the menu of the unit (excluding the web menu)
- Adjusting the brightness
- Adjusting the white balance
- Adjusting the black balance
- Adjusting the audio input level
- Starting/stopping recording
- Executing assignable button functions of the unit

For details about RM-IP500 operation, refer to the operating instructions for the RM-IP500.

Hint

- When using an RM-IP500, use the panel sheet that is supplied with the RM-IP500.

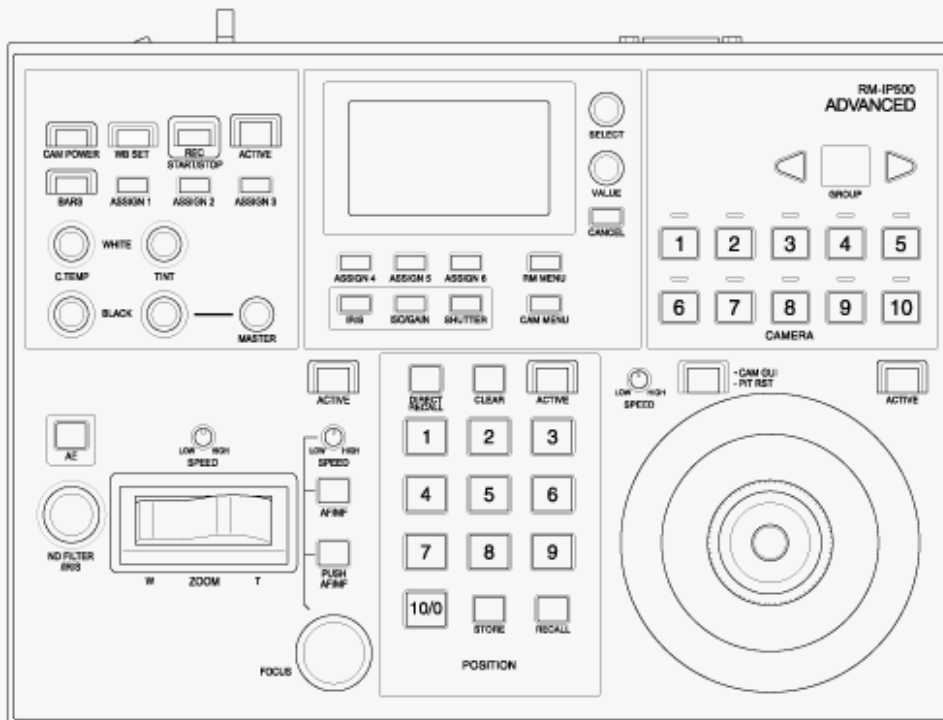

State when using a panel sheet

Color Video Camera
BRC-AM7

Connecting an RM-IP500 Remote Controller via Wired LAN

- 1 Set **SETUP** switch 4 of the unit to the **ON** position to enable **VISCA over IP** communication.

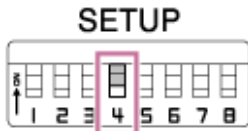

Note

- The switch setting is applied when the unit is next turned on.

- 2 Connect the **RM-IP500** to the same network as the unit.
- 3 Follow the procedure in the **RM-IP500** operating instructions to configure **VISCA over IP (LAN)** connection on the **RM-IP500**.

Assign this unit using RM menu > **AUTO IP SETUP** > **ASSIGN CAM**.

- 4 Assign functions of this unit to buttons and knobs, as required, using the following **RM** menu items of the **RM-IP500**.
SW ASSIGN
AE CONFIG2
WB MODE

- For details about assigning functions, refer to the operating instructions for the **RM-IP500**.
- For details about connecting via **VISCA (RS-422 standard)**, see "Connecting to the Unit using a Remote Controller (Option) via **RS-422**."

Related Topic

- [Connecting the Unit to a Network Device Via Wired Connection](#)
- [Connecting to the Unit using a Remote Controller \(Option\) via RS-422](#)

TP1001804706

Color Video Camera
BRC-AM7

About the Camera Remote SDK

The Camera Remote SDK (Software Development Kit) is a development environment provided for software developers to develop solutions and applications using Sony cameras. Using this SDK allows developers to remotely control Sony cameras from a host PC and to develop unique applications for shooting and image transfer. The SDK also provides many functions, such as changing camera settings, shutter release, live view monitoring, and more.

For details, visit the following web page.

<https://www.sony.net/CameraRemoteSDK/>

TP1001868329

Color Video Camera
BRC-AM7

About Synchronizing with an External Device

When shooting using multiple units, the units can be synchronized to a specific reference signal or timecode via the GENLOCK connector of the units.

- For details about genlock, see “Synchronizing the Phase of the Video Signal (Genlock).”
- For details about synchronizing timecodes, see “Locking the Timecode to Other Devices.”

Related Topic

- [Synchronizing the Phase of the Video Signal \(Genlock\)](#)
- [Locking the Timecode to Other Devices](#)

TP1001804707

Color Video Camera
BRC-AM7

Synchronizing the Phase of the Video Signal (Genlock)

You can supply a reference signal to the GENLOCK connector to enable genlock.

The input reference signals that can be used vary depending on the system frequency of the selected recording format.

System frequency of recording format	Supported input reference signals
119.88	1920×1080 59.94i 720×486 59.94i
100	1920×1080 50i 720×576 50i
59.94	1920×1080 59.94i 720×486 59.94i
50	1920×1080 50i 720×576 50i
29.97	1920×1080 59.94i 720×486 59.94i
25	1920×1080 50i 720×576 50i
23.98	1920×1080 23.98PsF 1920×1080 23.98P

You can check the external sync status using [Technical] – [Genlock] – [Reference] in the camera menu.

Note

- If the reference signal is unstable, genlock cannot be achieved.
- The subcarrier is not synchronized.

TP1001804708

Color Video Camera
BRC-AM7

Locking the Timecode to Other Devices

Set the unit that supplies the timecode to a mode in which the timecode output keeps running (such as Free Run or Clock).

1 Set the following in [TC/Media] – [Timecode] in the camera menu.

Set [Mode] to [Preset].
Set [Run] to [Free Run].

2 Press an assignable button assigned with the [DURATION/TC/U-BIT] function to display the timecode on the screen.

3 Supply an HD or SD reference video signal to the GENLOCK connector and the reference timecode to the TC IN connector.

The timecode generator of the unit acquires lock with the reference timecode, and “EXT-LK” appears on the screen. Once about ten seconds have elapsed after the timecode locks, the external lock state is maintained even if the external reference timecode source is disconnected.

Note

- Check that the supplied reference timecode and the reference video signal are in a phase relationship that complies with the SMPTE timecode standard.
- When operating with external lock, the timecode instantly acquires lock with the external timecode and the external timecode value appears in the time data display area. However, do not start recording immediately. Wait for a few seconds until the timecode generator stabilizes before recording.
- If the frequency of the reference video signal and the frame frequency on the unit are not the same, lock cannot be acquired and the unit will not operate properly. If this occurs, the timecode will not acquire successful lock with the external timecode.
- If the external timecode source is disconnected, the timecode may shift by one frame per hour with respect to the reference timecode.

To release external lock

Change the [TC/Media] – [Timecode] setting in the camera menu.

External synchronization is also released if the system frequency is changed and when you start recording in a special recording mode (Slow & Quick Motion).

TP1001804709

Connecting an External Microphone or External Audio Device

You can input the signal from an external microphone or external audio device and embed the audio in the recorded video or output video of the unit.

1 Connect an external microphone or external audio device using an XLR cable.

The unit has two XLR 3-pin female audio input connectors and one ø3.5 mm stereo mini jack MIC input connector.

- To use the AUDIO IN 1 connector, set [Audio] – [Audio Input] – [AUDIO IN 1 Select] in the web menu or camera menu. When connecting an external microphone, select [MIC] from the selection options. When connecting an external audio device, select [LINE].
- To use the AUDIO IN 2 connector, set [Audio] – [Audio Input] – [AUDIO IN 2 Select] in the web menu or camera menu. When connecting an external microphone, select [MIC] from the selection options. When connecting an external audio device, select [LINE].

2 Turn off the unit and connect the XLR cable to the AUDIO IN connector.

Simultaneously or alternatively, you can also connect a microphone with a ø3.5 mm stereo mini plug to the MIC connector.

3 Enable/disable the +48 V phantom power supply for the connected device using [Audio] – [Audio Input] in the web menu.

Configurable when [MIC] is selected in step 1.

- To enable the [AUDIO IN 1 Select] phantom power supply, set the [AUDIO IN 1 MIC +48V] switch to the on position. To disable, set to the off position.
- To enable the [AUDIO IN 2 Select] phantom power supply, set the [AUDIO IN 2 MIC +48V] switch to the on position. To disable, set to the off position.

Note

- Setting to [On] and connecting a device that is not compatible with a +48 V power supply may damage the connected device. Check the setting before connecting the device.

4 Set [Audio] – [Audio Input] – [CH1 Input Select] to [CH4 Input Select] in the web menu.

TP1001804710

Color Video Camera
BRC-AM7

Managing/Editing Clips Using a Computer

You can manage/edit clips using a computer.

Importing clips using a card reader (option)

Connect a CFexpress Type A card reader or SD card reader to your computer and use software that supports the recording format of this unit, such as Catalyst Browse, to import the clips.

Using a nonlinear editing system

In a nonlinear editing system, editing software (option) that supports the formats recorded by the unit is required.

TP1001804711

Color Video Camera
BRC-AM7

Outputting an Optical Fiber Signal

You can output an SDI signal converted to an optical signal by connecting an SFP+ module (option) to the OPTICAL connector of the unit. Use an SFP+ module that matches the signal band of each format.

Signal band

- 4K (59.94P, 50P): 12G
- 4K (other than 59.94P, 50P): 6G
- HD (59.94P, 50P): 3G
- HD (other than 59.94P, 50P): 1.5G

Note

- Use a module that complies with the following standards.
 - SFF standards
SFF-8083 / SFF-8418 / SFF-8419* / SFF-8432 / SFF-8433 / SFF-8071 / SFF-8472
* Power Level I (1.0 W)
 - SDI standards
ST297 / ST292 / ST424 / ST425 / ST2081 / ST2082
- The same signal as the SDI OUT 1 connector is output to the SFP+ module.
- The unit does not support optical fiber signal input.
- Use an SFP+ module for optical fiber signal output. For details about verified SFP+ modules, contact your dealer or Sony service representative.

TP1001804712

Connecting a Tally Signal

This topic describes tally signal control.

Lighting the tally lamp using a signal from a remote controller

You can light up the tally lamp using a VISCA over IP command from an external device, such as the RM-IP500. Set [Technical] – [Tally] – [Tally Control] to [External] in the web menu or camera menu.

Lighting the tally lamp from an external device

You can light up the tally lamp of the unit red or green from an external device, such as the RM-IP500 or a switcher. You can control the tally using commands transmitted over the network or using a tally signal input on the OPTION connector of the unit.

Set [Technical] – [Tally] – [Tally Control] to [External] in the web menu or camera menu.

When inputting a tally signal on the OPTION connector, short-circuit pin 7 to GND (either pin 4 or 5) to light up the tally lamp green, or pin 8 to GND (either pin 4 or 5) to light up the tally lamp red.

Note

- When [Tally Control] is set to [External], the recording status of the unit is not indicated by the tally lamp.
- When a red tally and green tally are input simultaneously, the tally lamp of the unit lights up red.

OPTION connector pin specifications

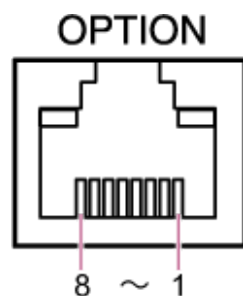

Pin No.	Signal direction	Signal specifications
1	–	Open
2	–	Open
3	OUT*1	<ul style="list-style-type: none"> ● Green tally lamp output ● Low-level output when green tally lamp is lit. ● Hi-Z (open-drain output) when green tally lamp is not lit.
4	–	GND (Ground)
5	–	GND (Ground)
6	OUT*1	<ul style="list-style-type: none"> ● Red tally lamp output ● Low-level output when red tally lamp is lit. ● Hi-Z (open-drain output) when red tally lamp is not lit.

Pin No.	Signal direction	Signal specifications
7	IN	Green tally external control input The tally of the unit is lit green when short-circuited to ground (either pin 4 or 5).
8	IN	Red tally external control input The tally of the unit is lit red when short-circuited to ground (either pin 4 or 5).

*1 The OUT output may not match the tally lamp.

Lighting the tally lamp of an external device using a signal from the unit

You can light up the tally lamp of an external device using a signal from the unit by connecting pin 3 and pin 6 of the OPTION connector as shown below.

OPTION connector pins 3 and 6 connection example

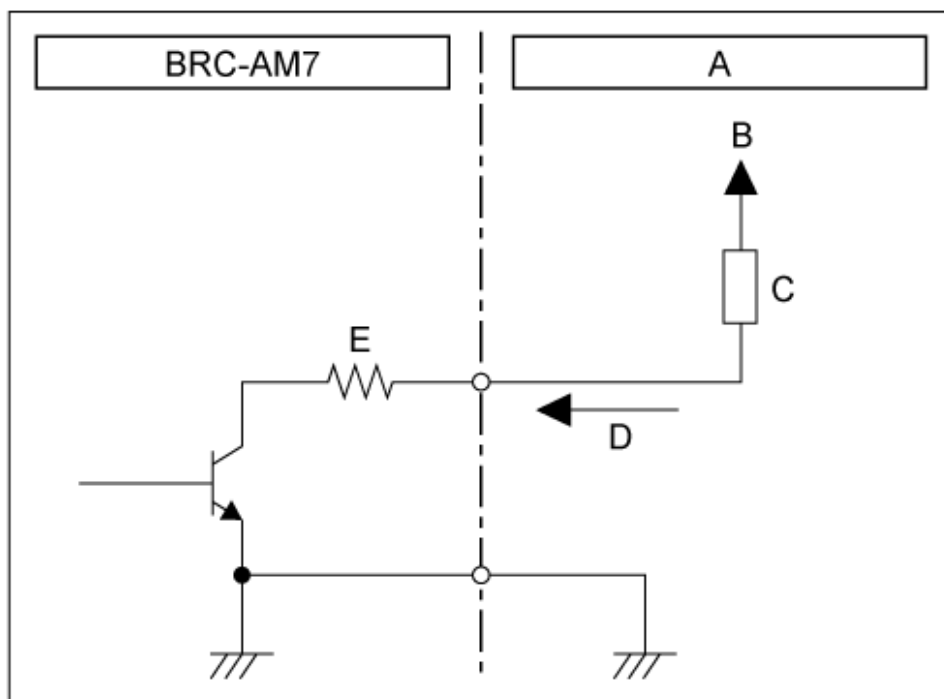

A: External device

B: Recommended voltage: 5 V (14 V max)

C: Load

D: Maximum load current: 100 mA

E: 4.7 Ω

Note

- Do not apply a voltage to pins 7 and 8.
- Do not connect an external device that can apply voltage to the OPTION connector.
- If an inrush or reverse voltage that exceeds the rating is applied to pin 3 or 6, it may cause a malfunction, smoke, or fire.
- Set the output signal using [Technical] – [Tally] – [Tally Control] in the web menu or camera menu.
 [Internal]: Recording operation status of the unit
 [External]: Logical-OR of red/green tally signals received by the unit via the IN signals and remote controllers.
 [PTZ AFR]: Not output.

TP1001804713

Color Video Camera
BRC-AM7

Outputting Tracking Data (free-d)

The unit can output pan/tilt/zoom, focus and iris tracking information synchronized to a sync signal.

The data output conforms to the free-d protocol, an industry standard. You can select the output method, choosing between constant output and output upon request from clients. Select the output method according to your VR/AR system.

1 Check that the unit is turned on.

2 Set the tracking data output method.

For constant output

1. Set [Technical] – [Tracking Data Output] – [Transfer Mode] to [Always] in the web menu.
2. Set the ID of the unit in [Camera ID].
3. Specify the output destination IP address in [Destination Address].
4. Specify the output destination port number in [Destination Port].
5. Press the [OK] button.

For output upon request from clients

1. Set [Technical] – [Tracking Data Output] – [Transfer Mode] to [On Demand] in the web menu.
2. Set the ID of the unit in [Camera ID].
3. Specify the port number for listening to requests from clients in [Listen Port].
4. Press the [OK] button.

Data output format

Hint

- Technical details are provided in the “free-d Integration Manual.” Contact a Sony sales representative.

The tracking data that is output by the unit comprises the following data according to the format specified in Type D0/D1 of the free-d protocol.

Type D0 – poll/command

Symbol	Content	Description
<D0>	Message type	
<CA>	Camera ID	
<CD>	command	Supports the following commands: <ul style="list-style-type: none"> ● 00 Stop stream mode ● 01 Start stream mode
<CK>	Checksum	

Type D1 – camera position/orientation data

Symbol	Content	Description
<D1>	Message type	
<CA>	Camera ID	
<PH><PM><PL>	Camera Pan Angle	Pan angle (-175° to 175°)
<TH><TM><TL>	Camera Tilt Angle	Tilt angle (-30° to 210°)
<RH><RM><TL>	Camera Roll Angle	Not supported (always 0)
<XH><XM><XL>	Camera X-Position	Not supported (always 0)
<YH><YM><YL>	Camera Y-Position	Not supported (always 0)
<HH><HM><HL>	Camera Height	Not supported (always 0)
<ZH><ZM><ZL>	Camera Zoom	Focal length
<FH><FM><FL>	Camera Focus	Focus distance
<SH><SL>	Spare/User Defined	Iris position
<CK>	Checksum	

Note

- Tracking data may be delayed or values may not be updated in the following situations:
 - When S&Q Motion is on
 - When displaying the camera menu
 - When displaying the thumbnail screen
 - When playing recorded clips
 - When displaying the web menu

TP1001804714

Color Video Camera
BRC-AM7

Usage Precautions

Privacy notification

The tracking function of the camera uses AI and facial recognition technology to automatically identify subjects and control the pan, tilt, and zoom functions to keep the subject in the image. This function processes facial “biometric” data of subjects selected as the tracking targets by the user. This recognition data is stored within the camera for a fixed interval and is not sent to Sony. No other captured skeletal or facial information is stored within the camera. This recognition data can be deleted by turning the camera off, putting it into standby state, or stopping the tracking function.

By using this camera function, you agree that you are responsible for the collection and use of images and data of subjects in accordance with applicable data protection laws. It is recommended that you inform subjects of the tracking and facial recognition technology used by this camera before shooting. If you have any queries, contact Sony Customer Support.

Usage notes

- When shooting using this camera, respect the privacy of others and comply with all local privacy laws, regulations, and moral standards for the locations where you are shooting.
- Do not use this camera for any illegal or improper purpose.
- Do not use this camera to defame, abuse, harass, stalk, threaten, or violate the legal rights of others, including rights of privacy and publicity.
- This camera is not intended for military or law enforcement applications.

Precautions when transporting and packing

Disconnect all connected cables and transport/package the unit in such a way that does not subject it to strong vibrations or shocks.

Condensation

If the unit is suddenly taken from a cold to a warm location, or if ambient temperature suddenly rises, moisture may form on the outer surface of the unit and/or inside of the unit. This is known as condensation. If condensation occurs, turn off the unit and wait until the condensation clears before operating the unit. Operating the unit while condensation is present may damage the unit.

Camera CMOS image sensor phenomena

Note

- The following phenomena that may occur in images are specific to image sensors. They do not indicate a malfunction.

- **White flecks**

Although the image sensors are produced with high-precision technologies, fine white flecks may be generated on the screen in rare cases, caused by cosmic rays, etc.

This is related to the principle of image sensors and is not a malfunction. Execute APR regularly.

The white flecks especially tend to be seen in the following cases:

- When operating at a high environmental temperature
- When you have raised the gain (sensitivity)

- **Flicker**

If shooting under lighting produced by fluorescent lights, sodium lamps, mercury-vapor lamps, or LEDs, the screen may flicker or colors may vary.

Lens and pan/tilt drive units

If the lens and pan/tilt drive mechanism is not operated for an extended period, the viscosity of the grease applied inside may increase, preventing the mechanism from moving. Operate the lens and pan/tilt mechanism regularly.

On consumable parts

- The fan and built-in rechargeable battery are consumable parts that will need periodic replacement. When operating at room temperature, a normal replacement cycle will be about 5 years. However, this replacement cycle represents only a general guideline and does not imply that the life expectancy of these parts is guaranteed. For details on parts replacement, contact your dealer.
- The life expectancy of the electrolytic capacitor is about 5 years under normal operating temperatures and normal usage (6 hours per day; every day). If usage exceeds the above normal usage frequency, the life expectancy may be reduced correspondingly.

Periodic inspections are recommended to keep the unit working properly and to prolong its usable lifetime. Contact a Sony service representative for more information about inspections.

About the built-in rechargeable battery

The unit has a built-in rechargeable battery for storing the date, time, and other settings even when the unit is turned off. The built-in rechargeable battery will be charged after 24 hours have elapsed if the unit is connected to a DC IN power supply or if the unit is powered via PoE++, regardless of whether the unit is turned on/off. The rechargeable battery will be fully discharged in about 1 month if the unit is not connected to a power supply. Use your unit after charging the battery. However, even if the rechargeable battery is not charged, the unit operation will not be affected as long as you do not need to record the date.

Usage and storage locations

Store in a level, ventilated place.

Avoid using or storing the unit in the following places.

- Locations exposed to rain or water (including under eaves)
- Outdoors and locations that exceed 40 °C (104 °F)
Remember that in summer in warm climates the temperature inside a car with the windows closed can easily exceed 50 °C (122 °F).
- Locations colder than 0 °C (32 °F).
- In damp or dusty locations. Locations where the unit may be exposed to rain
- Locations subject to vibration or shock
- Locations where radiation, X-rays, and strong magnetic fields are generated.
- Close to radio or TV transmitters producing strong electromagnetic fields.
- In direct sunlight or close to heaters for extended periods

Note on laser beams

Laser beams may damage the CMOS image sensor. If you shoot a scene that includes a laser beam, be careful not to let the laser beam be directed into the CMOS image sensor of the camera. Specifically, high-power laser beams from medical devices or other devices may cause damage due to reflected light and scattered light.

To prevent electromagnetic interference from portable communications devices

The use of portable telephones and other communications devices near this unit can result in malfunctions and interference with audio and video signals. It is recommended that the portable communications devices near this unit be powered off.

Do not place this product close to medical devices

This product (including accessories) has magnet(s) which may interfere with pacemakers, programmable shunt valves for hydrocephalus treatment, or other medical devices. Do not place this product close to persons who use such medical devices. Consult your doctor before using this product if you use any such medical device.

Security precautions

- SONY WILL NOT BE LIABLE FOR DAMAGES OF ANY KIND RESULTING FROM A FAILURE TO IMPLEMENT PROPER SECURITY MEASURES ON TRANSMISSION DEVICES, UNAVOIDABLE DATA LEAKS RESULTING FROM TRANSMISSION SPECIFICATIONS, OR SECURITY PROBLEMS OF ANY KIND.
- Depending on the operating environment, unauthorized third parties on the network may be able to access the unit. When connecting the unit to the network, be sure to confirm that the network is protected securely.
- From a safety standpoint, when using the unit connected with the network, it is strongly recommended to access the control window via a Web browser and change the access limitation settings from the factory preset values. Also, it is

recommended that you set a password with a sufficiently long character string that is hard to guess by others, and that you store it safely.

- When connecting this product to a network, connect via a system that provides a protection function, such as a router or firewall. If connected without such protection, security issues may occur.

Power supply

- The unit is not equipped with a power switch. To turn off the unit, check that all operations have ended and the unit is in power standby state, then disconnect the power cable. When using PoE++ power delivery, disconnect the LAN cable.
- Where possible, use a power source from a place where it is easy to insert and remove the power plug.
- If you use an outlet in a dusty place, clean the area around the outlet regularly to prevent tracking.
- Disconnect the power supply when not in use.

Precautions for moving parts

- Make sure that foreign matter does not enter moving parts.
- Do not apply an excessive load when moving parts by hand. Doing so may cause a malfunction.
- Do not interfere with the operation of moving parts during movement. Doing so may cause an injury or malfunction.
- Moving parts may not operate normally if the unit is not used for an extended period of time. Regularly operate the pan/tilt functions of the unit.

Precautions for continuous operation

- The unit can be powered 24 hours per day, 365 days per year (power standby state).
- Always perform a shooting test and verify that the unit operates normally.
 - Shooting continuously for periods in excess of 24 hours is not guaranteed.
 - If shooting for longer than 24 hours, place the unit in power standby state and then restart the unit.
- Note that Sony will not be liable for compensation of any kind for the content of images if you are unable to shoot due to any malfunction while using this unit.
- Always verify that the unit is operating properly before use. SONY WILL NOT BE LIABLE FOR DAMAGES OF ANY KIND INCLUDING, BUT NOT LIMITED TO, COMPENSATION OR REIMBURSEMENT ON ACCOUNT OF THE LOSS OF PRESENT OR PROSPECTIVE PROFITS DUE TO FAILURE OF THIS UNIT, EITHER DURING THE WARRANTY PERIOD OR AFTER EXPIRATION OF THE WARRANTY, OR FOR ANY OTHER REASON WHATSOEVER.
- SONY WILL NOT BE LIABLE FOR CLAIMS OF ANY KIND MADE BY USERS OF THIS UNIT OR MADE BY THIRD PARTIES.
- SONY WILL NOT BE LIABLE FOR THE TERMINATION OR DISCONTINUATION OF ANY SERVICES RELATED TO THIS UNIT THAT MAY RESULT DUE TO CIRCUMSTANCES OF ANY KIND.

Precautions for the recording function

- Always make a test recording, and verify that it was recorded successfully. SONY WILL NOT BE LIABLE FOR DAMAGES OF ANY KIND INCLUDING, BUT NOT LIMITED TO, COMPENSATION OR REIMBURSEMENT ON ACCOUNT OF FAILURE OF THIS UNIT OR ITS RECORDING MEDIA OR ANY OTHER MEDIA OR STORAGE SYSTEMS TO RECORD CONTENT OF ANY TYPE.
- Always verify that the unit is operating properly before use. SONY WILL NOT BE LIABLE FOR DAMAGES OF ANY KIND INCLUDING, BUT NOT LIMITED TO, COMPENSATION OR REIMBURSEMENT ON ACCOUNT OF THE LOSS OF PRESENT OR PROSPECTIVE PROFITS DUE TO FAILURE OF THIS UNIT, EITHER DURING THE WARRANTY PERIOD OR AFTER EXPIRATION OF THE WARRANTY, OR FOR ANY OTHER REASON WHATSOEVER.
- SONY WILL NOT BE LIABLE FOR CLAIMS OF ANY KIND MADE BY USERS OF THIS UNIT OR MADE BY THIRD PARTIES.
- SONY WILL NOT BE LIABLE FOR THE LOSS, REPAIR, OR REPRODUCTION OF ANY DATA RECORDED ON THE INTERNAL STORAGE SYSTEM, RECORDING MEDIA OR ANY OTHER MEDIA OR STORAGE SYSTEMS.
- SONY WILL NOT BE LIABLE FOR THE TERMINATION OR DISCONTINUATION OF ANY SERVICES RELATED TO THIS UNIT THAT MAY RESULT DUE TO CIRCUMSTANCES OF ANY KIND.

TP1001804715

Output Formats and Limitations

This topic describes the output formats and limitations.

Note

- The resolution of the output format is limited by the [Project] – [Rec Format] – [Frequency], [Codec], and [Video Format] settings in the web menu or camera menu.
- The resolution of the output format is also limited by the combination with the S&Q frame rate. In addition to the table of SDI OUT/HDMI OUT connector output formats below, the HDMI output changes to Full HD or lower when all the following conditions are met.
 - [Shooting] – [S&Q Motion] – [Setting] is set to [On]
 - [Shooting] – [S&Q Motion] – [Frame Rate] is higher than 60fps
- When the conditions above are met, 3840×2160P selection options are grayed out and cannot be selected.
- The image is not output if a higher resolution than the playback image resolution is configured.

SDI1/SDI2/HDMI OUT connector output formats

[Project] – [Rec Format]		[Monitoring] – [Output Format]		
[Frequency]	[Video Format]	[SDI1]	[SDI2]	[HDMI]
100/119.88Hz	3840×2160	3840×2160P	1920×1080P (Lvl A)	1920×1080P
		(Output stopped)	(Output stopped)	1920×1080i
		(Output stopped)	1920×1080P (Lvl A)	3840×2160P
		1920×1080P (Lvl A) (default value)	1920×1080P (Lvl A) (default value)	1920×1080P (default value)
		(Output stopped)	(Output stopped)	1920×1080i
		1920×1080P (Lvl B)	1920×1080P (Lvl A)	1920×1080P
	(Output stopped)	(Output stopped)	1920×1080i	
	1920×1080i	(Output stopped)	1920×1080i	
	1920×1080	1920×1080P (Lvl A) (default value)	1920×1080P (Lvl A) (default value)	1920×1080P (default value)
		(Output stopped)	(Output stopped)	1920×1080i
		1920×1080P (Lvl B)	1920×1080P (Lvl A)	1920×1080P
		(Output stopped)	(Output stopped)	1920×1080i
1920×1080i		(Output stopped)	1920×1080i	
(Output stopped)		(Output stopped)	1920×1080i	

[Project] – [Rec Format]		[Monitoring] – [Output Format]			
[Frequency]	[Video Format]	[SDI1]	[SDI2]	[HDMI]	
50/59.94Hz	3840×2160	3840×2160P	1920×1080P (Lvl A)	3840×2160P	
			1920×1080P (Lvl A)	1920×1080P	
			(Output stopped)	1920×1080i	
		1920×1080P (Lvl A) (default value)	1920×1080P (Lvl A) (default value)	1920×1080P (default value)	
			(Output stopped)	1920×1080i	
			1920×1080P (Lvl B)	1920×1080P	
	1920×1080	1920×1080P (Lvl A) (default value)	1920×1080P (Lvl A) (default value)	1920×1080P (default value)	
			(Output stopped)	1920×1080i	
		1920×1080P (Lvl B)	1920×1080P (Lvl A)	1920×1080P	
			(Output stopped)	1920×1080i	
	1920×1080i	(Output stopped)	1920×1080i		
	(Output stopped)	(Output stopped)	720×480P, 720×576P		
	25/29.97Hz	3840×2160	3840×2160P	1920×1080P	3840×2160P
				1920×1080P	1920×1080P
1920×1080P			1920×1080P	1920×1080P	
1920×1080		1920×1080PsF (default value)	–	1920×1080i (default value)	
		1920×1080P	1920×1080P	1920×1080P	
		1920×1080PsF (default value)	(Output stopped)	1920×1080i (default value)	
23.98Hz	3840×2160	3840×2160P	1920×1080P	3840×2160P	
			1920×1080P	1920×1080P	
		1920×1080P (default value)	1920×1080P (default value)	1920×1080P (default value)	
	1920×1080	1920×1080PsF	1920×1080P	1920×1080P	
		1920×1080P (default value)	1920×1080P (default value)	1920×1080P (default value)	
		1920×1080PsF	1920×1080P	1920×1080P	

Troubleshooting

Power supply

Symptom	Cause	Solution
Unit does not power on.	The power cable is not connected to the DC IN connector firmly.	Insert the power cable firmly as far as it will go.
	The power cable is not connected securely to a DC IN power supply or power outlet.	Insert the power cable firmly as far as it will go.
	The LAN cable is not connected firmly between the PoE++ power delivery device and the unit.	Check that the cable is inserted until it locks.
	The LAN cable is connected to the VISCA IN/OUT connector or OPTION connector, but not to the LAN connector.	Connect the LAN cable to the LAN connector correctly.
	The unit is connected to a power delivery device that does not support PoE++ (IEEE802.3bt, Type 4, Class 8 compliant).	Connect to a power delivery device that supports PoE++ (IEEE802.3bt, Type 4, Class 8 compliant).
	The total power consumption exceeds the maximum rating of the PoE++ power delivery device.	Refer to the operating instructions for the PoE++ power delivery device.
	A network cable with category rating that does not support PoE++ power delivery is connected.	Use a Category 5e or higher network cable connected to the LAN connector.
	The camera, PoE++ power delivery device, and peripheral devices are not connected to ground.	Connect the camera, PoE++ power delivery device, and peripheral devices to ground.

Image output

Symptom	Cause	Solution
No image is output.	Connected devices are not connected correctly.	Connect the connected devices correctly.
	Initial setup was not completed.	Complete the initial setup using the Web App.
No image is output from the HDMI connector.	A signal that is not supported by the HDMI output destination device is configured.	Change the HDMI output format setting or use a device that supports the output signal.
	A cable that does not support the output HDMI standard is being used.	Use a cable that supports the output HDMI standard in use.

Symptom	Cause	Solution
No image is output from the SDI connector.	A cable that does not support the output SDI standard is being used.	Use a cable that supports the output SDI standard in use.
	The monitor connected to the SDI connector does not support the output signal.	Use a monitor that supports the output SDI standard.
	A signal that is not supported by the HDMI output destination device is configured.	The SDI2 connector is affected by the HDMI output. Change the HDMI output format setting or use a device that supports the output signal.
	The HDMI output is set to SD resolution.	Set the HDMI output to a resolution other than SD.
No image is output from the optical fiber or the image is distorted.	The module being used does not comply with the SFF or SMPTE standards, or does not satisfy Power Level I (1.0 W).	See "Outputting an Optical Fiber Signal."
No image is output or is distorted when using external sync.	An external sync signal suitable for the configured video signal format is not being input.	Input an external sync signal suitable for the configured video signal format.
There is noise in the audio.	The camera, PoE++ power delivery device, and peripheral devices are not connected to ground.	Connect the unit, PoE++ power delivery device, and peripheral devices to ground.
	The unit is being used in an environment with devices that generate strong electric and magnetic fields (such as TV/radio transmitter antennas, amateur radio transmitters, air conditioner motors, power supply transformers).	Keep away from devices that generate strong electric and magnetic fields.
Camera menu does not appear when you press the [Menu] button.	The output system on which you want to display the camera menu is configured not to overlay the camera menu.	Set [Monitoring] – [Output Display] – [SDI1] or [SDI2/HDMI/Stream], whichever system you want to use, to [On].
	During PTZ auto framing, the camera menu cannot be embedded in the SDI2/HDMI output signal.	Set [Monitoring] – [Output Display] – [SDI1] to [On] in the web menu and use the SDI1 output signal.

Remote controller

Infrared remote control

Symptom	Cause	Solution
Infrared remote control does not function when pressed.	Infrared remote control operation is disabled.	Set [Technical] – [IR Remote] – [Setting] to [On] in the web menu.
	The ID of the infrared remote controller does not match the ID of the unit.	Set SETUP switches 1 and 2 on the connector block of the unit and the CAMERA SELECT switch of the infrared remote controller to the same setting.
	The battery has been discharged or the battery polarity is incorrect.	Operate the infrared remote control near the IR sensor of the unit. If the Power LED blinks, replace the battery.
	Initial setup was not completed.	Complete the initial setup using the Web App.
Operation targeted a camera other than the intended camera.	The infrared signal was received by a camera other than the intended camera.	Set [Technical] – [IR Remote] – [Setting] to [Off] in the web menu of the camera you do not want to control.
	The camera that you want to control and another camera are set with the same ID.	Change the setting of SETUP switches 1 and 2 on the connector block of the unit and the ID of the camera using the CAMERA SELECT switch of the infrared remote controller.

RM-IP500

Symptom	Cause	Solution
Camera cannot be operated from the RM-IP500 Remote Controller.	The power supply for the camera is not connected.	Check that the POWER lamp of the unit lights up green or orange.
	The camera or remote controller is not connected to the network.	Check the unit and remote controller connections.
	Initial setup of the camera was not completed.	Complete the initial setup using the Web App.
	VISCA (RS-422 standard) or VISCA over IP communication is not enabled.	Set SETUP switch 4 to the ON position on the connector panel of the unit and reboot the unit.
	The RM-IP500 is configured differently from the connection method.	Refer to the RM-IP500 instruction manual for instructions on how to switch between VISCA RS-422 (serial) connection and LAN connection.
	The IP address of the camera changed.	Check the IP address of the camera using [Network] – [Wired LAN] in the web menu or camera menu.
The IP address of the camera was changed using AUTO IP SETUP on the RM-IP500 Remote Controller.	At least 20 minutes has elapsed since the camera was started.	Reboot the unit. The IP address can be changed using AUTO IP SETUP within the first 20 minutes after starting the unit.

Web App

Symptom	Cause	Solution	
Cannot connect using a web browser.	A category 5e or higher LAN cable is not connected.	Connect a Category 5e or higher LAN cable.	
	Not connected to LAN correctly or connected network is not operating normally.	Check that the Link LED for the LAN connector is lit. If the Link LED is not lit, contact your network administrator.	
	The power supply for the camera is not connected.	See "Unit does not power on" in the "Power supply" section above.	
	A valid IP address is not configured for the unit.		Perform a network reset. <ul style="list-style-type: none"> For details about resetting network settings, see "Resetting Unit Settings."
			Set the unit to fixed IP address mode and connect it directly to a computer set to 192.160.0.200 or other unique address. Specify 192.160.0.100 in a web browser to open the Web App. <ul style="list-style-type: none"> For details, see "Connecting the Unit to a Network Device Via Wired Connection."
	The configured IP address is in use on another device.		Check that the IP addresses of peripheral devices are unique.
			First, connect the unit directly to a computer on which a web browser is open, and then start the unit in fixed IP address mode. <ul style="list-style-type: none"> For details, see "Connecting the Unit to a Network Device Via Wired Connection."
	An IP address conflict occurred because a device configured to fixed IP address mode was connected to the same network.		Set SETUP switch 8 (fixed IP address mode) to the OFF position on the unit and reboot the unit.
	The configured subnet mask does not match the used network subnet.		Perform a network reset. <ul style="list-style-type: none"> For details about resetting network settings, see "Resetting Unit Settings."
	The unit is being accessed on the same local network via a proxy server.		Change the configuration so that a proxy server is not used.
The configured default gateway for the unit is incorrect.		Perform a network reset. <ul style="list-style-type: none"> For details about resetting network settings, see "Resetting Unit Settings." 	
The entered URL is incorrect.		Enter the correct URL and try again. <ul style="list-style-type: none"> For the URL of the Web App, see "Accessing the Web App from a Web Browser." 	

Symptom	Cause	Solution
	The HTTP port is incorrect.	Display the camera menu on an external monitor and check the setting of [Network] – [Wired LAN] – [HTTP Port]. If a value other than 80 is configured, add the HTTP port number to the host name or IP address entered in the web browser. Example: If HTTP Port is set to 8080, enter http://<IP Address>:8080
	The HTTP port number of the unit is being filtered or blocked.	Change the HTTP port number of the unit to a port that is not being filtered or blocked.
	Old cache of the web browser is having an adverse effect.	Delete the cache from the web browser.
Cannot connect to the Web App using the 2D code (QR code).	The device being used does not support mDNS.	Use a device that supports mDNS. If using a device that does not support mDNS, enter the IP address directly into the web browser.
	The tablet or computer is connected to a different network than the camera.	Connect the tablet or computer to the same local network as the unit.
Cannot connect to the Web App by manually entering the URL.	The device being used does not support mDNS.	Use a device that supports mDNS.
	The tablet or computer is connected to a different network than the camera.	Connect the tablet or computer to the same local network as the unit.
The authentication screen is displayed continuously.	The correct user name or password was not entered.	Enter the registered user name and password. If you have forgotten the registered user information, see “RESET switch” in “Connector Block” to initialize the user information for network connection.
	The user name and password were changed by a user logged in using another web browser.	Check the correct user name and password with the unit administrator.
Camera image is not displayed in the Web App.	The HDMI output of the camera is set to 720×480 or 720×576.	Change the resolution of the HDMI output of the unit.
	An HDMI monitor that does not support the HDMI output signal of the camera is connected.	Remove the HDMI monitor or use an HDMI monitor that supports the HDMI output settings.
	The unit was rebooted and the session was disconnected.	Wait about one minute and reload the web browser.
	Old cache of the web browser is having an adverse effect.	Delete the cache from the web browser.
Resolution of the camera image displayed in the Web App is low.	The resolution for video stream 3 used by the Web App is set low.	Increase the value using [Stream] – [Video Stream] – [Size 3] in the web menu.

Symptom	Cause	Solution
Camera menu does not appear when you press the [Menu] button.	The camera menu is configured so that it is not being embedded in the SDI2/HDMI output signal.	Set [Monitoring] – [Output Display] – [SDI2/HDMI/Stream] to [On] in the web menu.
Value of a setting on the settings screen is not updated/displayed properly.	The settings screen of the Web App does not automatically reflect the settings changed in another Web App.	Press the [Reload] button at the bottom of the settings screen of the Web App. The values of the settings on the displayed setup screen are reloaded and updated.
	The settings of temporary Internet files are having an affect.	Delete the cache from the web browser.
Cannot download configuration file or log.	The download file function of the web browser is disabled.	Enable the download file function of the web browser.
Settings screen of the Web App is accessible, but cannot perform operations on the live operation screen and playback operation screen.	The Web App operation screen is locked.	Set the operation lock switch at the top right in the Web App to the  (Operation Unlock) position.
Web App screen takes some time to display.	The streaming image of the unit is being viewed by multiple users simultaneously.	Reduce the number of users that can access the Web App simultaneously.
Image is distorted or jerky.	The video information is not transmitted properly due to congestion in the communications path.	Reduce the streaming bit rate, set [Video Stream 3] – [Size] to the smallest option, or reduce the frame rate to create a margin in the communications band.
	Multiple web browsers are running on the tablet and are occupying memory.	Close any web browsers that are running in the background.
	Too many web browser tabs are open, slowing down operation.	Close any tabs not being used.
	Excessive accumulation of web browser cache and browsing history is slowing down operation.	Delete the cache of the web browser.

Shooting

Pan/tilt

Symptom	Cause	Solution
Camera does not stop in the expected position.	Cannot execute pan/tilt reset.	Execute a pan/tilt reset as described in “Resetting the Pan/Tilt.”
	An unexpected force was applied to the camera head, causing a pan/tilt control error.	

Symptom	Cause	Solution
Camera does not return to the front when the  (Pan/tilt home) button is pressed.	Ceiling mount setting has been activated.	Set [Pan-Tilt] – [P/T Direction] – [Ceiling] in the web menu according to the actual installation, and then turn the unit on again. When mounted on a ceiling, the connector block will be at the front of the camera.
Pan/tilt operation is restricted.	Pan/tilt range limit is configured.	Clear the pan/tilt range limit settings, as required, as described in “P/T Range Limit.”
	A pan/tilt error occurred.	Execute a pan/tilt reset as described in “Resetting the Pan/Tilt.”
Pan/tilt operation moved in the opposite direction.	The ceiling mount setting is different than the actual mounting state.	Set [Pan-Tilt] – [P/T Direction] – [Ceiling] in the web menu according to the actual installation.
	Settings related to the pan/tilt direction were changed.	Check the [Pan-Tilt] – [P/T Direction] setting in the web menu.
Image does not move smoothly at the start and end of pan/tilt operation.	The pan/tilt operation acceleration/deceleration setting is too high.	Reduce the pan/tilt operation acceleration/deceleration setting to make the motion at the start and end of pan/tilt operation smoother using [Pan-Tilt] – [P/T Acceleration] – [Ramp Curve] in the web menu or camera menu. Note that this will mean that the lens takes longer to reach the maximum speed.
Cannot save a preset position.	A preset cannot be saved if Clear Image Zoom is operating.	Set the Clear Image Zoom ratio back to 1×. (state where the ratio is not displayed on the right of  (Zoom ratio))
Framing is offset when playing back a preset position.	The temperature of the environment may have changed significantly between when a preset position was saved and when it is played back.	Save the preset position again.
The framing control panel of the Web App is grayed out and cannot be operated.	The pan/tilt operation is unavailable while the thumbnail screen is displayed and during playback.	Display the playback control screen and exit the thumbnail screen display or stop playback.
	The pan/tilt operation is unavailable when the camera image cannot be displayed in the Web App.	See “Web App” in “Troubleshooting.”
“Execute Pan-Tilt Reset” is displayed below the framing control panel in the Web App.	A pan/tilt error occurred.	Execute a pan/tilt reset as described in “Resetting the Pan/Tilt.”

Recording/playback

Symptom	Cause	Solution
Recording does not start when you press the record START/STOP button.	The memory card is full.	Replace the memory card with one having sufficient space.
	The memory card needs restoration.	Restore the memory card as described in "Restoring Memory Cards."
	The recording/tally lamp is configured as a tally lamp, so the recording status cannot be determined by the lamp.	Configure the recording/tally lamp to function as a recording lamp as described in "Connecting a Tally Signal."
	PoE++ power supply is in use.	Supply power from the DC IN connector.
Audio recording is not possible.	A microphone is not connected.	Connect a microphone or audio device to the AUDIO IN 1, AUDIO IN 2, or MIC connector on the connector block.
	The [Master Input Level] setting is at the minimum value.	Adjust [Master Input Level].
Recorded sound is distorted.	The audio input level setting is too high.	Adjust [CH1 Input Level] to [CH4 Input Level] and [Master Input Level].
		When using a microphone in a loud environment, such as a live music venue, first adjust [AUDIO IN 1 MIC Ref.] and [AUDIO IN 2 MIC Ref.].
Recorded sound has a high noise level.	The audio input level setting is too low.	Adjust [Audio Input Level] and [Audio] – [Audio] – [Audio Input] – [AUDIO IN 1 MIC Ref.] or [AUDIO IN 2 MIC Ref.] settings.
Clips cannot be played back.	The clip is being edited.	Clips cannot be played back if you have modified file names or folders, or if the clip is in use on a computer. This is not a malfunction.
	The clip was recorded using a camera other than this unit.	Clips recorded using a camera other than this unit may not be played back, or displayed in incorrect size. This is not a malfunction.

File transfer

Symptom	Cause	Solution
File uploading fails.	The user name and password on the server are not correct.	The user name and password on the server may not be correct. Enter the correct entries.

IP streaming

Symptom	Cause	Solution
Streaming not available.	The user name or password entered in the client application to view streaming from the unit is incorrect.	If the streaming format of the unit is set to [RTSP], [SRT-Listener], or [NDI HX], it is necessary to enter the user name and password set for this unit in the client application. Enter the correct user name and password.
	The streaming protocol is not set.	Select the target protocol using [Stream] – [Stream Setting] in the web menu.
	Six or more RTSP sessions have been set.	Set the number of sessions to five or fewer.
	UDP port number is not set correctly.	Check the port number and other settings for the target protocol using [Stream] – [Stream] – [Stream Setting] in the web menu.
	UDP communication is blocked.	Check the security software settings.
Audio is not being streamed.	Audio output streaming is set to [Off].	Set [Stream] – [Audio Stream] – [Setting] to [On] in the web menu.
Streaming was disconnected.	The protocol setting or streaming codec settings were changed during streaming.	Set the protocol setting and streaming codec settings before starting streaming.
Picture size of [Video Stream 1] cannot be set to 3840×2160.	The picture size is 1920×1080 when [Output Format] is set to HDMI.	The picture size for streaming cannot be set higher than the HDMI picture size. Change the HDMI picture size using [Monitoring] – [Output Format] in the web menu.
Frame rate of [Video Stream 1] cannot be set to 60fps or 50fps.	The streaming frame rate is set to 29.97 or lower.	The frame rate used for streaming is limited by the system frequency. Change the system frequency using [Rec Format] – [Frequency] in the web menu.
[Video Stream 3] stream cannot be accessed.	[Video Stream 3] does not support RTSP/SRT/NDI.	Use [Video Stream 1] or [Video Stream 2].
RTSP/SRT screen is not updated/displayed properly.	The port number used for RTSP or SRT is being filtered or blocked.	Change the RTSP or SRT port number to a port that is not being filtered or blocked by devices receiving the stream. Or change the port number used for RTSP or SRT on the unit.
Image is distorted or jerky.	The video information is not transmitted properly due to congestion in the communications path.	Reduce the streaming bit rate or set the [Video Stream 2] codec ([Codec 2]) to [Off] to create a margin in the communications band.
	The order of video packets has changed within the communications channel.	Use the same Internet service provider on both the unit side and the receiver side.
Not detected as NDI device.	The streaming protocol is not set to NDI HX.	The streaming protocol must be set to NDI HX in order to detect the unit as an NDI device. Set [Stream] – [Stream Setting] to [NDI HX] in the web menu.

Connection with external devices

External synchronization

Symptom	Cause	Solution
Cannot synchronize to external source.	An external sync signal suitable for the configured video signal format is not being input.	Input an external sync signal suitable for the configured video signal format.
	Unit is double-terminated.	The unit has a built-in 75 Ω terminator. Connect directly to a signal source (one-to-one) or use a distributor (splitter).

Tally

Symptom	Cause	Solution
Tally lamp does not light up.	The tally lamp brightness is set to Off.	Set the appropriate brightness using [Technical] – [Tally] – [Tally Lamp Brightness] in the web menu.
	The recording/tally lamp is configured as a recording lamp or PTZ AFR indicator.	Configure the recording/tally lamp to function as a tally lamp as described in “Connecting a Tally Signal.”
	RM-IP500 is connected and VISCA over IP is disabled.	Set SETUP switch 4 to the ON position on the connector block of the unit.
	The OPTION connector connection is incorrect or the target pin is not short-circuited to GND.	Short-circuit pin 7 or pin 8 of the OPTION connector to GND as described in “Connecting a Tally Signal.”

Related Topic

- [Resetting Unit Settings](#)
- [Connecting the Unit to a Network Device Via Wired Connection](#)
- [Accessing the Web App from a Web Browser](#)
- [Outputting an Optical Fiber Signal](#)
- [Connector Block](#)
- [Resetting the Pan/Tilt](#)
- [\[P/T Range Limit\]](#)
- [Restoring Memory Cards](#)
- [Connecting a Tally Signal](#)

TP1001804717

Error/Warning Messages

If a warning, caution, or operating condition that requires confirmation occurs on the unit, a message is displayed in the camera image panel, and the POWER lamp and NETWORK lamp on the front panel and the recording/tally lamp start blinking.

Note

- The recording/tally lamp blinking indication is enabled only when both [Technical] – [Tally] – [Tally Control] is set to [Internal] and [Tally Lamp Brightness] is not set to [Off] in the web menu or camera menu.

Error messages

If the POWER lamp and NETWORK lamp are blinking as described below, take the following measures.

POWER lamp	NETWORK lamp	Cause and solution
Blinking orange slowly	Blinking green slowly	The unit cannot operate normally. For details, see [Maintenance] – [System Log] in the web menu. If the problem persists even after putting the unit in standby mode or turning the power off and then on again, contact your Sony service representative.
Blinking orange rapidly	Blinking green rapidly	A malfunction occurred on the unit. Contact your Sony service representative.

The unit will stop operation when the following display occurs.

Message display	Recording/tally lamp	Cause and solution
E + error code	High-speed blinking	Indicates an abnormality in the unit. Recording stops, even if ●REC is displayed in the camera image panel. Turn off the unit, and check for any problem with connected devices, cables, or media. If the error persists when the unit is turned on again, contact your Sony service representative. An error display or warning sound may not occur depending on the status of the unit.

Warning messages

Follow the instructions provided if the following display occurs.

Message display	Recording/tally lamp	Cause and solution
[Temperature High]	Blinking	The internal temperature is high. Turn off the unit and allow it to cool down before operating it again.
[Media Temperature High]	Blinking	The temperature of the CFexpress card is high. Replace the card or allow it to cool down before using it again.

Message display	Recording/tally lamp	Cause and solution
[Voltage Low]	Blinking	The DC IN voltage is low (level 1). Check the power source.
[Pan-Tilt has overloaded.]	Blinking	The pan/tilt mechanism is overloaded. Check the unit to make sure there are no obstacles or other issues.
[Insufficient Voltage]	High-speed blinking	The DC IN voltage is too low (level 2). Media recording/playback, PTZ auto framing, pan/tilt operation stops and is unavailable. Turn off the power, and increase the power supply voltage or use a shorter cable, and reconnect the power. ¹⁾
[Media Near Full]	Blinking	The remaining capacity on the memory card is getting low. Replace at the earliest convenience.
[Media Full]	High-speed blinking	Clips could not be recorded or copied because there is no remaining capacity on the memory card. Replace immediately.
[Clips Near Full]	Blinking	The number of additional clips that can be recorded on a memory card is getting low. Replace at the earliest convenience.
[Clips Full]	High-speed blinking	The maximum number of clips that can be recorded on the memory card has been reached. Recording or copying more clips is not possible. Replace immediately.
[Last Clip Recording]	Blinking	The clip currently recording is the last clip that can be recorded, as the maximum number of clips has been reached. Prepare a new memory card.
[Media(A) Life Near End] ²⁾	Blinking	The memory card is approaching the end of its life. Replace at the earliest convenience.
[Media(A) Life End] ²⁾	High-speed blinking	The memory card has reached the end of its life. Replace immediately.
[Media(A) Near Full] ²⁾	Blinking	When using the Simul Rec function
[Media(A) Full] ²⁾	High-speed blinking	When using the Simul Rec function
[Media(A) Clips Near Full] ²⁾	Blinking	When using the Simul Rec function
[Media(A) Clips Full] ²⁾	High-speed blinking	When using the Simul Rec function
[Media(A) Last Clip Rec] ²⁾	Blinking	When using the Simul Rec function

1) The displayed DC IN voltage value indicates the voltage at the connector block. The voltage may temporarily drop due to large load fluctuations. If the voltage value varies significantly from the power supply voltage, use a shorter, thicker cable or increase the power supply voltage.

2) "(B)" is displayed for the card in slot B.

Caution and operation messages

The following caution and operation messages may appear in the center of the screen. Follow the instructions provided to resolve the issue.

Display message	Cause and solution
[Backup Battery End] [Please Change]	The remaining capacity of the backup battery is insufficient. Connect the unit to a power supply for at least 24 hours to charge the backup battery.
[Unknown Media(A)] ¹⁾ [Please Change]	A memory card that has been partitioned or a memory card containing more clips that can be handled by the unit was inserted. The card cannot be used in the unit, and must be replaced.
[Cannot Use Media(A)] ¹⁾ [Unsupported File System]	A card using a different file system or an unformatted card was inserted. The card cannot be used in the unit, and must be replaced or formatted using the unit.
[Media Error] [Media(A) Needs to be Restored] ¹⁾	An error occurred on the memory card, and the card must be restored. Restore the memory card.
[Media Error] [Cannot Record to Media(A)] ¹⁾	The memory card may be damaged, and can no longer be used for recording. Playback is possible, so making a copy and replacing the memory card is recommended.
[Media Error] [Cannot Use Media(A)] ¹⁾	The memory card may be damaged, and can no longer be used for recording or playback. The card cannot be used in the unit, and must be replaced.
[Media(A) Error] ¹⁾ [Recording Halted] [Playback Halted]	Recording and playback was stopped because an error occurred while using the memory card. If the problem persists, replace the memory card.
[Media Reached Rewriting Limit] [Change Media(A)] ¹⁾	The memory card has reached the end of its life. Make a backup, and replace the card immediately. If you continue using the card, the card may not be able to record or play. For details, refer to the operating instructions for the memory card.
[The specified address is invalid.]	The specified address is invalid. Check that the setting is correct.
[Cannot Use Specified Port Number]	The specified port number is invalid. Check that the setting is correct.
[Cannot add auto upload job of Proxy file because maximum number of upload jobs was reached.]	The maximum number of transfer jobs has been reached. Clear any unwanted jobs. The auto upload destination setting for proxy files may also be incorrect. Check that the setting is correct.
[Fan Stopped]	Fan has stopped running. Check that there is no dust or foreign matter. If the error persists after removing any dust or foreign matter, contact your Sony service representative.

1) "(B)" is displayed for the card in slot B.

RTMP streaming error information

The following error information may be displayed on the unit. Perform the following actions, as required.

Error code		Description	Solution
RTMP	RTMPS		
1002 1004	2002 2004	Cannot connect to RTMP server.	Check that the server URL setting is correct. Check the network connection.
1003	2003	Cannot resolve the domain name.	Check that the server URL setting is correct. Check the DNS server connection.
–	2005 2008	CRL error	Check that the server URL setting is correct. Check that the connection destination is a trusted site.
	2006	CA certificate error	Check that the clock setting is correct. Check that the CA certificate is correct.
–	2007	A CA certificate is not installed. Server certificate authentication error.	Install an CA certificate. Check that the connection destination is a trusted site.
4002		RTMP session was disconnected.	The unit may have been disconnected on the RTMP server side. Check that the settings match the recommended codec parameter of the service.
4003		The network connection quality is low.	Check the network connection.
Other		Other errors.	

SRT streaming error information

The following error information may be displayed on the unit. Perform the following actions, as required.

Error code	Description	Solution
SRT-Caller		
1001	Unexpected error	The unit may not be operating normally. Power cycle the unit.
1002	Communication disconnected due to change in settings	Communication was disconnected because the settings were changed. Re-establish the connection.
5001	Unexpected error	The unit may not be operating normally. Power cycle the unit.
5005	Connection failure	Check that the connection destination setting is correct.
5006	Encryption error	Check that the encryption setting is correct.
5007	Unexpected error	The unit may not be operating normally. Power cycle the unit.
5008	Unexpected error	
5009	Transmission failure	The unit was disconnected during communication. Check the network connection.

Color Video Camera
BRC-AM7

List of Menu Items

The following tables list the menu items of the unit.

Legend

- “Camera menu” and “web menu”
 - : Available
 - ▲: Some items available
 - : Not available

- “All File” and “Scene File”
 - Yes: Item saved in an ALL file or scene file
 - No: Item not saved

- “All Reset (except for Network Settings)”
 - When [Reset] – [Reset] – [All Reset (except for Network Settings)] in the web menu is executed
 - Yes: Initialized item (excludes network settings)
 - No: Not applicable

- “Network Reset”
 - When [Reset] – [Reset] – [Network Reset] in the web menu is executed
 - Yes: Initialized item (network setting)
 - No: Not applicable

- “Factory Default”
 - Yes: Item reset to factory default
 - No: Not applicable

[Shooting]

Item (level 2)	Camera menu	Web menu	All File	Scene File	All Reset (except for Network Settings)	Network Reset	Factory Default
[ISO/Gain]	●	–	Yes	No	Yes	Yes	Yes
[ND Filter]	●	–	Yes	No	Yes	No	Yes
[Shutter]	●	–	Yes	No	Yes	No	Yes
[Auto Exposure]	●	–	Yes	No	Yes	No	Yes
[White]	●	–	Yes	No	Yes	No	Yes
[White Setting]	●	–	Yes	No	Yes	No	Yes
[Offset White]	●	–	Yes	No	Yes	No	Yes
[Focus]	●	▲	Yes	No	Yes	No	Yes
[S&Q Motion]	●	–	Yes	No	Yes	No	Yes
[LUT On/Off]	●	–	Yes	No	Yes	No	Yes
[NIGHTSHOT]	●	–	Yes	No	Yes	No	Yes

Item (level 2)	Camera menu	Web menu	All File	Scene File	All Reset (except for Network Settings)	Network Reset	Factory Default
[Noise Suppression]	●	–	Yes	No	Yes	No	Yes
[Flicker Reduce]	●	–	Yes	No	Yes	No	Yes

[Project]

Item (level 2)	Camera menu	Web menu	All File	Scene File	All Reset (except for Network Settings)	Network Reset	Factory Default
[Base Setting]	●	●	Yes	No	Yes	No	Yes
[Rec Format]	●	●	Yes	No	Yes ^{*1}	No	Yes
[Flexible ISO Setting]	●	–	Yes	No	Yes	No	Yes
[Simul Rec]	●	●	Yes	No	Yes	No	Yes
[Proxy Rec]	●	▲	Yes	No	Yes	No	Yes
[SDI/HDMI Rec Control]	●	–	Yes	No	Yes	No	Yes
[Assignable Button]	●	–	Yes	No	Yes	No	Yes
[All File]	–	●	No	No	No	No	No

*1 [Frequency] not applicable

[Paint/Look]

Item (level 2)	Camera menu	Web menu	All File	Scene File	All Reset (except for Network Settings)	Network Reset	Factory Default
[Scene File]	●	–	No	No	No	No	No
[Base Look]	●	▲	Yes ^{*1}	No	Yes ^{*1}	No	Yes ^{*1}
[Reset Paint Settings]	●	–	No	No	No	No	No
[Black]	●	–	Yes	Yes	Yes	No	Yes
[Knee]	●	–	Yes	Yes	Yes	No	Yes
[Detail]	●	–	Yes	Yes	Yes	No	Yes
[Matrix]	●	–	Yes	Yes	Yes	No	Yes
[Multi Matrix]	●	–	Yes ^{*2}	Yes ^{*2}	Yes	No	Yes

*1 LUT data imported as base look not applicable

*2 [Axis] not applicable

[Pan-Tilt]

Item (level 2)	Camera menu	Web menu	All File	Scene File	All Reset (except for Network Settings)	Network Reset	Factory Default
[P/T Speed]	–	●	No	No	Yes	No	Yes
[P/T Acceleration]	●	●	No	No	Yes	No	Yes
[P/T Range Limit]	–	●	No	No	Yes	No	Yes
[P/T Direction]	–	●	No	No	Yes	No	Yes
[P/T Preset]	–	●	No	No	Yes	No	Yes

[TC/Media]

Item (level 2)	Camera menu	Web menu	All File	Scene File	All Reset (except for Network Settings)	Network Reset	Factory Default
[Timecode]	●	–	Yes ^{*1}	No	Yes	No	Yes
[TC Display]	●	–	Yes	No	Yes	No	Yes
[Users Bit]	●	–	Yes ^{*1}	No	Yes	No	Yes
[HDMI TC Out]	●	–	Yes	No	Yes	No	Yes
[Clip Name Format]	●	–	*2	No	Yes	No	Yes
[Update Media]	●	–	No	No	No	No	No
[Format Media]	●	–	No	No	No	No	No
[Media Life]	●	–	No	No	No	No	No

*1 [Setting] not applicable

*2 [Auto Naming] applicable, [Camera ID] not applicable

[Monitoring]

Item (level 2)	Camera menu	Web menu	All File	Scene File	All Reset (except for Network Settings)	Network Reset	Factory Default
[Output Format]	●	●	Yes	No	Yes	No	Yes
[Output Display]	–	●	Yes	No	Yes	No	Yes
[Display On/Off]	●	–	Yes	No	Yes	No	Yes
[Video Signal Monitor]	●	–	Yes	No	Yes	No	Yes
[Marker]	●	–	Yes	No	Yes	No	Yes

[Audio]

Item (level 2)	Camera menu	Web menu	All File	Scene File	All Reset (except for Network Settings)	Network Reset	Factory Default
[Audio Input]	●	▲	Yes	No	Yes	No	Yes
[Audio Output]	●	▲	Yes	No	Yes	No	Yes

[Thumbnail]

Item (level 2)	Camera menu	Web menu	All File	Scene File	All Reset (except for Network Settings)	Network Reset	Factory Default
[Display Clip Properties]	●	–	No	No	No	No	No
[Set Clip Flag]	●	–	No	No	No	No	No
[Lock/Unlock Clip]	●	–	No	No	No	No	No
[Delete Clip]	●	–	No	No	No	No	No
[Copy Clip]	●	–	No	No	No	No	No
[Transfer Clip]	●	–	No	No	No	No	No
[Transfer Clip (Proxy)]	●	–	No	No	No	No	No
[Filter Clips]	●	–	No	No	No	No	No
[Customize View]	●	–	Yes	No	Yes	No	Yes

[Technical]

Item (level 2)	Camera menu	Web menu	All File	Scene File	All Reset (except for Network Settings)	Network Reset	Factory Default
[Color Bars]	●	–	*1	No	*1	No	Yes
[Genlock]	●	–	No	No	No	No	No
[Tracking Data Output]	–	●	Yes	No	Yes	No	Yes
[Tally]	●	●	Yes	No	Yes	No	Yes
[Rec Review]	●	–	Yes	No	Yes	No	Yes
[Zoom]	●	–	Yes	No	Yes	No	Yes
[IR Remote]	–	●	No	No	Yes	No	Yes
[Lens]	●	–	Yes	No	Yes	No	Yes
[APR]	●	–	No	No	No	No	No

*1 [Type] applicable, [Setting] not applicable

[Network]

Item (level 2)	Camera menu	Web menu	All File	Scene File	All Reset (except for Network Settings)	Network Reset	Factory Default
[Camera Name]	–	•	No	No	No	No	Yes
[User]	–	•	No	No	No	Yes	Yes
[Wired LAN] ^{*1}	▲	•	No	No	No	Yes	No
[File Transfer]	•	▲	Yes	No	Yes	No	Yes
[FTP Server 1]	–	•	No	No	Yes	No	Yes
[FTP Server 2]	–	•	No	No	Yes	No	Yes
[FTP Server 3]	–	•	No	No	Yes	No	Yes
[SSL]	–	•	No	No	No	Yes	Yes
[SSH]	–	•	No	No	No	Yes	Yes
[Referer Check]	–	•	No	No	No	Yes	Yes
[Brute Force Attack Protection]	–	•	No	No	No	Yes	Yes

*1 Not configurable using the camera menu (display only)

[Stream]

Item (level 2)	Camera menu	Web menu	All File	Scene File	All Reset (except for Network Settings)	Network Reset	Factory Default
[Stream Setting]	–	•	No	No	Yes	No	Yes
[Video Stream]	–	•	Yes	No	Yes	No	Yes
[Audio Stream]	–	•	Yes	No	Yes	No	Yes

[Maintenance]

Settings screen (level 2)	Camera menu	Web menu	All File	Scene File	All Reset (except for Network Settings)	Network Reset	Factory Default
[Language]	•	•	Yes	No	Yes	No	Yes
[Clock Set]	•	•	Yes ^{*1}	No	Yes ^{*2}	No	Yes
[Reset]	–	•	No	No	No	No	No
[Hours Meter]	•	–	No	No	No	No	No
[Information]	–	•	No	No	No	No	No
[System Log]	–	•	No	No	No	No	Yes
[HTTP Access Log]	–	•	No	No	No	No	Yes

Settings screen (level 2)	Camera menu	Web menu	All File	Scene File	All Reset (except for Network Settings)	Network Reset	Factory Default
[Service]	–	•	No	No	No	No	No
[EULA]	–	•	No	No	No	No	No
[Software]	–	•	No	No	No	No	No

*1 Date and time information not applicable

*2 [Time Zone], date, and time information not applicable

PTZ AFR settings screen

Settings screen	Target function	All File	Scene File	All Reset (except for Network Settings)	Network Reset	Factory Default
[Initial Setup]	All	No	No	No	No	No
[Framing]	All	No	No	Yes	No	Yes
[Tracking Operation]	All	Yes	No	Yes	No	Yes
[Start Position]	Setting the start position	No	No	Yes	No	Yes
[Detection Settings]	All	Yes	No	Yes	No	Yes
[Others]	All	Yes	No	Yes	No	Yes

TP1001804719

Preset Position Saved Items

“Yes” indicates a setting that is saved for the preset position, and “No” indicates a setting that is not saved.

Pan/tilt items

Display location	Item	Save target
Framing control panel of live operation screen	Pan/tilt position	Yes
	[Pan-Tilt Speed]	No
[Pan-Tilt] in the web menu	[P/T Speed]	No
	[P/T Acceleration]	No
	[P/T Range Limit]	No
	[P/T Direction]	No
	[P/T Preset] – [Pan-Tilt Speed] – [Default Speed]	Yes ¹⁾

1) The values of settings when saving a preset position are saved as the values of that preset position. After values are saved, the values can be changed for each preset position. For details, see “Changing the Transition Speed (Pan-Tilt/Zoom/Focus) When Restoring a Preset Position.”

Zoom items

Display location	Item	Save target
Framing control panel of live operation screen	Zoom position (focus distance)	Yes
	[Zoom Speed]	No
[Pan-Tilt] – [P/T Preset] – [Default] in the web menu	[Zoom Speed]	Yes ¹⁾
[Technical] – [Zoom] in the camera menu	[Zoom Type]	No

1) The values of settings when saving a preset position are saved as the values of that preset position. After values are saved, the values can be changed for each preset position. For details, see “Changing the Transition Speed (Pan-Tilt/Zoom/Focus) When Restoring a Preset Position.”

Focus items

Display location	Item	Save target
Camera image panel of live operation screen	Tracking target specified for realtime tracking AF	No
	Specified coordinates for spot focus	No

Display location	Item	Save target
 (Focus) tab of live operation screen	[Touch Focus] switch	No
	[Auto Focus] switch	Yes
	[Focus Hold] button state	No
	[Push AF/MF] button state	No
	[Subject Recognition AF]	Yes
	[AF Subj. Shift Sens.]	Yes
	[AF Transition Speed]	Yes
	Focus position	Yes ¹⁾
[Shooting] – [Focus] in the web menu	[Touch Function in MF]	No
	[AF Assist Control]	No
[Pan-Tilt] – [P/T Preset] – [Default] in the web menu	[Focus Recall]	Yes ²⁾
	[MF Speed]	Yes ²⁾
[Shooting] – [Focus] in the camera menu	Focus area size and position set using [Focus Area]	Yes

1) Not restored when the [Auto Focus] switch is set to the on position. Restored when set to off.

2) The values of settings when saving a preset position are saved as the values of that preset position. After values are saved, the values can be changed for each preset position. For details, see “Changing the Transition Speed (Pan-Tilt/Zoom/Focus) When Restoring a Preset Position.”

Related Topic

- [Changing the Transition Speed \(Pan-Tilt/Zoom/Focus\) When Restoring a Preset Position](#)

TP1001804720

Block Diagrams

Audio Input

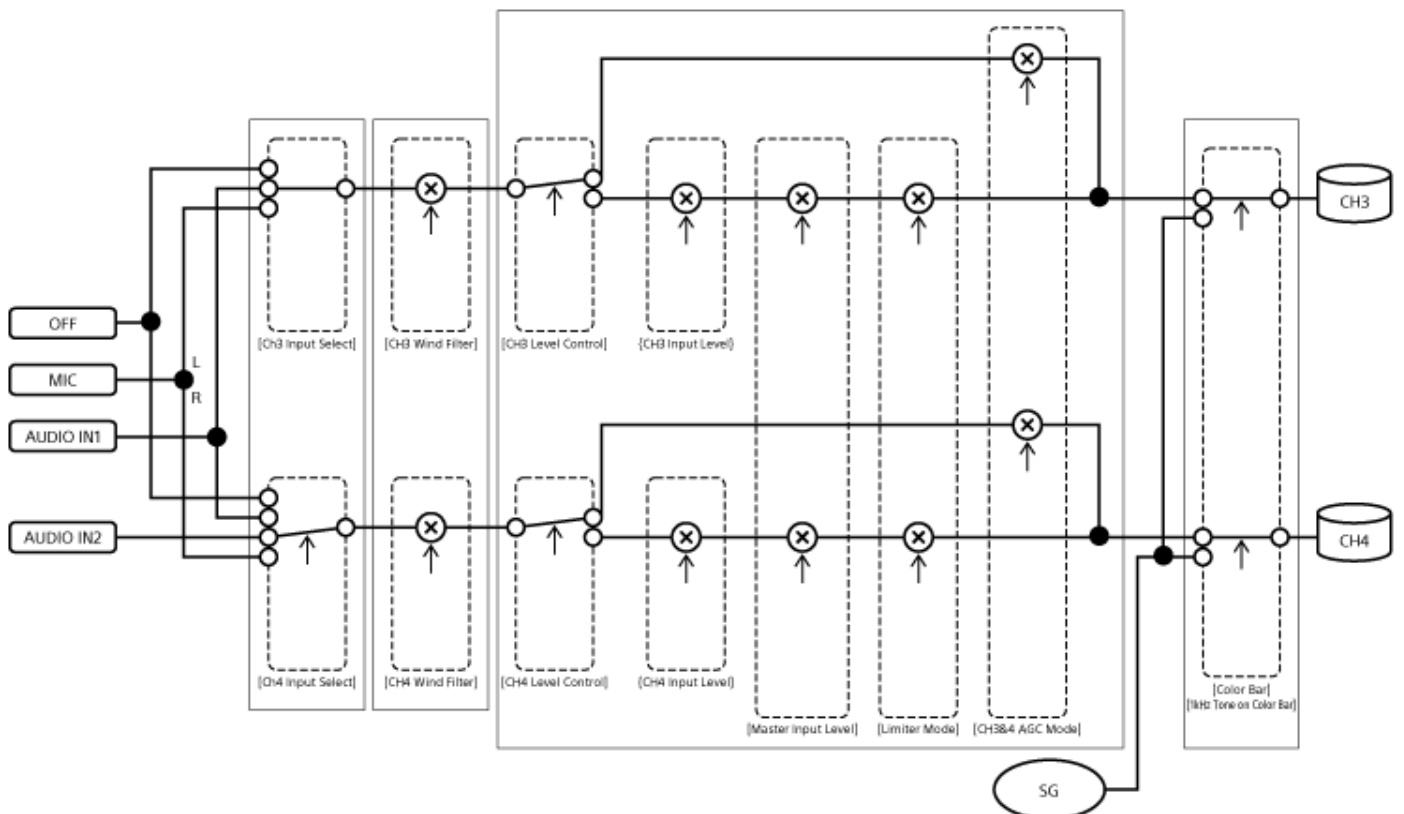
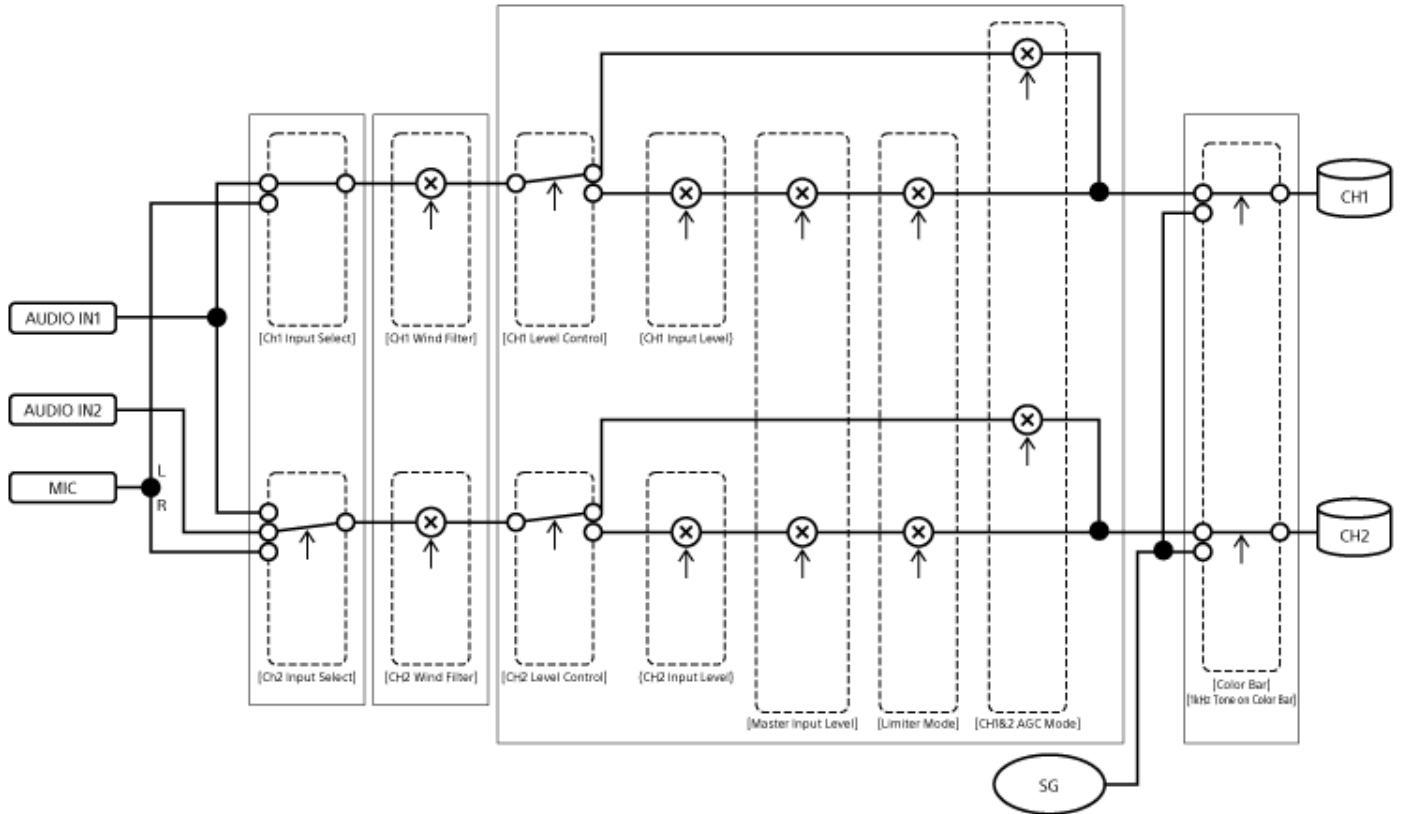

Audio Output

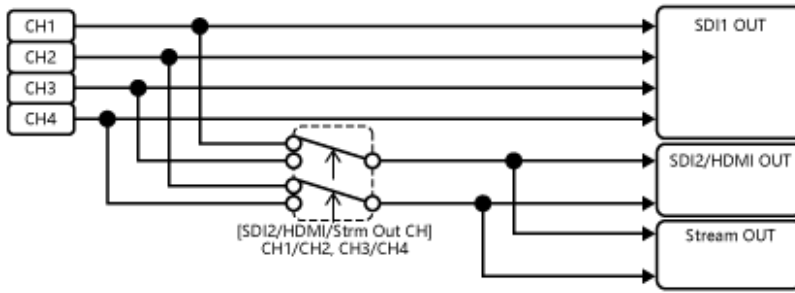

TP1001804721

5-065-326-11(1) Copyright 2024 Sony Corporation

Color Video Camera
BRC-AM7

Licenses

MPEG-4 AVC Patent Portfolio License

THIS PRODUCT IS LICENSED UNDER THE AVC PATENT PORTFOLIO LICENSE FOR THE PERSONAL USE OF A CONSUMER OR OTHER USES IN WHICH IT DOES NOT RECEIVE REMUNERATION TO

- (i) ENCODE VIDEO IN COMPLIANCE WITH THE AVC STANDARD (“AVC VIDEO”) AND/OR
- (ii) DECODE AVC VIDEO THAT WAS ENCODED BY A CONSUMER ENGAGED IN A PERSONAL ACTIVITY AND/OR WAS OBTAINED FROM A VIDEO PROVIDER LICENSED TO PROVIDE AVC VIDEO.

NO LICENSE IS GRANTED OR SHALL BE IMPLIED FOR ANY OTHER USE. ADDITIONAL INFORMATION MAY BE OBTAINED FROM MPEG LA, L.L.C. SEE [HTTP://WWW.MPEGLA.COM](http://www.mpegla.com)

Obtaining Software Under the GPL/LGPL License

This product uses software to which the GPL/LGPL applies. This informs you that you have a right to have access to, modify, and redistribute source code for these software programs under the conditions of the GPL/LGPL.

The source code is provided on the internet. Use the following URL and follow the download instructions.

<https://oss.sony.net/Products/Linux/>

We would prefer that you do not contact us about the contents of the source code.

μT-Kernel source code

This product uses the source code of μT-Kernel under T-License 2.1 granted of TRON Forum (www.tron.org).

TP1001804722

Color Video Camera
BRC-AM7

Specifications

General

Mass

- Approx. 3.5 kg (7 lb 11 oz)

Dimensions

See “External dimensions.”

Power requirements

- 12 V DC (XLR 4-pin)
- PoE++ (IEEE802.3bt, Type 4, Class 8 compliant)

Power consumption

- 132 W (max) with DC IN supply
- PoE++: 71.3 W (max)

Operating temperature

- 0 °C to 40 °C (32 °F to 104 °F)

Storage temperature

- –20 °C to +60 °C (–4 °F to +140 °F)

Recording format (video)

- XAVC HS Long 422/420
- XAVC S Long 422/420
- XAVC S-I Intra

Recording format (audio)

- LPCM 24-bit, 48 kHz, 4-channel

Recording frame rate

- XAVC HS Long 422/420
3840×2160/119.88P*, 100P*, 59.94P, 50P, 23.98P
 - XAVC S Long 422/420
3840×2160/119.88P*, 100P*, 59.94P, 50P, 29.97P, 25P, 23.98P
1920×1080/119.88P*, 100P*, 59.94P, 50P, 29.97P, 25P, 23.98P
 - XAVC S Intra
3840×2160/59.94P, 50P, 29.97P, 25P, 23.98P
1920×1080/59.94P, 50P, 29.97P, 25P, 23.98P
- * When Slow & Quick Motion is turned on, 119.88P and 100P cannot be used.

Recording/playback time

- XAVC HS Long 420
3840×2160/59.94P
Approx. 80 minutes (using CEA-G160T)
- XAVC S Long 420
3840×2160/59.94P

- Approx. 80 minutes (using CEA-G160T)
1920×1080/59.94P
- Approx. 270 minutes (using CEA-G160T)
- XAVC S Intra
3840×2160/59.94P
Approx. 25 minutes (using CEA-G160T)
1920×1080/59.94P
Approx. 75 minutes (using CEA-G160T)

Note

- The recording/playback time may vary due to usage conditions and memory characteristics. The recording and playback times are for a continuous recording as a single clip. The actual times may be shorter, depending on the number of clips recorded.

Pan/tilt drive section

- Pan drive range/speed: $\pm 175^\circ$, 0.004 °/sec to 180 °/sec
- Tilt drive range/speed: -30° to 210° , 0.004 °/sec to 180 °/sec
- Noise criterion rating: NC25 or lower
- Number of preset positions: 100
The number of available preset positions will vary depending on the remote that is used (web application: 100, RM-IP500: 100, supplied infrared remote control: 3)

Camera section

Imaging device

- 1.0 inch ExmorRS CMOS image sensor

Number of pixels

- Approx. 14 megapixels (total pixels)

Auto focus

- Detection method: Phase detection/contrast detection

Internal ND filters

- [Clear]: None
- 1: 1/4ND
- 2: 1/16ND
- 3: 1/64ND
- Linearly variable ND: 1/4ND to 1/128ND

Shutter speed

- 64 frames to 1/8000 sec (23.98P)

Shutter angle

- 5.6° to 360° , 2 to 64 frames

Slow & Quick Motion

- XAVC S QFHD: 1 fps to 120 fps
- XAVC S HD: 1 fps to 240 fps

White balance

- 2000 K to 15000 K

Gain

- -3 dB to $+36$ dB (1 dB increments)

Base look

- [S-Cinetone], [ITU709], [709tone], [s709], [709(800%)], [S-Log3], [HLG Live], [HLG Mild], [HLG Natural]

Lens section

- Zoom ratio: Optical 20×, Digital 30× (4K resolution) / 40× (Full HD resolution)
- Focal length: f = 24 mm to 480 mm (35 mm equivalent)
- F-number: F2.8 (wide) to F4.5 (telephoto)
- Horizontal angle of view: Approx. 75°
- Minimum shooting distance: 10 mm

Audio section

Sampling frequency

- 48 kHz

Quantization

- 24-bit

Frequency response

- XLR input MIC mode: 20 Hz to 20 kHz (± 3 dB or less)
- XLR input LINE mode: 20 Hz to 20 kHz (± 3 dB or less)

Dynamic range

- XLR input MIC mode: 80 dB (Typical)
- XLR input LINE mode: 90 dB (Typical)

Distortion

- XLR input MIC mode: 0.08% or lower (-40 dBu input level)
- XLR input LINE mode: 0.08% or lower ($+14$ dBu input level)

Input/output section

Inputs

DC IN connector

- XLR 4-pin, 11 to 17 V, 12 A (max)

AUDIO IN connector

- AUDIO IN 1 / AUDIO IN 2: XLR 3-pin \times 2, female
LINE / MIC / MIC+48V switchable
MIC: Reference -30 dBu to -80 dBu
- MIC: $\varnothing 3.5$ mm stereo mini jack, plug-in power compatible

GENLOCK IN connector

- BNC connector, 1.0 Vp-p, 75 Ω

TC IN connector

- BNC connector

Outputs

SDI OUT 1 (12G) connector / SDI OUT 2 connector

- SDI OUT 1 (12G): 12G-SDI output BNC type, 12G-SDI / 6G-SDI / 3G-SDI (Level A/B) / HD-SDI
- SDI OUT 2: 3G-SDI output BNC type, 3G-SDI (Level A) / HD-SDI

HDMI connector

- Type-A connector

OPTICAL output connector

- SFP+ compliant

* The same signal as the 12G-SDI output connector is output. The unit does not support optical signal input.

Input/output

LAN (network) connector

- RJ-45, 1000BASE-T

OPTION connector

- RJ-45 tally input/output connector

VISCA IN connector / VISCA OUT connector

- Control protocol: VISCA RS-422

Media slot section

- CFexpress Type A / SD card slot (2)

Supplied accessories

- Infrared remote control (1)
- QR code seal (1)
- Safety Regulations (2)
- Warranty booklet (1)
- Ceiling bracket (A) (1)
- Ceiling bracket (B) (1)
- Fall prevention wire rope (1)
- +PSW M3×8 screws (6)
- +PSW M4×8 stainless steel screw for fall prevention wire rope (1)

External dimensions

Dimensions are approximate values.

Unit: mm (inches)

Camera body

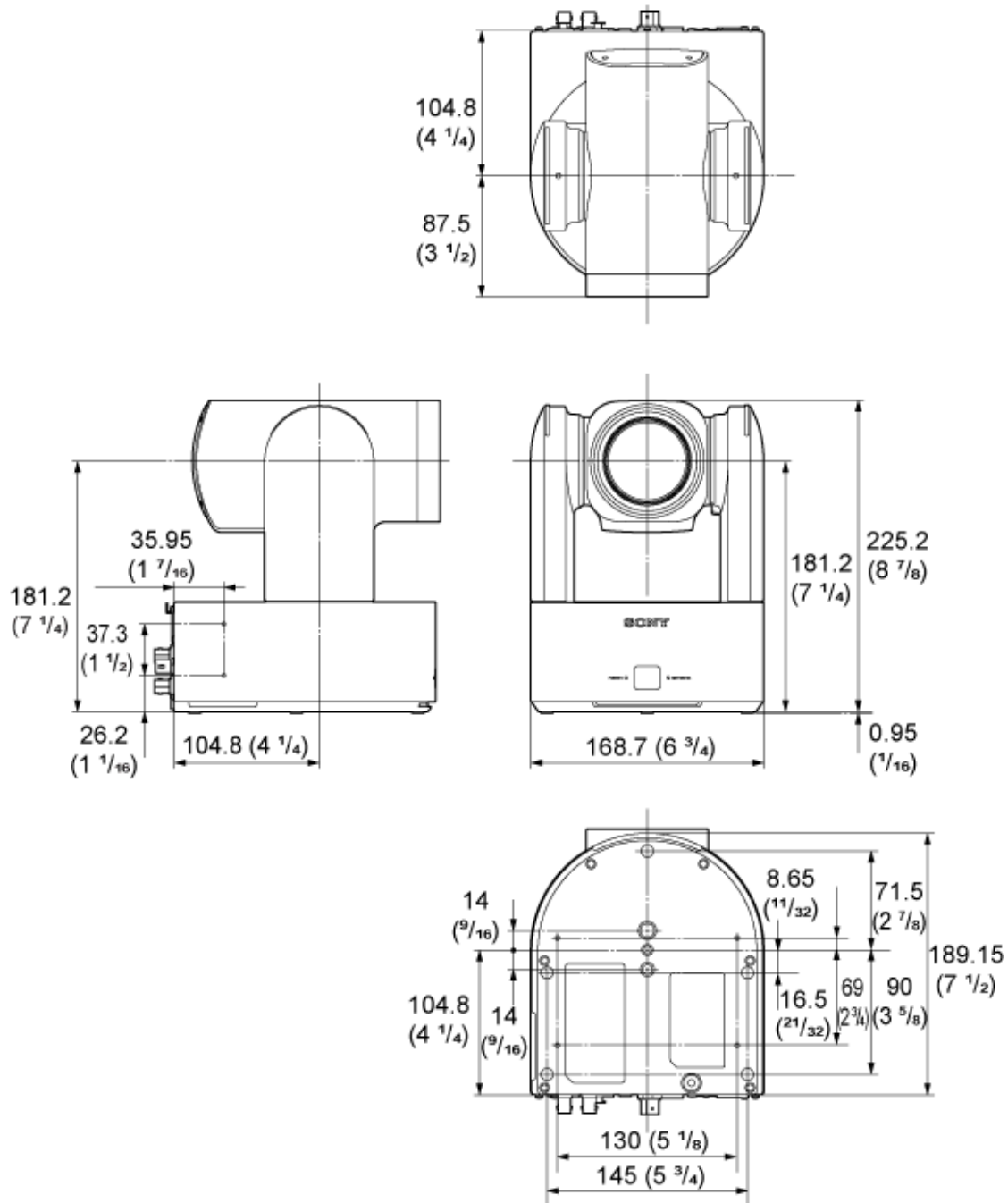

Ceiling bracket (B)

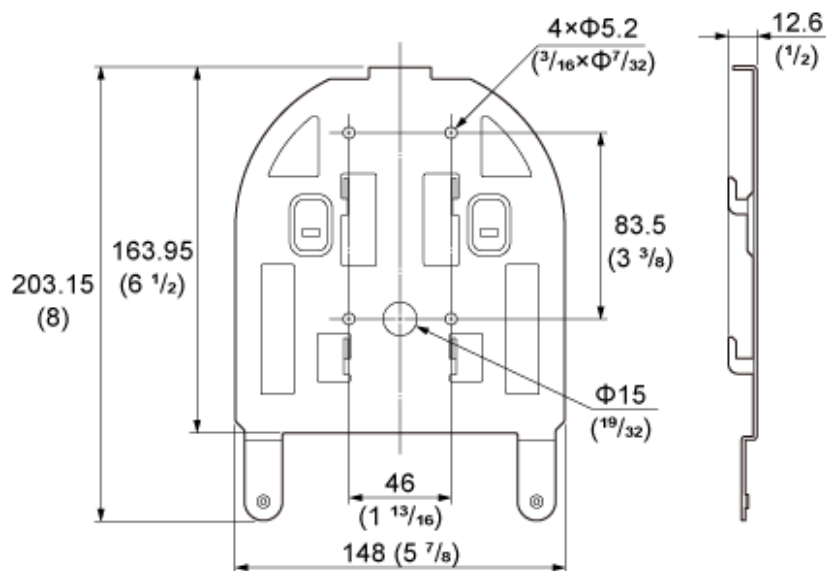

Design and specifications are subject to change without notice.

Trademarks

- XAVC and  are registered trademarks of Sony Group Corporation.
 - The terms  HDMI, HDMI High-Definition Multimedia Interface, HDMI Trade dress and the HDMI Logos are trademarks or registered trademarks of HDMI Licensing Administrator, Inc.
 - Microsoft and Windows are trademarks or registered trademarks of Microsoft Corporation in the United States and/or other countries.
 - Mac and macOS are registered trademarks of Apple Inc. in the U.S. and other countries.
 - The "Catalyst Browse" logo is a trademark or registered trademark of Sony Group Corporation.
 - IOS is a trademark or registered trademark of Cisco in the U.S. and other countries and is used under license.
 - iPadOS, Safari, and iPad are trademarks of Apple Inc., registered in the U.S. and other countries and regions.
 - Android and Google Chrome are trademarks or registered trademarks of Google LLC.
 - Wi-Fi is a registered trademark of Wi-Fi Alliance.
 - SDXC logo is a trademark of SD-3C, LLC.
 - CFexpress and the CFexpress Type A logo are trademarks of the CompactFlash Association.
 - NewTek™ and NDI® are trademarks or registered trademarks of NewTek, Inc.
 - JavaScript is a registered trademark or trademark of Oracle Corporation and/or its affiliates in the US and other countries.
 - Intel, the Intel logo, and Intel Core are trademarks of Intel Corporation or its subsidiaries.
 - QR Code is a trademark of Denso Wave Inc.
 - All other company names and product names are registered trademarks or trademarks of their respective owners.
- Trademarked items are not indicated by ™ or ® symbols in this document.

TP1001804725